

# AFP 2019

## EXHIBITOR SERVICE KIT

AFP 2019

BOSTON | OCTOBER 20-23

June 2019

Dear AFP Exhibitors and Sponsors,

The AFP Annual Conference is rapidly approaching and will be here before you know it. With about four months to go, it will be important to read this manual and meet all of the deadlines. Let's get started.

The AFP Exhibitor Service Kit includes the information you need to plan your participation for AFP 2019. It includes rules and regulations for participating in the conference, deadline schedules, registration information, exhibitor installation schedules, exhibit hall hours, conference schedules, marketing and sponsorship opportunities, how to order electric, carpeting, labor, catering and much more.

AFP and Freeman, the official General Service Contractor, will be working hard to help ensure AFP 2019 is a successful event for you.

Should you have any questions or need further assistance, please email us at [exhibiting@afponline.org](mailto:exhibiting@afponline.org). We look forward to working with you in the upcoming months.

Sincerely,  
The AFP Sales and Exhibits Team

[www.AFP2019.org](http://www.AFP2019.org)

4520 East-West Highway | Suite 800 | Bethesda, MD 20814 | USA | T: +1 301.907.2862

## TABLE OF CONTENTS

- **Conference Contact Information** ..... Page 5  
 AFP Sales and Client Services  
 Freeman - Official General Service Contractor  
 Boston Convention & Exhibition Center
- **Preferred Vendor Listing** ..... Page 7
- **Calendar of Deadlines** ..... Page 9  
 Association for Financial Professionals (AFP) ..... Pages 10-11  
 Preferred Vendors ..... Pages 10-11  
 Freeman ..... Pages 10-11
- **Exhibitor Guidelines & Restrictions** ..... Page 12  
 AFP Exhibitor Guidelines & Restrictions ..... Pages 13-17  
     Non-Registrant Conference Passes ..... Page 15  
     Installation & Dismantling Vendors ..... Page 15  
     Talent/Entertainment Vendors ..... Page 15  
 IAEE Exhibitor Guidelines & Restrictions ..... See Appendix
- **AFP Conference Information** ..... Page 18  
 Exhibitor Registration Policies and Guidelines ..... Pages 19-21  
 Exhibitor Conference Schedules ..... Pages 22-27  
     Exhibitor Installation and Dismantling  
     Exhibit Hall Hours  
     Official Conference Dates and Times  
     Exhibitor Event Hosting Time Restrictions  
     Conference Schedule  
 Current Exhibit Hall Floor Plan ..... Page 28  
 Current Exhibitor Listing ..... Pages 28-30  
 Housing and Conference Hotel Information ..... Pages 31-32  
 Media Coverage ..... Page 33
- **AFP Promotional Opportunities** ..... Page 34  
 Marketing & Sponsorship Opportunities ..... Page 35  
 Advertising Opportunities ..... Pages 36-38

## Appendix

- **AFP Order/Request Forms..... Page 39**
  - Sponsorship Brochure
  - Advertising Opportunities
    1. AFP Exchange Insertion Order Form
    2. AFP Inside Treasury Newsletter Insertion Order Form
    3. AFP Treasury & Finance Week Insertion Order Form
    4. FP&A In Focus Insertion Order Form
    5. Conference Advertising Order Form
  
- **Preferred Vendor Order Forms/Brochures.....Page 40**
  - a. Event Planning (CSI DMC)
  - b. Event Shuttle Boarding Request (Kushner Shuttles)
  - c. Floral Service (National Plant & Floral, Inc.)
  - d. Lead Retrieval (Expo Logic)
  - e. Photography (Convention Photo by Joe Orlando)
  - f. Catering (Levy Restaurants)
  - g. Internet/Network/Telephone Service (Boston Convention & Exhibition Center)
  - h. Security (Boston Convention & Exhibition Center)
  
- **Freeman General Information ..... Page 41**
  - Freeman Quick Facts
    - Green Tips for Exhibitors
  
- **Freeman Payment Information ..... Page 42**
  1. Method of Payment
    - Third-Party Authorization
    - Freeman Terms & Conditions
      - Payment & Labor**
      - Material Handling**
  
- **Freeman Services & Order Forms ..... Page 43**
  - Audio Visual
  - Accessories Order Forms
  - Air/Water/Drain/Gas Order Form
    - Artwork Guidelines
  - Booth Set-Up & Dismantle Information
  - Cleaning Order Form
  - Cut to Size Carpet Order Form
  - Electrical and Power Order Forms
  - Electrical Exhibiting Information
  - Exhibitor Bill of Rights

- Fabric Graphics Order Form
- Forklift/Rigging Labor Order Form
- Furnishing Order Forms
- Graphics Order Form
- Hanging Sign Order Form
  - Hanging Sign Procedure and Rules
  - Hanging Truss & Chain Hoist Order Forms
  - Inbound Freight Procedures
  - Installation and Dismantle Labor Order Form
  - Marshalling Yard Map
  - Material Handling Order Form
  - Rental Exhibits Order Form
  - Shipping Label - Hanging Sign
  - Shipping - Outbound
  - Shipping Label – Show Site
  - Shipping Label – Warehouse
  - Showcase Order Form
  - Smart Fabric Order Form
  - Standard Size Freeman Carpet Order Form
  - Structural Integrity Statement
  - Total Flex Order Form
  - Transportation Order Form
  - Truck Scale Locations
- **IAEE Guidelines & Restrictions..... Page 44**

## **SECTION I**

### **CONFERENCE CONTACT INFORMATION**

## CONFERENCE CONTACT INFORMATION

### AFP Sales

4520 East West Highway, Suite 800  
Bethesda, MD 20814  
Phone: 301.961.8861  
Website: [www.afponline.org](http://www.afponline.org)

#### Kevin Boyle

Director of Access Sales  
Phone: 301.961.8861  
E-mail: [kboyle@afponline.org](mailto:kboyle@afponline.org)

#### Tim Momyer

Access Sales Account Executive  
Phone: 301.961.8838  
E-mail: [tmomyer@afponline.org](mailto:tmomyer@afponline.org)

#### David Pim

Access Sales Account Executive  
Phone: 301.961.8891  
E-mail: [dpim@afponline.org](mailto:dpim@afponline.org)

### Official General Service Contractor

#### Freeman

275 Bodwell Street  
Avon, MA 02322  
Phone: (508) 894-5100 • Fax: (469) 621-5608  
Email: [FreemanBostonES@freemanco.com](mailto:FreemanBostonES@freemanco.com)  
Website: [www.freemanco.com](http://www.freemanco.com)

### Convention Center

#### Boston Convention and Exhibition Center

415 Summer Street  
Boston, MA 02210  
Phone: 617.954.2000  
Website: <https://www.signatureboston.com/Exhibit>

## **SECTION II**

### **PREFERRED VENDOR LISTING**



## PREFERRED VENDORS

To place an order, see the Appendix for order forms.

### CATERING SERVICE

#### Levy Restaurants

##### Boston Convention & Exhibition Center

Contact: Eiman Karim  
Phone: 617.954.2320  
Email: [ekarim@levyrestaurants.com](mailto:ekarim@levyrestaurants.com)

### CUSTOM BOOTHS

#### Freeman

Contact: Philip Darbouze  
Phone: 1.702.579.1438 (O) / 1.702.635.1125 (M)  
Email: [philip.darbouze@freemanco.com](mailto:philip.darbouze@freemanco.com)

### EVENT PLANNING

#### CSI DMC

Contact: Carrie Heiden  
Phone: 703.584.2494 (O)/202.412.3490 (M)  
Email: [carrie.heiden@csi-dmc.com](mailto:carrie.heiden@csi-dmc.com)  
Website: [www.csi-dmc.com](http://www.csi-dmc.com)

### FLORAL SERVICE

#### National Plant & Floral, Inc.

Phone: 702.956.8011  
E-mail: [exhibitorservice@nationalplantfloral.com](mailto:exhibitorservice@nationalplantfloral.com)

### HOUSING

#### AFP Housing Customer Contact Center

Monday - Friday, 9am - 9pm (Eastern Time)  
800.618.4242 (Toll Free U.S. & Canada)  
415.979.2269 (Outside U.S. & Canada)  
Link to Email Support: <https://afp.cmrushelp.com/>

### INTERNET/NETWORK/TELEPHONE SERVICE

#### Boston Convention & Exhibition Center

Phone: 617.954.2230  
Email: [exhibitorservices@signatureboston.com](mailto:exhibitorservices@signatureboston.com)

### LEAD RETRIEVAL

#### EXPO LOGIC

Phone: 1.888.249.0367 or 1.484.751.5131  
Email: [expologic-myexpoleads@communitybrands.com](mailto:expologic-myexpoleads@communitybrands.com)  
Website: <https://myexpoleads.expologic.com/index.cfm/order/showCode/AFP2019/>

### PHOTOGRAPHY

#### Convention Photo by Joe Orlando, Inc.

Phone: 1.626.639.3015  
Fax: 1.626.794.0525  
Email: [mail@joeorlandophoto.com](mailto:mail@joeorlandophoto.com)  
Website: [www.joedorlandophoto.com](http://www.joedorlandophoto.com)

### SECURITY

#### Boston Convention & Exhibition Center

Phone: 617.954.2230  
Email: [exhibitorservices@signatureboston.com](mailto:exhibitorservices@signatureboston.com)

### SHIPPING SERVICES

#### Freeman

Phone: 1.800.995.3579  
E-Mail: [exhibit.transportation@freemanco.com](mailto:exhibit.transportation@freemanco.com)

### TEMP STAFFING

#### JOHNLEONARD Staffing

E-Mail: [info@johnleonard.com](mailto:info@johnleonard.com)  
Website: <https://www.johnleonard.com/>

### TRANSPORTATION

#### Kushner & Associates

Contact: Kirsten Young  
Email: [k.young@kushnershuttles.com](mailto:k.young@kushnershuttles.com)  
Website: <http://www.kushnershuttles.com/>

## **SECTION III**

### **CALENDAR OF DEADLINES**

## **DEADLINE CALENDAR**

*To receive the best marketing exposure for your company, the following items should be reserved as soon as possible.*

### **ASAP**

- I. Website Advertising ..... ASAP
- II. White Papers Advertising ..... ASAP

### **JUNE**

- Company listing/logo/service categories for Mobile App ..... Jun 28

### **JULY**

- Sponsorship Packages ([click here](#) to view sponsorships) ..... July 13

### **AUGUST**

- AFP Housing Rooming List ..... Aug 23

### **SEPTEMBER**

#### **Preferred Vendor Discount Deadline**

- Lead Retrieval (Expo Logic Discount)..... Aug 29
- Catering Service (Levy Restaurants)..... Sept 27
- Electrical Order Discounted Rate ..... Sept 27
- Telephone Services Discounted Rate ..... Sept 27
- Internet & Technical Services Discounted Rate ..... Sept 27
- Rigging Services Discounted Rate ..... Sept 27
- Security Services Discounted Rate ..... Sept 27
- FREEMAN Order Forms – Discount Deadline ..... Sept 27

#### **Due to AFP**

- Exhibit Hall Carpet Decal Advertising..... Jul 19
- Company Message Banner in Food Court ..... Aug 16
- AFP Exchange – Fall Issue (Bonus AFP 2019 Distribution) ..... Aug 30
- Advertising Opportunities..... Sept 7
- Submit customized booth designs for approval (20x20 booths and up)..... Sept 9
- Discounted exhibitor registration deadline ..... Sept 20

## **OCTOBER**

### **Due to AFP**

- Registration Bag Insert Request.....Aug 1
- Conference Daily News advertising.....Aug 26
- Registration Bag Insert Materials .....Aug 30
- Educational Session Evaluations (by track).....Aug 30
- Non-Registrant Conference Pass Forms.....Oct 4

### **PREFERRED VENDORS DEADLINES\***

- Last Day to Request Housing Room Block .....Aug 23
- Event Planning (CSI-DMC).....Oct 4
- Floral Order Form (National Plant & Floral, Inc.) ..... Oct 12
- Internet/Network/Telephone Service ( ) ..... Oct 17
- Photography Service (Convention Photo by Joe Orlando) ..... Oct 17

*\*The preferred vendors listed above have been approved to participate in AFP 2019. Each of these vendors (with the exception of CSI-DMC) will have a representative stationed in the Exhibitor Service areas throughout the conference to assist you. Please note: If you choose to use other service vendors, you assume all risks. These vendors will accept requests after the suggested deadline. However, we encourage exhibitors to submit orders by this date to avoid any delays.*

## **SECTION IV**

### **AFP EXHIBITOR GUIDELINES AND RESTRICTIONS**

## AFP EXHIBITOR GUIDELINES AND RESTRICTIONS

### ❑ EXHIBIT LOCATION

All exhibits shall be located in Hall A/B of the Boston Convention & Exhibition Center, 415 Summer St, Boston, MA 02210. The attendee meals shall be located in Hall B as well.

### ❑ FUNCTIONS AND RECEPTIONS

Exhibitors shall not host events during official conference hours that are outside of the convention center licensed by AFP and hotels reserved by AFP in connection with the conference, including hospitality suites and function space.

Page | 13

#### OFFICIAL CONFERENCE HOURS (local time)

Sun, October 20, 2019	7:00 AM – 9:30 PM
Mon, October 21, 2019	8:00 AM – 6:00 PM – Exhibitor Events may start at 6:15 PM
Tue, October 22, 2019	8:30 AM – 5:30 PM – Exhibitor Events may start at 5:45 PM
Wed, October 23, 2019	8:30 AM – 11:00 AM

*Note: Conference Hours are subject to change at the sole discretion of AFP.*

### ❑ EXHIBIT HALL RULES

No one under the age of 21 is permitted to attend any conference function or is permitted in the exhibit hall at any time.

#### EXHIBIT HALL HOURS (local time)

Sun, October 20, 2019	6:00 PM – 7:30 PM
Mon, October 21, 2019	8:30 AM – 5:00 PM
Tue, October 22, 2019	8:30 AM – 5:30 PM

All booth displays shall be governed by and adhered to by the policies of the International Association of Exhibitions and Events (IAEE). **AFP limits all island booth spaces to a maximum height of 24 feet, no exceptions.** All other booth space configurations shall follow the IAEE guidelines accordingly.

AFP reserves the right to alter the exhibit hall floor plan to ensure continuity of the display area.

❑ **PROHIBITED CONDUCT**

- Exhibitors/Sponsors (or any conference attendee) are prohibited to utilize area other than their assigned exhibit space, at any AFP conference site. Prohibited conduct includes, but is not limited to, marketing, sales, distribution of promotional materials or any other activities conducted outside of your assigned exhibit space. This includes selling in the aisles or at any other event relating to AFP 2019.
- Except for official AFP activities, no exchange of monies consisting of, but not limited to, cash, credit cards, checks, or signing of purchase orders or contracts is allowed within the confines of the exhibit hall during the conference.
- Booth substitutions are not accepted for exhibiting companies except when there has been a merger or acquisition.
- AFP does not permit exhibitors to use balloons anywhere in the exhibit hall.
- No nails or bracing wires used in erecting displays may be attached to the building without written consent of the Director of Engineering at the convention center and AFP. All property destroyed or damaged by exhibitors must be replaced in its original condition by the exhibitor or at the exhibitor's expense.
- The logo for the Association for Financial Professionals is trademarked and cannot be used by any exhibitor in any manner (including on a booth or in promotional materials) for AFP 2019 without the express written permission of AFP.
- Except for signage within the approved limits of an exhibit space, signs are not allowed in any of the conference facilities (convention center or hotels) unless approved in advance by AFP 2019 management.

❑ **EXHIBIT BOOTH EQUIPMENT**

- Standard Booths  
Standard booth spaces shall be draped in a black 8' high backdrop and 36" high side rails. Exhibitor shall also receive a 7" x 44" exhibitor identification sign as part of a standard booth. AFP does not allow the drape color to be replaced with any other color.
- Carpet  
AFP shall provide the aisle carpet in tuxedo (black/grey). Each exhibitor is required to have carpeting in their area. Carpeting may be supplied by the exhibitor or rented from Freeman.

- Hanging Signs  
Only island booths are allowed hanging signage, with a height restriction of 24ft from the top of the sign to the floor.

**❑ CUSTOMIZED BOOTHS**

Any exhibitor with a custom booth design must email their booth drawings to [exhibiting@afponline.org](mailto:exhibiting@afponline.org) for approval by September 9, 2019. Depending on the design, the exhibitor may be asked to provide other documents.

**❑ INSTALLATION AND DISMANTLING (I&D) COMPANIES**

Exhibitors must submit an online [Non-Registrant Conference Pass Form](#) and Certificate of Insurance (COI) for any I&D company needing access to their exhibit booth. All forms must be submitted by October 4, 2019.

The COI should include the following within the “Description of Operations” section: conference name, exhibitor name/booth number, dates that your I&D company will need access to the booth, and the Association for Financial Professionals, Freeman, and Boston Convention & Exhibition Center listed as “Additional Insured”. See example.

**COI Example:**

**AFP 2019 (October 20-23, 2019)**

**Booth #:**

**Exhibitor Name:**

**Additional Insured: Association for Financial Professionals, Freeman, Boston Convention & Exhibition Center**

**❑ TALENT/ENTERTAINMENT VENDORS**

A [Non-Registrant Conference Pass Form](#) must be submitted online for any third party talent or entertainment vendors. See rules listed below. All forms must be submitted by October 4, 2019.

- I. Individual(s) may not be an employee of Exhibitor’s company and shall be there only to entertain attendees visiting your exhibit booth at conference.
- II. These individuals cannot have any sales interaction with conference attendees while in the exhibit hall and shall be uniquely identified.
- III. Each exhibitor is limited to (3) talent/entertainment vendors.

**❑ FOOD AND BEVERAGE IN YOUR BOOTH (CATERING SERVICES)**

Levy Restaurants is the exclusive catering service within the convention center. Any food or beverage dispensed or given away at booths or functions must be purchased from Levy catering; this includes bottled water, popcorn, cookies, etc. Exhibitors may receive an additional charge for any outside food or beverage vendors. Please contact Levy Restaurants directly regarding any third party vendors.

**Levy Restaurants**

Contact: Eiman Karim, Catering Sales Manager  
Phone: 617.954.2320  
Email: [ekarim@levyrestaurants.com](mailto:ekarim@levyrestaurants.com)

**❑ NON-FLAMMABLE MATERIALS**

All materials used in the exhibit hall, ballrooms or any other room of the convention center, must be non-flammable and conform to the fire regulations of the convention center. Electrical wiring and equipment installation must conform to the applicable regulations of the convention center. Materials not conforming to such regulations shall be removed immediately at the exhibitor's expense. It is strictly against fire codes to block or lock any fire exits.

**❑ STORAGE**

The convention center, hotels and AFP have no facilities for the storage of exhibits. All shipments for an exhibit must be directed to the official general contractor. Shipments that arrive prior to show time shall be directed to the local general contractor's warehouse for storage and shall be delivered, at the exhibitor's expense, to the exhibitor's booth at show time. Exhibitors may only store in their exhibit space a one day supply of distribution materials (brochures, etc.). Exhibitors requiring accessible storage on site must make arrangements prior to the conference with the general contractor. Show management may remove, at the exhibitor's expense, any materials that are improperly stored in or adjacent to an exhibit.

**❑ DISCARDED EXHIBIT MATERIALS**

Any exhibitors who discard their displays or any type of "bulk" material not considered normal refuse must make arrangements for its removal at their own expense. If the convention center and/or hotels have to remove these materials, the exhibitor shall be charged directly.

**❑ SECURITY PROVISIONS**

- a. AFP shall provide perimeter security service and exercise reasonable care for exhibitor's displays, equipment and materials. Uniformed security guards shall patrol the exhibit areas at the convention center during the period of installation, during the show and during dismantling.

- b. Provisions have been made for the convention center to check the locks on all doors, consistent with fire regulations, to minimize any problems when the show is closed. The security guards shall patrol the entire exhibit hall area and call to the attention of AFP any and all infractions of rules or potential security risk.
- c. The convention center has been requested to provide all their employees with identification badges or uniforms to avoid allowing any persons other than the night clean-up crews into the exhibit area when the show is closed. All drayage and decorating personnel shall be identified. In each case, this has been discussed with service management so that we may avoid any unauthorized personnel in the area during installation, during the show and during dismantling. All exhibitors and attendees are required to wear their official conference badges at all times. Anyone without proper ID shall be refused admittance into the exhibit hall. This security check is for your protection.
- d. Exhibitors agree that the provision of such security service constitutes adequate discharge of all obligations of AFP to supervise and protect exhibitor's property within the exposition. Exhibitors have the option to hire booth security to protect their exhibits, using the official security agency for the conference.
- e. Exhibitors are reminded that this is an open booth show and that the primary responsibility for the safeguard of the exhibit and equipment rests with the exhibitor. Neither the AFP, the convention center, the security contractor, the general contractor, nor any of their officers, agents, representatives or employees assumes any responsibility for such property at any time.

**❑ ADDITIONAL BOOTH SECURITY**

Exhibitors desiring the added protection of a booth guard for their exhibit during all or part of the conference may do so from the preferred security agency. Contact Signature Boston's exhibitor services at 617.954.2230 or email - [exhibitorservices@signatureboston.com](mailto:exhibitorservices@signatureboston.com)

## **SECTION V**

### **AFP CONFERENCE INFORMATION**

## EXHIBITOR REGISTRATION POLICIES & GUIDELINES

All attendees will be required to present a photo ID to pick up their AFP conference badge and registration materials. Badges will not be mailed out in advance and will be available on-site only. Switching and transferring badges is a violation of your contract with AFP and will subject the badge to confiscation. Please advise your personnel accordingly to avoid problems during the conference.

This section explains the different types of registrations made available to exhibiting companies and how AFP calculates the number of complimentary registrations your company receives. For security purposes, your complimentary registrations are for use by your staff only.

### HOW MANY COMPLIMENTARY BADGES COME WITH MY BOOTH SPACE?

Your complimentary Exhibitor Conference registrations are based on the size of your booth space. For example:

<u>Booth Size</u>	<u>You Get</u>	<u>Booth Size</u>	<u>You Get</u>
10x10	2	20x20	8
10x20	4	20x30	12
10x30	6	20x40	16
30x30	18	20x50	20
30x40	24		
		<u>Turnkey Booths</u>	<u>You Get</u>
		10x10	2
		10x20	4
		MindShift Pod	2

Booth spaces larger than 20x20 will receive one (1) complimentary Exhibitor Floor Pass. To purchase a turnkey booth, contact [AFP Sales](#).

### TYPES OF REGISTRATIONS

#### EXHIBITOR CONFERENCE REGISTRATIONS

Exhibitors receive two complimentary exhibitor conference registrations for each 100 square feet of booth space. These passes grant full access to the entire conference, including educational sessions and general sessions.

Exhibitors and sponsors can purchase additional exhibitor conference registrations for \$1,275 each

in our online exhibitor portal through September 20, 2019. After that date, these passes will cost \$1,799. This represents a steep discount over the standard conference pricing. The [online exhibitor portal](#) allows you to purchase the registrations with a credit card, assign your staff to those registrations, and make substitutions. These registrations are non-refundable.

### **EXHIBITOR FLOOR PASSES**

AFP offers exhibitor floor passes to accommodate your needs for additional staff to work in your booth. This registration includes access to the exhibit hall, the Sunday Night Kick-Off Party, breakfasts and lunches. It does not include access to the general sessions or the educational sessions. You may purchase up to 4 exhibit staff registrations per 100 square feet of booth space reserved. Exhibitor floor passes cost \$1,150 each and can be purchased through the exhibitor portal. These registrations are non-refundable.

### **SPEAKER**

An individual who has been selected by AFP to make a presentation or participate on a panel at the conference for a concurrent session, general session, roundtable, or workshop will be granted a speaker registration. For questions relating to speakers and their registrations, contact:

Marcia Solomon  
301.961.8858  
[msolomon@afponline.org](mailto:msolomon@afponline.org)

John Gibson  
301.961.8826  
[jgibson@AFPonline.org](mailto:jgibson@AFPonline.org)

### **SPOUSE/PARTNER BADGES**

A full conference registered attendee has the opportunity to purchase a spouse/partner pass at an additional charge of \$250 with your full conference registration (spouse/partner badges are not available through the exhibitor services portal). A spouse/partner cannot be a practicing treasury professional or a seller/provider of treasury management services. Spouse/partner attendance includes the exhibit hall (including breakfast and lunch), the general session, and the Sunday Night Kick-Off Party. It does not include any educational sessions.

### **OTHER ASSOCIATED FEES**

**LOST BADGE FEES:** If you lose your badge there is a \$50 replacement fee.

**SUBSTITUTIONS:** You can substitute your booth registrations at no charge in AFP's exhibitor portal. Once a badge is picked up onsite, it cannot be substituted.

### **CANCELLATIONS & REFUNDS**

**AFP will not grant refunds for any booth cancellations postmarked after May 31, 2019.**

For cancellations and refund requests postmarked prior to that date, exhibitors will owe 50% of

their original invoiced total. Exhibitors who have paid in full will receive a 50% refund for cancellations postmarked before May 31, 2019. AFP does not issue refunds for unused complimentary exhibitor registrations. No exceptions will be made.

**UNREDEEMED EXHIBITOR CONFERENCE REGISTRATIONS:** No refunds are issued.

## **REGISTRATION FAQ'S**

### **HOW DO I ASSIGN MY COMPLIMENTARY REGISTRATIONS THAT COME WITH THE BOOTH?**

You can assign the complimentary registration passes that come with the booth, track, and purchase additional registrations (NON-REFUNDABLE) through AFP's [online exhibitor portal](#). The primary booth contact at each company has been issued instructions on how to access the online exhibitor portal and manage registrations online. Only the designated primary booth/exhibitor contact has access to the online exhibitor portal. Please contact AFP at [exhibiting@afponline.org](mailto:exhibiting@afponline.org) if you need to change your primary booth/exhibitor contact. Include full business contact information and copy the current primary booth contact on that request.

Page | 21

### **WHEN IS THE DEADLINE TO ASSIGN THE REGISTRATION PASSES THROUGH THE ONLINE EXHIBITOR PORTAL?**

They need to be assigned no later than September 20 to be considered pre-registered and to be included in the attendee list.

### **WHAT IF I NEED MORE REGISTRATIONS THAN MY COMPLIMENTARY ALLOTMENT ALLOWS?**

If you need additional registrations, you can purchase Exhibitor Conference Registrations and Exhibitor Floor Passes through the online portal. These purchases are non-refundable..

If you have any questions regarding the number of complimentary registrations you receive or need further clarification on the types of registrations offered, contact [exhibiting@afponline.org](mailto:exhibiting@afponline.org).

## EXHIBITOR CONFERENCE SCHEDULE

### INSTALLATION HOURS:

Friday, October 18 .....	8:00 AM – 5:00 PM
Saturday, October 19 .....	8:00 AM – 5:00 PM
Sunday, October 20 .....	8:00 AM – 2:00 PM

**All booths must be installed no later than 2:00pm on SUNDAY.** AFP and Freeman need time to prepare the exhibit hall for the grand opening. Be sure that your staff arrive in town early enough to meet this deadline. **We encourage exhibitors to check in with AFP by 10:00am on Sunday to ensure the installation deadline is met.**

Page | 22

### DISMANTLING HOURS:

Tuesday, October 22 .....	5:30 PM – 11:59 PM
Wednesday, October 23.....	8:00 AM – 5:00 PM

**All exhibitor booths must be cleared no later than 5:00 PM on Wednesday, October 23.**

**All carriers (trucking companies) must check in no later than 2:00 PM on Wednesday, October 23 for freight pickup.**

### EXHIBIT HALL HOURS

AFP requires that your booth be staffed during the exhibiting hours listed below. Exhibitors may gain access to the exhibit hall **one (1) hour** prior to the published Conference hours each day. Exhibit Hall schedule is subject to change.

Sunday, October 20.....	6:00 PM – 7:30 PM
Monday, October 21 .....	8:30 AM – 5:00 PM
Tuesday, October 22 .....	8:30 AM – 5:30 PM
Wednesday, October 23 .....	NO EXHIBIT HOURS

#### NON-COMPETE EVENTS

**Exhibitors and Sponsors may not host events (including, without limitation, product demonstrations, client meetings, and user groups) outside the designated space that conflict with official conference hours.** Companies who do not either exhibit or sponsor are not allowed to host any events or reserve/rent space in any conference facility during the conference. Exhibitors violating this policy will lose all priority points — thereby jeopardizing their future participation in AFP Conferences.

Sunday, October 20	7:00 AM – 9:30 PM
Monday, October 21	8:00 AM – 6:00 PM (Events may start at 6:15 p.m.)
Tuesday, October 22	8:30 AM – 5:30 PM (Events may start at 5:45 p.m.)
Wednesday, October 23	8:30 AM – 11:00 AM

AFP will have space available at the Boston Convention and Exhibition Center as well as the Westin Boston Waterfront for exhibitors/sponsors to host product demonstrations, client meetings, and/or user groups. Exhibitors/Sponsors wishing to use such designated space should contact the [AFP Sales Team](#).

Exhibitors planning special events must make arrangements to meet any conference attendees outside the convention center. Inside the convention center, exhibitors may not use signs, placards or any other method to gather conference attendees.

## AFP CONFERENCE SCHEDULE

Listed below is the preliminary conference schedule for AFP 2019 as of June 14, 2019. This schedule is subject to change. **The most accurate schedule can be viewed at:**  
<https://conference.afponline.org/program/overview/schedule>

Exhibitors/Sponsors may not host events (including, without limitation, product demonstrations, client meetings, receptions and user groups) outside the designated space approved by AFP that conflict with official conference hours listed below.

### OFFICIAL CONFERENCE HOURS

Sunday, October 20	7:00 AM – 9:30 PM
Monday, October 21	8:00 AM – 6:00 PM
Tuesday, October 22	8:30 AM – 5:30 PM
Wednesday, October 23	8:30 AM – 11:00 AM

### Saturday, October 19

8:00 a.m. – 5:00 p.m.	Registration @ BCEC
10:00 a.m. – 5:00 p.m.	Satellite Registration @ Boston Park Plaza Hotel
8:30 a.m. – 4:30 p.m.	CTP Exam Review Course – Day 1 of 3
8:30 a.m. – 4:30 p.m.	Pre-Conference Workshops
1:00 p.m. – 5:00 p.m.	AFP Executive Institute Lounge– Sponsored by PNC
1:00 p.m. – 4:00 p.m.	Speaker Ready Room

### Sunday, October 20

7:30 a.m. – 6:30 p.m.	Registration @ BCEC
7:30 a.m. – 4:00 p.m.	Satellite Registration @ Boston Park Plaza Hotel
8:00 a.m. – 8:30 a.m.	Annual Meeting
8:00 a.m. – 3:30 p.m.	Pre-Conference Workshops
8:00 a.m. – 4:00 p.m.	Speaker Ready Room
8:00 a.m. – 4:00 p.m.	AFP Executive Institute Lounge- Sponsored by PNC
8:30 a.m. – 3:30 p.m.	CTP Exam Review Course – Day 2 of 3
8:30 a.m. – 12:30 p.m.	AFP Aware Community Service Day – Sponsored by BBVA Compass
8:30 a.m. – 9:00 a.m.	AFP Aware Registration and Breakfast
9:00 a.m. – 11:00 a.m.	AFP Aware Onsite Event – Pine Street Inn
9:00 a.m. – 11:30 a.m.	AFP Aware Offsite Event – Love Your Block
11:00 a.m. – 12:30 p.m.	AFP Aware Volunteer Lunch

12:45 p.m. – 1:15 p.m.	Executive Coaching – Sponsored by RTP
1:00 p.m. - 5:00 p.m.	AFP Aware Puppy Park
1:30 p.m. – 3:00 p.m.	FP&A Symposium
1:30 p.m. – 3:00 p.m.	Payments Symposium
1:30 p.m. - 3:00 p.m.	Executive Roundtable – Sponsored by RTP
3:00 p.m. – 4:00 p.m.	AFP Executive Reception–Sponsored by Chatham Financial
4:00 p.m. – 4:30 p.m.	Opening Keynote Doors Open
4:30 p.m. – 6:00 p.m.	Opening Keynote Session
6:00 p.m. – 7:30 p.m.	Exhibit Hall Grand Opening Reception
6:00 p.m. – 7:30 p.m.	AFP Canadian Reception sponsored by Citi Canada
6:00 p.m. – 7:30 p.m.	Paintfest– Sponsored by BBVA Compass
6:00 p.m. – 7:30 p.m.	LinkedIn Corner & Headshot Lounge – Sponsored by BB&T
6:00 p.m. – 7:30 p.m.	Golf Simulator – Sponsored by DadeSystems
7:30 p.m. – 9:30 p.m.	AFP 2019 Kick-Off Party @ Jillian’s Lucky Strike & Loretta’s Last Call

**Monday, October 21**

7:30 a.m. – 5:00 p.m.	Registration
7:30 a.m. – 5:00 p.m.	AFP Executive Institute Lounge– Sponsored by PNC
7:30 a.m. – 8:30 a.m.	Attendee Breakfast
7:30 a.m. – 5:00 p.m.	Speaker Ready Room
8:00 a.m. – 9:30 a.m.	Payments Breakfast – Sponsored by Bottomline Technologies, Discover Financial Services, Fiserv and NACHA
8:00 a.m. – 9:30 a.m.	AFP Executive Breakfast – Sponsored by RBC
8:00 a.m. – 5:00 p.m.	2020 Advanced Priority Space Selection Meeting
8:30 a.m. – 9:30 a.m.	Concurrent Educational Sessions
8:30 a.m. – 5:00 p.m.	Exhibit Hall Open
8:30 a.m. – 5:00 p.m.	Golf Simulator – Sponsored by DadeSystems
8:30 a.m. – 5:30 p.m.	AFP Conversations Podcast – Sponsored by Santander
8:30 a.m. – 5:00 p.m.	LinkedIn Corner & Headshot Lounge - Sponsored by BB&T
8:30 a.m. – 5:00 p.m.	Paintfest – Sponsored by BBVA Compass
8:30 a.m. – 5:00 p.m.	CTP Exam Review Course – Day 3 of 3
9:00 a.m. - 1:00 p.m.	AFP Aware Puppy Park
9:30 a.m. – 10:30 a.m.	Exhibit Hall Refreshment Break
9:45 a.m. – 10:15 a.m.	Executive Coaching – Sponsored by RTP
9:50 a.m. – 10:20 a.m.	Learning Lounge Sessions 1 and 2 – Sponsored by SunTrust
9:50 a.m. – 10:20 a.m.	MindShift Stage Presentation
10:30 a.m. – 11:45 a.m.	Concurrent Educational Sessions
10:30 a.m. – 11:45 a.m.	AFP Executive Institute Session– Sponsored by PNC
11:45 a.m. – 1:00 p.m.	Attendee Lunch

12:00 p.m. – 1:30 p.m.	Industry Roundtables Luncheon – Sponsored by Fifth Third Bank-Banking, Healthcare & Services, Energy & Utilities, Manufacturing
12:00 p.m. – 1:30 p.m.	AFP Executive Institute Luncheon, – Sponsored by PNC
12:30 p.m. – 1:45 p.m.	Exhibit Hall Dessert Reception
12:00 p.m. – 1:30 p.m.	FP&A Luncheon - Sponsored by Adaptive Insights, Host Analytics, OneStream Software and Vena Solutions
1:15 p.m. – 1:45 p.m.	Learning Lounge Sessions 3 and 4 – Sponsored by SunTrust
1:15 p.m. – 1:45 p.m.	MindShift Stage Presentation
2:00 p.m. – 3:00 p.m.	AFP Executive Institute Session – Sponsored by PNC
2:00 p.m. – 3:00 p.m.	Concurrent Educational Sessions
2:00 p.m. – 3:00 p.m.	Payments Roundtable – Accounts Payable, Sponsored by Tradeshift
2:00 p.m. – 3:00 p.m.	Industry Roundtables - Sponsored by Fifth Third Bank - Government, Retail, Insurance, Education & Non-Governmental Organizations
3:00 p.m. – 3:45 p.m.	Exhibit Hall Refreshment Break
3:30 p.m. – 3:45 p.m.	MindShift Keynote Doors Open
3:45 p.m. – 5:00 p.m.	MindShift Keynote – Sponsored by Capital One
5:00 p.m. – 6:00 p.m.	FP&A Reception – Sponsored by Adaptive Insights, Anaplan, Host Analytics, OneStream Software and Vena Solutions
5:00 p.m. – 6:00 p.m.	Payments Mixer – Sponsored by Bottomline Technologies, Discover Financial Services, Fiserv and NACHA

**Tuesday, October 22**

7:30 a.m. – 8:30 a.m.	Attendee Breakfast
7:30 a.m. – 3:00 p.m.	Registration
7:30 a.m. – 3:00 p.m.	Speaker Ready Room
7:30 a.m. – 3:00 p.m.	AFP Executive Institute Lounge– Sponsored by PNC
8:00 a.m. – 4:30 p.m.	2020 Advanced Priority Space Selection Meeting
8:00 a.m. – 5:00 p.m.	AFP Conversations Podcast – Sponsored by Santander
8:30 a.m. – 5:30 p.m.	Exhibit Hall Open
8:30 a.m. – 5:30 p.m.	Golf Simulator – Sponsored by DadeSystems
8:30 a.m. – 5:30 p.m.	LinkedIn Corner & Headshot Lounge, Sponsored by BB&T
8:30 a.m. – 1:00 p.m.	Paintfest – Sponsored by BBVA Compass
8:30 a.m. – 9:30 a.m.	Concurrent Educational Sessions
8:30 a.m. – 9:30 a.m.	AFP Executive Institute Session – Sponsored by PNC
8:30 a.m. – 9:30 a.m.	Payments Roundtable - Accounts Receivables
9:30 a.m. – 10:30 a.m.	Exhibit Hall Refreshment Break
9:40 a.m. – 10:10 a.m.	Executive Coaching – Sponsored by RTP
9:50 a.m. – 10:20 a.m.	Learning Lounge Sessions 5 and 6 – Sponsored by SunTrust
9:50 a.m. – 10:20 a.m.	MindShift Stage Presentation

10:30 a.m. – 11:45 a.m.	Concurrent Educational Sessions
10:30 a.m. – 11:45 a.m.	AFP Executive Institute Session – Sponsored by PNC
11:45 a.m. – 1:00 p.m.	Attendee Lunch
12:00 p.m. – 1:30 p.m.	Certification Luncheon – Sponsored by PNC
12:00 p.m. – 1:30 p.m.	AFP Executive Institute Luncheon – Sponsored by PNC
12:00 p.m. - 4:00 p.m.	AFP Aware Puppy Park
1:00 p.m. – 1:45 p.m.	Exhibit Hall Dessert Reception
1:00 p.m. – 1:30 p.m.	Learning Lounge Sessions 7 and 8 – Sponsored by SunTrust
1:00 p.m. – 1:30 p.m.	MindShift Stage Presentation
1:45 p.m. – 3:00 p.m.	Concurrent Educational Sessions
1:45 p.m. - 3:00 p.m.	Executive Roundtable – Sponsored by RTP
3:00 p.m. – 3:15 p.m.	Tuesday Keynote Doors Open
3:15 p.m. – 4:30 p.m.	Tuesday Keynote
4:30 p.m. – 5:30 p.m.	Exhibit Hall Closing Reception

**Wednesday, October 23**

7:30 a.m. – 8:30 a.m.	Attendee Breakfast
8:00 a.m. – 9:30 a.m.	Registration
7:30 a.m. – 10:00 a.m.	Speaker Ready Room
8:30 a.m. – 9:30 a.m.	Concurrent Educational Sessions
8:30 a.m. - 9:30 a.m.	FP&A Roundtable
9:30 a.m. – 10:00 a.m.	Attendee Refreshment Break
10:00 a.m. – 11:00 a.m.	Concurrent Educational Sessions

\*schedule as of 6/15/19

## AFP 2019 EXHIBIT HALL FLOOR PLAN

To view the exhibit hall floor plan, please visit:  
<https://conference.afponline.org/exhibitors-sponsors/exhibitors/floor-plan>

### CURRENT EXHIBITORS (As of June 1, 2019)

\*Refer to the online exhibit hall floor plan for the most updated list of exhibitors.

**-#-**

360T  
9<sup>th</sup> Gear Technologies

**-A-**

Accuity  
ACH Alert  
ACOM Solutions  
Adaptive Insights  
AFP Membership  
AFP Regional Booth  
Alacriti  
AllianceBernstein  
Alteryx  
American Express  
American Security Products  
Anaplan  
AscendantFX Capital Inc  
Avalara CertCapture  
Axletree Solutions

**-B-**

BANCO BRADESCO  
Bank Mendes Gans NV-ING  
Bank of America Merrill Lynch  
Barclays Bank  
BBVA Compass  
BELLIN  
Billtrust

Blackline Systems  
BlackRock  
Bloomberg LP  
BMO  
BNP Paribas/Bank of the West  
BOARD International  
Bottomline Technologies  
Brinks

**-C-**

C2FO  
Cachematrix  
Capital Advisors Group  
Capital One  
Cashbook Limited  
CASHFORCE NV  
Centage  
Center ID  
Centralis Group  
Certify, Inc.  
Chargeback Gurus  
Chatham Financial  
CheckAlt  
Checkbook.io  
CIMA Cash Handling, America  
CIT Bank  
Citi  
Citizens Commercial Banking  
City National Bank

Claims Compensation Bureau  
Clearwater Analytics  
Comdata  
Commerce Bank  
Compircus  
Computershare  
Conference Cafe - BNY Mellon  
Coproprocess  
Corcentric  
Corporate Spending  
Innovations (CSI)  
Crane Data  
Creditsafe

**-D-**

DadeSystems  
Danske Bank  
DBS Bank  
Deloitte  
Deluxe Corp  
Deluxe Treasury Management  
Derivative Path  
Deutsche Bank  
Digitech Systems LLC  
DVI  
DWS

**-E-**

Elire  
Ellenby  
Ernst & Young  
Esker

**-F-**

Federated Investors, Inc  
Fidelity Investments  
Fides Treasury Services Ltd.  
Fifth Third Bank  
Financial Sciences Corp  
Finastra  
FireKing Security  
FIS  
Fiserv Solutions  
Fitch Ratings  
FloQast, Inc.  
FTI Treasury  
FTNI

**-G-**

GIACT  
Global Cash Card  
Globalization Partners  
Glory Global Solutions  
Goby  
Goldman Sachs  
Golf Simulator Sponsored by  
DadeSystems  
GPS Capital Markets  
GTreasury

**-H-**

Harland Clarke  
Hedge Trackers  
HighRadius  
Host Analytics  
HSBC Bank USA

**-I-**

ICBC  
ICD

ImageScan  
Infor  
Informa Financial  
InfoStore  
Integro USA  
INTL FCStone Ltd  
Invesco  
ION  
IQ Backoffice  
iStream Financial Services

**-J-**

Jedox  
JP Morgan  
JP Morgan Asset Management

**-K-**

Kern Inc  
KeyBank  
Kyriba

**-L-**

Lamont Hanley & Assoc  
Learning Lounge 1 Sponsored by  
Suntrust  
Learning Lounge 2 Sponsored by  
Suntrust  
LeaseAccelerator Services  
Lighthouse Payment Services  
LinkedIn Corner sponsored  
by BB&T  
Lloyds Bank  
Loomis

**-M-**

M&T Bank  
MarketSphere Unclaimed  
Property Specialists  
MasterCard  
Mavro Imaging  
Merganser Capital Management  
Microsoft

MineralTree  
Mizuho Securities  
Morgan Stanley  
MUFG Union Bank, N.A  
MyOnlineBill

**-N-**

NACHA  
nanopay Corporation  
nCino  
NEACH  
NetSpend  
Neuberger Berman  
Northern Trust Co

**-O-**

OANDA  
OneStream Software  
Order2Cash  
OSG/Paybox

**-P-**

Pacific Life Insurance  
PaintFest  
Paychex  
Payden & Rygel  
PayStand  
Pelican  
Phoenix Hecht  
Piper Jaffrey  
Priority Commercial  
Payments  
ProAmpac  
Promontory Interfinancial  
Network, LLC  
Prudential Retirement  
PSI  
PwC

**-Q-**

Q&A Payment Solutions Inc  
Q2

**-R-**

Radius Bank  
RBC Global Asset Management  
Redbridge DTA  
Refinitiv  
Regions Bank  
Rice University  
Rimilia  
Ryan LLC

**-S-**

SAFEChecks  
Santander Bank  
Serrala  
Snapcheck  
Societe Generale  
Standard Bank Group  
Standard Chartered Bank  
State Street Global Markets  
StoneCastle  
Strategic Treasurer, LLC  
SunTrust  
SUZOHAPP  
SWIFT

**-T-**

Taulia  
TD Bank  
Tennessee Department of  
Commerce & Insurance  
Tesorio  
The Clearing House Payments Co  
The RWC Group  
Tidel

**TIS**

Toyota Financial Services  
Tradeshift  
Transactis  
TransCard  
TransferMate  
Treasury Partners  
TreasuryPay, Inc.  
TreasuryXpress  
Troy Group  
True Partners Consulting LLC

**-U-**

U.S. Bank  
U.S. Bankcorp Asset  
Management  
UBS Financial Services  
UMB Bank  
UniCredit Bank  
University of Connecticut

**-V-**

Vena Solutions  
Versapay  
Visa, Inc.

**-W-**

Wells Fargo  
West Monroe Partners, LLC  
Western Asset Management  
Western Union  
WEX  
Workiva  
Worldpay

**-X-**

XMLdation

**-Z-**

Zanders

## HOUSING AND CONFERENCE HOTEL INFORMATION

### HOUSING

All sleeping room and suite assignments for exhibitors and sponsors should be made through Convention Management Resources (CMR), AFP's official housing bureau. Online housing reservations can be made at: <https://www5.cmrhousing.com/afp2019/gp/EXHB/Housing/ResHotel>

### ADVANTAGES OF AFP HOUSING

Rates are negotiated based on our history (number of reservations). There are many price points available.

By using AFP Housing, you show your support for AFP and can take advantage of the benefits of an AFP annual conference attendee (negotiated room rates and complimentary shuttle to all conference events). AFP contracts with the hotels for the maximum block allowable. AFP reserves the right to reassign room blocks.

Page | 31

Exhibitors and sponsors are limited to the number of rooms at the conference headquarter hotel, Westin Boston Waterfront.

### DISADVANTAGES OF HOUSING OUTSIDE OF AFP'S BLOCK

Attendees pay a higher per night rate than AFP has negotiated with the hotels and assume any liability associated with the cancellation. Attendees staying at hotels outside the AFP room block will be responsible for their own transportation to conference events.

We hope you will take advantage of the amenities offered by AFP Housing, and we encourage you to continue to show support for AFP through our available housing options.

If you have any questions, AFP Housing can be reached at:

Phone: 800.618.4242 or 415.979.2269

Email: <https://afp.cmrushelp.com/customer/portal/emails/new>

### ROOMING LISTS

Exhibitor Room lists are due no later than **Friday, August 23, 2019**.

### CANCELLATION OF HOTEL ROOMS

AFP reserves the right to cancel any hotel reservations for individuals not registered to attend AFP 2019 by **Friday, September 20, 2019**. All reservations made online require a credit card to guarantee the reservation.

## HOUSING AND SHUTTLE INFORMATION

For more details about housing, go to:

<https://www5.cmrhousing.com/afp2019/gp/EXHB/Housing/ResHotel>

### Walking Distance Hotels

1. Aloft Boston Seaport
2. Element Boston Seaport
3. Seaport Hotel
4. Renaissance Boston Waterfront
5. Westin Boston Waterfront

Page | 32

### Hotel Shuttle Service

Complimentary shuttle service, sponsored by Fidelity, is offered from hotels in the AFP block not within walking distance of the Boston Convention and Exhibition Center.

Keep in mind that shuttle routes can service multiple hotels and include multiple stops. Be sure to arrive early to your nearest boarding location and allow ample time to get to the Boston Convention and Exhibition Center. Other factors like traffic could affect your arrival time so always allow more time to get to your destination.

Visit <https://conference.afponline.org/hotel-travel/while-here/shuttle> for the most up-to-date hotel shuttle service information.

To view the full list of partner hotels, shuttle routes and schedules download the [shuttle flyer](#).

## MEDIA COVERAGE

### DELIVERING YOUR MESSAGE

AFP is available to assist you in delivering your message to on-site media. Media can apply for a press pass by visiting [www.afpconference.org/media](http://www.afpconference.org/media).

If you plan to make a major announcement regarding a product or service, please contact [pr@AFPonline.org](mailto:pr@AFPonline.org) to receive a conference press attendee list. You will receive periodic updates of this media list as we get closer to the event.

## **SECTION VI**

### **AFP PROMOTIONAL OPPORTUNITIES**

## MARKETING AND SPONSORSHIP OPPORTUNITIES

AFP 2019 is the largest and most comprehensive financial event in the country. Financial professionals from across the world attend for three-and-a-half days of networking and professional development. This is your greatest opportunity to gain company exposure and name recognition. AFP offers many ways to access key decision makers in the finance and treasury industry. Below are the opportunities AFP has for increasing the visibility of your company at the annual conference.

For more information on marketing and sponsorship opportunities, visit this link:  
<https://conference.afponline.org/exhibitors-sponsors/sponsors/sponsorship-opportunities>

**TO ENSURE YOUR COMPANY RECEIVES MAXIMUM EXPOSURE, WE ENCOURAGE YOU TO PURCHASE ANY SPONSORSHIPS BY JULY 12<sup>th</sup>.**

Page | 35

Can't decide which of the sponsorship packages to select? Need complete details of a specific sponsorship? Want to generate a customized sponsorship?

Contact the AFP Sales Team and they will work with you to answer your questions, provide you additional details or customize a sponsorship for your needs. The AFP Sales Team can be reached at 301.961.8861 or [email](#).

## ADVERTISING OPPORTUNITIES

A request/order form for these products is located in the Appendix.  
Alternatively, you can contact the AFP Sales Team for more information at 301.961.8861.

### AFP EXCHANGE

Get your message in front of more than 25,000 dedicated readers, with titles ranging from chief financial officer and vice president of finance to treasurer and cash manager.

AFP *Exchange* is a forum for an exchange of knowledge and ideas. Its articles cover best practices and case studies on a variety of financial topics including cash and treasury management, corporate finance, international risk, pensions and investments and career management. It was first published in 1980 and is distributed to all AFP members, as well as to organizations around the world.

Below is a listing of the remaining issues this year and the main themes of the magazine. The Fall issue of *Exchange* will be distributed to all AFP Annual Conference attendees.

### ISSUES REMAINING IN 2019

#### Available Issues:

##### Fall

Main Theme: Fintech  
Sub-themes: Artificial Intelligence,  
Blockchain, Machine Learning

#### Insertion Orders due by:

Aug 9

#### Materials due by:

Aug 16

#### Available Issues:

##### Winter

Main Theme: AFP 2019  
Bonus Distribution at AFP 2019!

#### Insertion Orders due by:

Sept 24

#### Materials due by:

Oct 10

### ADVERTISING SPECIFICATIONS & RATES

For more information, including ad material specifications and rates, go to:  
<http://www.afponline.org/pub/s/print.html>

A request/order form for these products is located in the Appendix.  
Alternatively, you can contact the AFP Sales Team for more information at 301.961.8861.

### **ANNUAL CONFERENCE MOBILE APP**

The Annual Conference Mobile App will be the place to go for all details on events, concurrent sessions, general sessions, speakers, exhibitors and much more. Attendees will use the app to plan out their day-to-day activities for the annual conference.

### **COMPANY DESCRIPTIONS**

#### **DEADLINE: JUNE 30**

Each exhibitor/sponsor is entitled to a basic profile in the conference mobile app. Each profile may include:

- Company Name
- Booth #
- Address
- Phone
- Web site address
- Company description (90 words maximum)
- Select up to 4 product categories for your company to appear under

Enter your information through the online [exhibitor portal](#). AFP will include your company's information in our mobile app **exactly as you enter it on this page**, so be sure to input your information accurately.

### **COMPANY LOGO**

If you would like your company logo to be displayed in the mobile app alongside your company contact information, please upload your clearly labeled color company logo in EPS vector format through the online [exhibitor portal](#).

Our mobile app is scheduled to go live on July 1, 2019 so we encourage you to input your information ASAP. The mobile app will also be updated prior to conference. If you want to be listed in our mobile app, please provide your company information and logo no later than **August 23, 2019**.

### **ELECTRONIC NEWSLETTERS**

AFP's website and newsletters offer industry-leading resources and content in areas such as bank relationship management, payment resources, supply chain management, career services, risk, liquidity management and more. For the latest version of the above e-newsletters, go to <http://www.afponline.org/pub/s/online.html>

### **AFP TREASURY & FINANCE WEEK**

AFP's weekly e-newsletter, AFP Treasury & Finance Week, is a member benefit and is sent to over 16,000 financial professionals weekly. It delivers the latest information on treasury and cash management, corporate finance, financial accounting and reporting, pensions and benefits, electronic commerce and technology, career leadership and job postings. Similar in format, AFPC Treasury & Finance Week is a targeted e-newsletter that allows you to reach a Canadian audience.

### **AFP TREASURY INSIGHTS**

Treasury Insights is a monthly newsletter by, and for, corporate treasury professionals. TI offers peer insights and best practices as well as expert analysis and regulatory updates to help treasury professionals advance their organization—and their career. Topics include cash management, payments, cybersecurity, liquidity management, investing, risk management, bank relationship management, and more.

### **AFP WEB ADVERTISING**

Raise awareness, generate interest and drive traffic to your Web site.

### **TOPIC & ARTICLE PAGES**

Topic and article pages are an excellent resource for AFP's audience to look for the latest news in the finance industry. Get exposure up to 6,000 page views per month. Place a skyscraper ad that links to your company's web page and raise awareness by promoting your company as a key resource for financial professionals.

### **SPONSORED WHITE PAPERS**

AFP offers your company's white paper to be advertised on our website. Deliver your content directly to thousands of finance and treasury decision makers while they are researching solutions. And website visitors can also find your white paper via the search feature.

## **SECTION VII**

### **AFP ORDER/REQUEST FORMS**



# AFP EXCHANGE ADVERTISING

FOR QUESTIONS OR MORE INFORMATION: AFP Sales Department, 4520 East-West Highway, Suite 800, Bethesda, MD 20814 | Phone: 301.961.8861

MATERIALS SHOULD BE EMAILED TO: ads@AFPonline.org | Ads must arrive no later than 3 p.m. on the Friday prior to the scheduled run date.

Please type or print.

Advertiser Name: \_\_\_\_\_

Contact Name: \_\_\_\_\_

Address 1: \_\_\_\_\_

Address 2: \_\_\_\_\_

City: \_\_\_\_\_

State/Province: \_\_\_\_\_ Zip/Postal Code: \_\_\_\_\_ Country: \_\_\_\_\_

Phone: \_\_\_\_\_ Email: \_\_\_\_\_

Agency Name: \_\_\_\_\_

Billing Contact: \_\_\_\_\_

Address 1: \_\_\_\_\_

Address 2: \_\_\_\_\_

City: \_\_\_\_\_

State/Province: \_\_\_\_\_ Zip/Postal Code: \_\_\_\_\_ Country: \_\_\_\_\_

Phone: \_\_\_\_\_ Email: \_\_\_\_\_

## PRICING INFORMATION

Recognized advertising agencies receive a 15% discount. Rates are based on the number of insertions placed in a calendar year.

Standard Pages	1x	2x	3x	4x	Premium Pages	1x	2x	3x	4x
Full Page	\$6,950	\$6,250	\$5,600	\$5,100	IFC (Cover 2)	\$8,700	\$7,900	\$7,100	\$6,400
2-Page Spread	\$13,500	\$12,150	\$10,900	\$9,800	IBC (Cover 3)	\$8,000	\$7,250	\$6,500	\$5,900
Half-Page Spread	\$3,800	\$3,400	\$3,100	\$2,800	BC (Cover 4)	\$9,400	\$8,500	\$7,600	\$6,900
Third-Page	\$2,500	\$2,250	\$2,025	\$1,800	Gtd. pg 3, 5, & 7	\$7,300	\$6,500	\$5,900	\$5,300
Quarter-Page	\$2,000	\$1,800	\$1,600	\$1,450					

AFP reserves the right, at any time and for any reason in its discretion, to reject, cancel or cease publication of any ad materials, space reservation, or position. All advertising and ad materials are subject to acceptance/approval by AFP. Advertising format and specifications are subject to change.

An advertiser or agency canceling after the Ad Space Reservation Deadline must pay the full charge for the space reserved. Previous advertisements will be repeated if artwork is not received by the materials due date. AFP holds the advertiser and its agency jointly and severally liable for payment.

Client Signature: \_\_\_\_\_ Date: \_\_\_\_\_

AFP Representative Signature: \_\_\_\_\_ Date: \_\_\_\_\_

**You must complete both pages of this registration form.**



# AFP EXCHANGE ADVERTISING

You must complete both pages of this registration form.

## INDICATE YOUR AD PLACEMENTS

2019

---

SPRING (MARCH)

---

SUMMER (JUNE)

---

FALL - CONFERENCE (OCTOBER)

---

WINTER (DECEMBER)

---

Ad Size: \_\_\_\_\_

Frequency: \_\_\_\_\_

Rate: \_\_\_\_\_

TOTAL: \_\_\_\_\_

**Payment Terms:** All payments are payable in U.S. dollars only and are due within 30 days of invoice.

## MATERIALS & SPECIFICATIONS INFORMATION

### Preferred Materials:

- Print-ready PDF files, saved at 300 dpi or higher with crop marks and bleed allowance of 0.125". Embedded images must be at least 300 dpi and CMYK format.
- All fonts must be embedded.
- All RGB and PMS colors must be converted to a CMYK.

### Advertisement Specifications:

- All sizes given in width x height (shown in inches), based on an 8.125" x 10.75" (trim) magazine. All specifications for bleed ads include bleed & gutter safeties.
- Standard trim for bleeds is 0.125".

Ad Size	Size (Trim) Width x Height	Bleed (Includes 0.125" allowance) Width x Height	Live Area (Safety allowance) Width x Height
Full Page	8.125 x 10.75		7.625 x 10.25
Full Page Bleed	8.125 x 10.75	8.375 x 11	7.625 x 10.25
2-Page Spread	16.25 x 10.75		15.75 x 10.25
2 Page Spread Bleed	16.25 x 10.75	16.5 x 11	15.75 x 10.25
Half-Page Horizontal	7 x 4.5		
Half-Page Horizontal Bleed	8.125 x 5	8.375 x 5.125	7.625 x 4.75
Half-Page Horizontal Spread	15.75 x 4.5		
Half-Page Horizontal Spread Bleed	16.25 x 5	16.5 x 5.125	15.75 x 4.75
Half-Page Vertical	3.375 x 9.25		
Half-Page Vertical Bleed	3.375 x 10.75	4 x 11	3.75 x 10.25
Third-Page Horizontal	7 x 3		
Third-Page Horizontal Bleed	8.125 x 3	8.375 x 3.625	7.625 x 3.25
Third-Page Vertical	2.25 x 9.25		
Third-Page Vertical Bleed	2.75 x 10.75	2.875 x 11	2.5 x 10.25
Quarter-Page Vertical	3.375 x 4.5		



# AFP INSIDE TREASURY NEWSLETTER

FOR QUESTIONS OR MORE INFORMATION: AFP Sales Department, 4520 East-West Highway, Suite 800, Bethesda, MD 20814 | Phone: 301.961.8861

MATERIALS SHOULD BE EMAILED TO: ads@AFPonline.org | Ads must arrive no later than 3 p.m. on the Thursday prior to the scheduled run date.

Please type or print.

Advertiser Name: \_\_\_\_\_  Invoice Advertiser

Contact Name: \_\_\_\_\_

Address 1: \_\_\_\_\_

Address 2: \_\_\_\_\_

City: \_\_\_\_\_

State/Province: \_\_\_\_\_ Zip/Postal Code: \_\_\_\_\_ Country: \_\_\_\_\_

Phone: \_\_\_\_\_ Email: \_\_\_\_\_

Agency Name: \_\_\_\_\_  Invoice Agency

Contact Name: \_\_\_\_\_

Address 1: \_\_\_\_\_

Address 2: \_\_\_\_\_

City: \_\_\_\_\_

State/Province: \_\_\_\_\_ Zip/Postal Code: \_\_\_\_\_ Country: \_\_\_\_\_

Phone: \_\_\_\_\_ Email: \_\_\_\_\_

## PRICING INFORMATION

Position	1x	3x	6x	
First position	\$2,000	\$1,900	\$1,700	Ad position: _____
Second position	\$1,700	\$1,600	\$1,400	Frequency: _____
				Rate: _____

Recognized advertising agencies receive a 15% discount.

TOTAL: \_\_\_\_\_

**Payment Terms:** All payments are payable in U.S. dollars only and are due within 30 days of invoice.

AFP reserves the right, at any time and for any reason in its discretion, to reject, cancel or cease publication of any ad materials, space reservation, or position. All advertising and ad materials are subject to acceptance/approval by AFP. Advertising format and specifications are subject to change.

An advertiser or agency canceling after the Ad Space Reservation Deadline must pay the full charge for the space reserved. Previous advertisements will be repeated if artwork is not received by the materials due date. AFP holds the advertiser and its agency jointly and severally liable for payment.

Client Signature: \_\_\_\_\_ Date: \_\_\_\_\_

AFP Representative Signature: \_\_\_\_\_ Date: \_\_\_\_\_

**You must complete both pages of this registration form.**



# AFP INSIDE TREASURY NEWSLETTER

You must complete both pages of this registration form.

## INDICATE YOUR AD PLACEMENTS

### FIRST-POSITION ADS – 2019

<input type="checkbox"/> JAN 17	<input type="checkbox"/> FEB 21	<input type="checkbox"/> MAR 21	<input type="checkbox"/> APR 18	<input type="checkbox"/> MAY 16	<input type="checkbox"/> JUN 20	<input type="checkbox"/> JUL 18
<input type="checkbox"/> AUG 15	<input type="checkbox"/> SEP 19	<input type="checkbox"/> OCT 17	<input type="checkbox"/> NOV 21	<input type="checkbox"/> DEC 19		

### SECOND-POSITION ADS – 2019

<input type="checkbox"/> JAN 17	<input type="checkbox"/> FEB 21	<input type="checkbox"/> MAR 21	<input type="checkbox"/> APR 18	<input type="checkbox"/> MAY 16	<input type="checkbox"/> JUN 20	<input type="checkbox"/> JUL 18
<input type="checkbox"/> AUG 15	<input type="checkbox"/> SEP 19	<input type="checkbox"/> OCT 17	<input type="checkbox"/> NOV 21	<input type="checkbox"/> DEC 19		

## DEADLINE & SPECIFICATIONS INFORMATION

### Materials Deadline:

- Materials are due by 3 p.m. on the Thursday before the advertisement is scheduled to run.  
Example: Advertisement to run on Thursday, November 21, 2019; materials are due by 3 p.m., Thursday, November 14, 2019.

### Advertisement Specifications:

- Image: 180 x 180 pixels at 72 DPI
- Files with a white background must also have a 1 pixel border
- Title: 50 characters maximum
- Body Copy: 225 characters maximum
- Call to Action Link: 30 characters maximum
- URL for Call to Action link



# AFP TREASURY & FINANCE WEEK

FOR QUESTIONS OR MORE INFORMATION: AFP Sales Department, 4520 East-West Highway, Suite 800, Bethesda, MD 20814 | Phone: 301.961.8861

MATERIALS SHOULD BE EMAILED TO: ads@AFPonline.org | Ads must arrive no later than 12 p.m. on the Thursday prior to the scheduled run date.

Please type or print.

Advertiser Name: \_\_\_\_\_  Invoice Advertiser

Contact Name: \_\_\_\_\_

Address 1: \_\_\_\_\_

Address 2: \_\_\_\_\_

City: \_\_\_\_\_

State/Province: \_\_\_\_\_ Zip/Postal Code: \_\_\_\_\_ Country: \_\_\_\_\_

Phone: \_\_\_\_\_ Email: \_\_\_\_\_

Agency Name: \_\_\_\_\_  Invoice Agency

Contact Name: \_\_\_\_\_

Address 1: \_\_\_\_\_

Address 2: \_\_\_\_\_

City: \_\_\_\_\_

State/Province: \_\_\_\_\_ Zip/Postal Code: \_\_\_\_\_ Country: \_\_\_\_\_

Phone: \_\_\_\_\_ Email: \_\_\_\_\_

## PRICING INFORMATION

Position	1x	3x	6x	
First position	\$2,000	\$1,900	\$1,700	Ad position: _____
Second position	\$1,700	\$1,600	\$1,400	Frequency: _____
Recognized advertising agencies receive a 15% discount.				Rate: _____
				TOTAL: _____

**Payment Terms:** All payments are payable in U.S. dollars only and are due within 30 days of invoice.

AFP reserves the right, at any time and for any reason in its discretion, to reject, cancel or cease publication of any ad materials, space reservation, or position. All advertising and ad materials are subject to acceptance/approval by AFP. Advertising format and specifications are subject to change.

An advertiser or agency canceling after the Ad Space Reservation Deadline must pay the full charge for the space reserved. Previous advertisements will be repeated if artwork is not received by the materials due date. AFP holds the advertiser and its agency jointly and severally liable for payment.

Client Signature: \_\_\_\_\_ Date: \_\_\_\_\_

AFP Representative Signature: \_\_\_\_\_ Date: \_\_\_\_\_

**You must complete both pages of this registration form.**



# AFP TREASURY & FINANCE WEEK

You must complete both pages of this registration form.

## INDICATE YOUR AD PLACEMENTS

### FIRST-POSITION ADS — 2019

<input type="checkbox"/> JAN 2	<input type="checkbox"/> JAN 9	<input type="checkbox"/> JAN 16	<input type="checkbox"/> JAN 23	<input type="checkbox"/> JAN 30	<input type="checkbox"/> FEB 6	<input type="checkbox"/> FEB 13	<input type="checkbox"/> FEB 20
<input type="checkbox"/> FEB 27	<input type="checkbox"/> MAR 6	<input type="checkbox"/> MAR 13	<input type="checkbox"/> MAR 20	<input type="checkbox"/> MAR 27	<input type="checkbox"/> APR 3	<input type="checkbox"/> APR 10	<input type="checkbox"/> APR 17
<input type="checkbox"/> APR 24	<input type="checkbox"/> MAY 1	<input type="checkbox"/> MAY 8	<input type="checkbox"/> MAY 15	<input type="checkbox"/> MAY 22	<input type="checkbox"/> MAY 29	<input type="checkbox"/> JUN 5	<input type="checkbox"/> JUN 12
<input type="checkbox"/> JUN 19	<input type="checkbox"/> JUN 26	<input type="checkbox"/> JUL 3	<input type="checkbox"/> JUL 10	<input type="checkbox"/> JUL 17	<input type="checkbox"/> JUL 24	<input type="checkbox"/> JUL 31	<input type="checkbox"/> AUG 7
<input type="checkbox"/> AUG 14	<input type="checkbox"/> AUG 21	<input type="checkbox"/> AUG 28	<input type="checkbox"/> SEP 4	<input type="checkbox"/> SEP 11	<input type="checkbox"/> SEP 18	<input type="checkbox"/> SEP 25	<input type="checkbox"/> OCT 2
<input type="checkbox"/> OCT 9	<input type="checkbox"/> OCT 16	<input type="checkbox"/> OCT 23	<input type="checkbox"/> OCT 30	<input type="checkbox"/> NOV 6	<input type="checkbox"/> NOV 13	<input type="checkbox"/> NOV 20	<input type="checkbox"/> NOV 27
<input type="checkbox"/> DEC 4	<input type="checkbox"/> DEC 11	<input type="checkbox"/> DEC 18	<input type="checkbox"/> DEC 25				

### SECOND-POSITION ADS — 2019

<input type="checkbox"/> JAN 2	<input type="checkbox"/> JAN 9	<input type="checkbox"/> JAN 16	<input type="checkbox"/> JAN 23	<input type="checkbox"/> JAN 30	<input type="checkbox"/> FEB 6	<input type="checkbox"/> FEB 13	<input type="checkbox"/> FEB 20
<input type="checkbox"/> FEB 27	<input type="checkbox"/> MAR 6	<input type="checkbox"/> MAR 13	<input type="checkbox"/> MAR 20	<input type="checkbox"/> MAR 27	<input type="checkbox"/> APR 3	<input type="checkbox"/> APR 10	<input type="checkbox"/> APR 17
<input type="checkbox"/> APR 24	<input type="checkbox"/> MAY 1	<input type="checkbox"/> MAY 8	<input type="checkbox"/> MAY 15	<input type="checkbox"/> MAY 22	<input type="checkbox"/> MAY 29	<input type="checkbox"/> JUN 5	<input type="checkbox"/> JUN 12
<input type="checkbox"/> JUN 19	<input type="checkbox"/> JUN 26	<input type="checkbox"/> JUL 3	<input type="checkbox"/> JUL 10	<input type="checkbox"/> JUL 17	<input type="checkbox"/> JUL 24	<input type="checkbox"/> JUL 31	<input type="checkbox"/> AUG 7
<input type="checkbox"/> AUG 14	<input type="checkbox"/> AUG 21	<input type="checkbox"/> AUG 28	<input type="checkbox"/> SEP 4	<input type="checkbox"/> SEP 11	<input type="checkbox"/> SEP 18	<input type="checkbox"/> SEP 25	<input type="checkbox"/> OCT 2
<input type="checkbox"/> OCT 9	<input type="checkbox"/> OCT 16	<input type="checkbox"/> OCT 23	<input type="checkbox"/> OCT 30	<input type="checkbox"/> NOV 6	<input type="checkbox"/> NOV 13	<input type="checkbox"/> NOV 20	<input type="checkbox"/> NOV 27
<input type="checkbox"/> DEC 4	<input type="checkbox"/> DEC 11	<input type="checkbox"/> DEC 18	<input type="checkbox"/> DEC 25				

## DEADLINE & SPECIFICATIONS INFORMATION

### Materials Deadline:

- Materials are due by 3 p.m. on the Wednesday before the advertisement is scheduled to run.
- Example: Advertisement to run on Wednesday, October 30, 2019; materials are due by 3 p.m., Wednesday, October 23, 2019.

### Advertisement Specifications:

- Image: 180 x 180 pixels at 72 DPI
- Files with a white background must also have a 1 pixel border
- Title: 50 characters maximum
- Body Copy: 225 characters maximum
- Call to Action Link: 30 characters maximum
- URL for Call to Action link



# AFP FP&A IN FOCUS NEWSLETTER

FOR QUESTIONS OR MORE INFORMATION: AFP Sales Department, 4520 East-West Highway, Suite 800, Bethesda, MD 20814 | Phone: 301.961.8861

MATERIALS SHOULD BE EMAILED TO: ads@AFPonline.org | Ads must arrive no later than 3 p.m. on the Thursday prior to the scheduled run date.

Please type or print.

Advertiser Name: \_\_\_\_\_  Invoice Advertiser

Contact Name: \_\_\_\_\_

Address 1: \_\_\_\_\_

Address 2: \_\_\_\_\_

City: \_\_\_\_\_

State/Province: \_\_\_\_\_ Zip/Postal Code: \_\_\_\_\_ Country: \_\_\_\_\_

Phone: \_\_\_\_\_ Email: \_\_\_\_\_

Agency Name: \_\_\_\_\_  Invoice Agency

Contact Name: \_\_\_\_\_

Address 1: \_\_\_\_\_

Address 2: \_\_\_\_\_

City: \_\_\_\_\_

State/Province: \_\_\_\_\_ Zip/Postal Code: \_\_\_\_\_ Country: \_\_\_\_\_

Phone: \_\_\_\_\_ Email: \_\_\_\_\_

## PRICING INFORMATION

Position	1x	3x	6x	
First position	\$2,000	\$1,900	\$1,700	Ad position: _____
Second position	\$1,700	\$1,600	\$1,400	Frequency: _____
				Rate: _____

Recognized advertising agencies receive a 15% discount.

TOTAL: \_\_\_\_\_

**Payment Terms:** All payments are payable in U.S. dollars only and are due within 30 days of invoice.

AFP reserves the right, at any time and for any reason in its discretion, to reject, cancel or cease publication of any ad materials, space reservation, or position. All advertising and ad materials are subject to acceptance/approval by AFP. Advertising format and specifications are subject to change.

An advertiser or agency canceling after the Ad Space Reservation Deadline must pay the full charge for the space reserved. Previous advertisements will be repeated if artwork is not received by the materials due date. AFP holds the advertiser and its agency jointly and severally liable for payment.

Client Signature: \_\_\_\_\_ Date: \_\_\_\_\_

AFP Representative Signature: \_\_\_\_\_ Date: \_\_\_\_\_

**You must complete both pages of this registration form.**



# AFP FP&A IN FOCUS NEWSLETTER

You must complete both pages of this registration form.

## INDICATE YOUR AD PLACEMENTS

### FIRST-POSITION ADS – 2019

<input type="checkbox"/> JAN 3	<input type="checkbox"/> FEB 7	<input type="checkbox"/> MAR 7	<input type="checkbox"/> APR 4	<input type="checkbox"/> MAY 2	<input type="checkbox"/> JUN 6	<input type="checkbox"/> JUL 11
<input type="checkbox"/> AUG 1	<input type="checkbox"/> SEP 5	<input type="checkbox"/> OCT 3	<input type="checkbox"/> NOV 7	<input type="checkbox"/> DEC 5		

### SECOND-POSITION ADS – 2019

<input type="checkbox"/> JAN 3	<input type="checkbox"/> FEB 7	<input type="checkbox"/> MAR 7	<input type="checkbox"/> APR 4	<input type="checkbox"/> MAY 2	<input type="checkbox"/> JUN 6	<input type="checkbox"/> JUL 11
<input type="checkbox"/> AUG 1	<input type="checkbox"/> SEP 5	<input type="checkbox"/> OCT 3	<input type="checkbox"/> NOV 7	<input type="checkbox"/> DEC 6		

## DEADLINE & SPECIFICATIONS INFORMATION

### Materials Deadline:

- Materials are due by 3 p.m. on the Thursday before the advertisement is scheduled to run.
- Example: Advertisement to run on Thursday, November 7, 2019; materials are due by 3 p.m., Thursday, October 31, 2019.

### Advertisement Specifications:

- Image: 180 x 180 pixels at 72 DPI
- Files with a white background must also have a 1 pixel border
- Title: 50 characters maximum
- Body Copy: 225 characters maximum
- Call to Action Link: 30 characters maximum
- URL for Call to Action link



# AFP 2019 CONFERENCE ADVERTISING

FOR QUESTIONS OR MORE INFORMATION: AFP Sales Department, 4520 East-West Highway, Suite 800, Bethesda, MD 20814 | Phone: +1 301.961.8861  
MATERIALS SHOULD BE EMAILED TO: ads@AFPonline.org

Please type or print.

Advertiser Name: \_\_\_\_\_

Agency Name: \_\_\_\_\_

Contact Name: \_\_\_\_\_

Address 1: \_\_\_\_\_

Address 2: \_\_\_\_\_

City: \_\_\_\_\_

State/Province: \_\_\_\_\_ Zip/Postal Code: \_\_\_\_\_ Country: \_\_\_\_\_

Phone: \_\_\_\_\_ Email: \_\_\_\_\_

## PRICING INFORMATION

AFP reserves the right, at any time and for any reason in its discretion, to reject, cancel or cease publication of any ad materials, space reservation, or position. All advertising and ad materials are subject to acceptance/approval by AFP. Advertising format and specifications are subject to change. An advertiser or agency canceling after September 1, 2019 must pay the full charge for the space reserved. AFP holds the advertiser and its agency jointly and severally liable for payment.

### AFP 2019 Mobile App Advertising

- Push Notifications: \$12,500
- Banner: \$7,500

### AFP 2019 Daily News

	Sunday	Monday	Tuesday
First Position: \$2,500			<input type="checkbox"/>
Second Position: \$2,250		<input type="checkbox"/>	<input type="checkbox"/>
Third Position: \$2,000	<input type="checkbox"/>	<input type="checkbox"/>	<input type="checkbox"/>

### Exhibit Hall Food Court Banner *Banner (5'h x 15' w)*

- Banner: \$6,000

### Digital Products Showcase

- Digital Products Showcase: \$2,500

### Registration Bag Insert *8.5 x 11" insert*

- Insert: \$6,500

### Session Evaluation Advertising by Track (\$3,500 each)

- Career Development
- Financial Planning & Analysis
- Capital Markets & Investments
- Payments
- Retirement Plans & Benefits
- Risk Management
- Treasury Management



# AFP 2019 CONFERENCE ADVERTISING

**AFP 2019 at-a-Glance Guide**

---

- Panel Ad: \$3,500       Back Cover: \$7,500

**Convention Center Digital Signage**

---

- Marquee: \$15,000       Video Wall: \$7,500       Network: \$3,500

**Exhibit Hall Carpet Decals**

---

- Carpet Decals: \$2,500

**Exhibit Hall Entrance Branding**

---

- Floor Decals: \$12,500       Staircase Graphics \$15,000

**Standalone**

---

- Standalone: \$5,000

**Signatures and Acknowledgement**

---

Client Signature: \_\_\_\_\_ Date: \_\_\_\_\_

AFP Representative Signature: \_\_\_\_\_ Date: \_\_\_\_\_

## **SECTION VIII**

### **PREFERRED VENDOR ORDER FORMS/BROCHURES**

# CREATE AN EXCEPTIONAL EXPERIENCE...

**CSI BOSTON**  
DESTINATION & EVENT MANAGEMENT

**LOOKING FOR BETTER ENGAGEMENT DURING AFP BOSTON?**  
CONTACT CSI BOSTON, THE OFFICIAL EVENT PLANNER AFP.



## **CREATE MEMORABLE EVENTS**

- Creative Themed Décor
- Exceptional Offsite Events
- Group Dinners
- Unique Entertainment
- Unforgettable Tours & Activities
- Teambuilding & Giveback Programs
- VIP Transportation

CSI is your strategic destination and event management resource bringing over three decades of verifiable success and diverse industry experience. We will serve as an extension of your team, enriching your time in Boston to help you get the most out of your conference experience.

At AFP and beyond, our commitment is simple: to create  
**AN EXCEPTIONAL EXPERIENCE, EVERY TIME...**



**REQUEST FOR BOARDING SPACE**



**BOSTON | OCTOBER 20-23**

This form is to be used by exhibitors and/or groups requesting boarding space at the Boston Conference & Exhibition Center (BCEC) for any bus moves during AFP 2019. Approved groups will be allowed one boarding space per move for active boarding only. *Additional vehicles will be required to stage off-site and be called up when space is available (due to space limitations, there will be no exceptions).*

To request an assigned slot, please complete this form and return to Kirsten Young ([k.young@kushnershuttles.com](mailto:k.young@kushnershuttles.com)) by **Friday, September 13, 2019**. Boarding space assignments will be confirmed by October 11.

Exhibitor/Group Name: \_\_\_\_\_

Onsite Contact: \_\_\_\_\_ Phone: \_\_\_\_\_

Email: \_\_\_\_\_ Cell phone: \_\_\_\_\_

Transportation Company contact: \_\_\_\_\_

Phone: \_\_\_\_\_ Email: \_\_\_\_\_

**Date of pick up:** \_\_\_\_\_ **# of vehicles** \_\_\_\_\_

Vehicle type: coach mini van limo sedan other \_\_\_\_\_  
(Please circle one)

Destination: \_\_\_\_\_

Departure time(s): \_\_\_\_\_  
*One vehicle can stage 15 minutes prior to the first departure*

Continuous shuttle or one-time departure?: \_\_\_\_\_

If continuous, frequency of service: \_\_\_\_\_

**\*\* Vehicles will not be allowed to return to BCEC to drop-off at the end of your event. Please plan on returning your guests directly to hotels or to a central location.**

Per AFP, in planning your attendee evening events, please do not schedule any events during these hours:

Sunday, October 20 – 7:00 am-10:00 pm  
\*Events may begin at 10:15 pm

Tuesday, October 22 – 8:30 am-5:30 pm  
\*Events may begin at 5:45 pm

Monday, October 21 – 8:00 am-6:00 pm  
\*Events may begin at 6:15 pm

Wednesday, October 23 – 8:30-11:00 am  
\*Events may begin at 11:15 am

CUSTOM DESIGNED ARRANGEMENTS	DESCRIPTION / COLOR	UNIT PRICE	QUANTITY	TOTAL
SPRING FLORAL ARRANGEMENT		65.00		
TROPICAL FLORAL ARRANGEMENT		75.00		
FLORAL ARRANGEMENT HEIGHT:      WIDTH:		100.00 or 175.00		
FLORAL ARRANGEMENT HEIGHT:      WIDTH:				
<b>TROPICAL PLANT AND BLOOMING FOLIAGE</b>				
MUM PLANTS: Yellow ____ White ____ Lavender ____		30.00		
AZALEAS: Pink ____ Red ____		35.00		
BROMELIAD		35.00		
SMALL Ivy ____ Pothos ____		30.00		
LARGE BOSTON FERN		40.00		
3 FOOT TROPICAL PLANT		49.50		
4 FOOT TROPICAL PLANT		59.50		
5 FOOT TROPICAL PLANT		69.50		
<b>CUSTOM TROPICAL PLANTS</b>				
5 FOOT TROPICAL / TOP DRESSED - SMALL IVY AND BLOOMING		125.00		
6 FOOT FICUS TREE / TOP DRESSED - SMALL IVY AND BLOOMING		169.50		
6 FOOT PALM / TOP DRESSED - SMALL IVY AND BLOOMING		169.50		
8 FOOT - 16 FOOT TROPICAL PLANT		Price on Request		
<b>CONTAINERS:</b> <input type="checkbox"/> WHITE <input type="checkbox"/> BLACK			<b>SUB-TOTAL</b>	
			<b>DELIVERY, PICK UP &amp; MAINTENANCE 10%</b>	
			<b>GRAND TOTAL</b>	

**ALL LIVE GREEN MATERIAL ON RENTAL BASIS ONLY.**  
**ALL ORDERS MUST BE PAID IN FULL PRIOR TO THE CLOSE OF THE SHOW.**  
 We accept Checks, VISA, MasterCard, and American Express.

Have National Plant & Floral's Designer call our booth on the following Date/Time: \_\_\_\_\_

**PAYMENT:**     VISA     MASTERCARD     AMEX     CHECK  
 CREDIT CARD #: \_\_\_\_\_  
 EXP DATE: \_\_\_\_\_ SECURITY CODE: \_\_\_\_\_  
 CARDHOLDER NAME: \_\_\_\_\_  
 AUTHORIZED SIGNATURE: \_\_\_\_\_  
 CREDIT CARD BILLING ADDRESS: \_\_\_\_\_  
 \_\_\_\_\_  
 CITY: \_\_\_\_\_  
 STATE: \_\_\_\_\_ ZIP CODE #: \_\_\_\_\_

COMPANY NAME: \_\_\_\_\_  
 BOOTH CONTACT: \_\_\_\_\_  
 PHONE#: (\_\_\_\_\_) \_\_\_\_\_  
 EMAIL: \_\_\_\_\_  
 EMAIL CONFIRMATION COPY     EMAIL STATEMENT COPY

**Please Remit to:**  
**1001 E. SUNSET # 95814 • LAS VEGAS, NV 89193**  
**(702) 956-8011 • FAX (702) 956-8021**  
 exhibitorservice@nationalplantfloral.com

# Win **MORE** Business with Advanced Lead Retrieval Tools

You've made the investment to exhibit, now get the **highest ROI** possible by capturing prospect information in just a few seconds. Expo Logic's lead retrieval tools make it easy to scan badges, qualify leads, and even follow-up with leads!

## LeadPod Pro

The LeadPod™ Pro app turns any iPhone, iPad or Android device into your own advanced lead retrieval tool. With the LeadPod Pro app you can scan an attendee's badge using the camera on your device, capture their contact information instantly, take notes on each lead, and survey your lead with customizable surveys.

You can also save a lead as a contact on your phone, place a call to your lead or send them an email or text message – all directly from the app! This functionality makes lead follow-up a breeze and ensures you get the most out of the leads you capture.

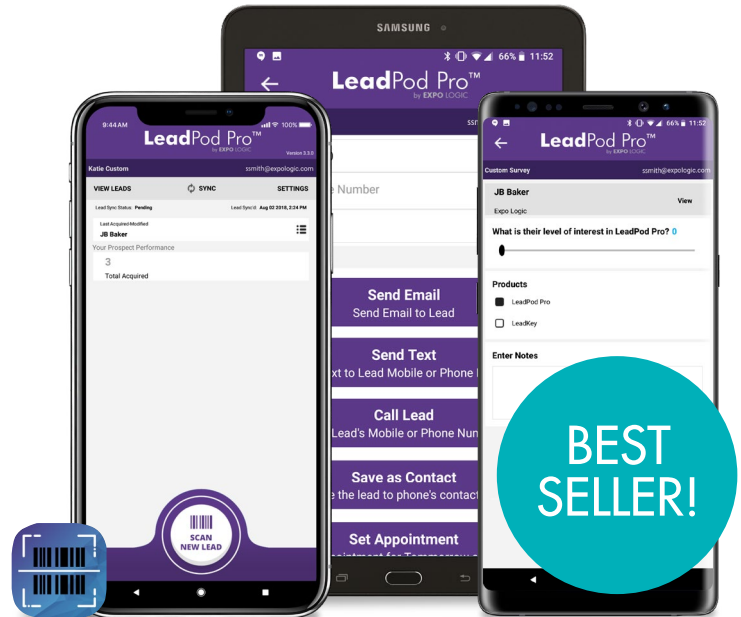

[LEARN MORE](#)

## Lead Manager

Lead Manager is a user-friendly, handheld device with a large touchscreen display. Lead Manager allows you to scan badges, collect leads quickly and view the lead information right on the device. The large screen makes reading the leads easy and gives you the option to enter notes right on the device.

[LEARN MORE](#)



To order online, go to [myexpoleads.expologic.com](http://myexpoleads.expologic.com) and use show code: **AFP2019**

If you would like to fax or mail your order to us there will be a \$7.95 processing fee.

## Lead Manager

Wireless battery operated unit that saves leads on-line for download at any time. New improved touch screen allows for easy note-taking & qualification.



## Printer for Lead Manager

Wireless, battery powered thermal printer connects to handheld scanners to print a hardcopy of each scan. Will operate from up to 50ft away and print 1000+ leads on a single charge. ONLY COMPATIBLE WITH LEAD MANAGER.



## LeadPod Pro

Mobile solution for iOS and Android devices, includes basic qualifiers and note-taking capability.

*\*Minimum iOS Version 9.0, Minimum Android Version 5.0. All devices require AutoFocus Cameras\**



### Device Selection

	Initial Price	Starting 8/30/19	Starting 10/11/19	QTY	TOTAL
<b>Lead Manager</b> Wireless battery operated unit with touch-screen note taking that saves leads on-line for download at any time.	\$355/1st Unit	\$405/1st Unit	\$455/1st Unit	___	\$ _____
	\$355/Addl.	\$405/Addl.	\$455/Addl.	___	\$ _____
<b>Printer for Lead Manager</b> Wireless, battery powered thermal printer.	\$125/1st Unit	\$125/1st Unit	\$125/1st Unit	___	\$ _____
	\$125/Addl.	\$125/Addl.	\$125/Addl.	___	\$ _____
<b>LeadPod Pro</b> Capture leads, take notes and more with this app.	\$285/1st Unit	\$335/1st Unit	\$385/1st Unit	___	\$ _____
	\$135/Addl.	\$185/Addl.	\$235/Addl.	___	\$ _____

### Additional Services

	COST	QTY	TOTAL
Insurance quantities must equal device quantities.			
<b>Lead Manager Insurance</b>	\$45 /each	___	\$ _____
Custom Qualifiers	\$95	___	\$ _____
Delivery	\$75	___	\$ _____
Insurance for Portable Printer	\$45	___	\$ _____
Custom Surveys	\$95	___	\$ _____

**PROCESSING FEE \$ 7.95**  
(for mail or fax)

**GRAND TOTAL \$ \_\_\_\_\_**

## Your Contact and Payment Information

Company		Billing Contact	
<input type="text"/>		<input type="text"/>	
Billing Street Address (Must match the billing address on the credit card being used for payment)			
<input type="text"/>			
City	State	Zip	
<input type="text"/>	<input type="text"/>	<input type="text"/>	
Phone	Fax		
<input type="text"/>	<input type="text"/>		
Email Address			
<input type="text"/>			
Cell Phone Number (for on-site contact)		Booth Number	
<input type="text"/>		<input type="text"/>	
Email Address (for on-site contact)			
<input type="text"/>			
First Name (for on-site contact)		Last Name (for on-site contact)	
<input type="text"/>		<input type="text"/>	

Credit Card (circle one if paying by credit card)		Check Number	Total Amount Due
<input type="checkbox"/> AMEX <input type="checkbox"/> VISA <input type="checkbox"/> MasterCard <input type="checkbox"/> Discover		<input type="text"/>	<input type="text"/>
Credit Card Number		CW	Expires
<input type="text"/>		<input type="text"/>	<input type="text"/>
Name as it appears on card		Signature	
<input type="text"/>		<input type="text"/>	

**TERMS & CONDITIONS:** It is understood the above-named Company is responsible for the pick-up, proper use, safeguarding, and prompt return of the Badge. Reader(s) in his/her possession and is also liable for any loss or damage. Expo Logic reserves the right to terminate services if the rented equipment is found to be improperly used. Replacement fee for lost, stolen, damaged LeadKey® is \$495.00/device. Replacement fee for lost, stolen, damaged Lead Manager is \$2,495.00/device. A credit card deposit will be required on-site if rental payment is made by check or cash. Badge readers must be picked up at our on-site service counter if you did not order 'Delivery' services. All equipment must be returned within 30 minutes after the close of the Show in its original packaging. Refunds will not be made for unclaimed equipment or if above Company decides not to use the ordered service. A \$7.95 processing fee will be added to faxed or mailed orders. It is against Expo Logic's security policy to accept credit card information via email.

**CANCELLATION POLICY:** You may cancel your order up to 2 weeks before the event's opening date. A \$50.00/Order Cancellation Fee will apply. No refunds will be given for orders cancelled less than 2 weeks prior to the event's opening date.  
 \*LeadPod users will have instant access to their leads, as long as the device has an active internet connection (WiFi, LTE/4G, 3G).

**\* CHECK or CREDIT CARD MUST ACCOMPANY ORDER \***

MAIL or FAX to:

**"Convention Photo by Joe Orlando, Inc."**

2222 Foothill Blvd, Suite E-340, La Cañada CA 91011 • Phone: 1.626.639.3015 • Fax: 1.626.794.0525

**Servicing Trade Shows in Las Vegas, NV and Nationally for over 50 years**

www.joeorlandophoto.com  
email: mail@joeorlandophoto.com

YOUR P.O. NUMBER

QUANTITY	SERVICES	EACH	TOTAL
_____	<b>COLOR ORIGINAL</b> <input type="checkbox"/> Includes Photography Time, 8x10 Print	@ \$95.00 \$	_____
	No People <input type="checkbox"/> Posed Staff <input type="checkbox"/> Crowd During Show <input type="checkbox"/>		
<b>Additional Photo Services After Original Ordered</b>			
_____	<b>HI RES DIGITAL IMAGE FROM COLOR ORIGINAL</b> <input type="checkbox"/> Includes release and rights of image, 300 dpi @ 8x10 saved as jpeg.	Per Image @ \$50.00 \$	_____
_____	<b>LOW RES DIGITAL IMAGE FROM COLOR ORIGINAL</b> <input type="checkbox"/> Includes image saved as jpeg @ 72 dpi, perfect for powerpoint / website.	Per Image @ \$35.00 \$	_____
_____	<b>COLOR 8x10 REPRINTS OF ORIGINALS</b>	Per Print @ \$35.00 \$	_____
_____	<b>PHOTOSHOP RETOUCHING</b> <input type="checkbox"/> 1 Hour Minimum.	Per Hour @ \$160.00 \$	_____
<b>DIGITAL PHOTOGRAPHY QUOTES</b>			
<ul style="list-style-type: none"><li>• Publicity, Banquets, Awards,</li><li>• On Site CD Burning</li><li>• Photoshop Retouching</li><li>• Website Hosting of Low Res Image (For publicity or associations)</li></ul>			
<input type="checkbox"/> Clients based in <u>California</u> add CA tax <input type="checkbox"/> Clients in other states no tax			→ TAX: \$ _____
All Orders add \$10.00 Shipping & Handling:			\$ <b>10.00</b>
Fed-Ex #: _____			<b>TOTAL: \$</b> _____
<b>SUB TOTAL: \$</b> _____			
<b>Green Screen</b> photography also available <b>Video Production</b> (upon availability, call for quotes)			

PLEASE PRINT:

Name of Convention: **AFP 2019**      Dates: **October 20-23, 2019**

Convention Hotel / Location: **Boston Convention and Exhibition Center.**

Daily Exhibit Hours: \_\_\_\_\_

Onsite Contact & Cell Phone Number: \_\_\_\_\_

Exhibitor: \_\_\_\_\_ Booth # & Size: \_\_\_\_\_

Display House: \_\_\_\_\_

Ship to Address: \_\_\_\_\_

Credit Card Billing Address: \_\_\_\_\_

City, State and Zip Code: \_\_\_\_\_

Telephone Number: (800) (    ) \_\_\_\_\_ E-mail: \_\_\_\_\_

Authorized Signature: \_\_\_\_\_

Credit Card Info: Please Circle One:    Credit Card-V code or Security Code: \_\_\_\_\_

Credit Card Number: \_\_\_\_\_ Expiration Date: \_\_\_\_\_

Card Holder Name: \_\_\_\_\_ Authorized Signature: \_\_\_\_\_



Remarkable experiences.  
Imagination realized.™

# MENU

## Exhibitor Catering



BOSTON CONVENTION & EXHIBITION CENTER AND JOHN B. HYNES  
VETERANS MEMORIAL CONVENTION CENTER



Remarkable experiences.  
Imagination realized.™

*A warm Boston*

WELCOME

Levy Convention Centers' Boston team is very proud to boast the most local food and beverage experience in our industry. As the exclusive food and beverage provider, Levy invites you to partner with our distinguished culinary team as you experience local flavor designed specifically for your event. As “a family of passionate restaurateurs” we seek to exceed your guests’ expectations by delighting them with delicious

food, creatively presented by friendly, helpful staff. Let us help make Boston an experience for your attendees that will go down in history!

# *A Family of Passionate Restaurateurs*



# PLAN WITH EASE

To help facilitate your event planning, please find below, our policies containing answers to your most frequently asked questions.

## GENERAL POLICIES

### GUARANTEES

In order to provide the highest quality and service, a guaranteed number of attendees/quantities of food is required. Please refer to your Catering Agreement for more details.

If the final guarantee is not received per the terms in your contract, Levy Convention Centers will assume the number of persons/quantities specified on the original contracted event order is the minimum guarantee. Attendance or consumption higher than the minimum guarantee will be charged as the actual event attendance or consumption.

### INCENTIVE/STANDARD PRICING TIME LINE

Incentive prices are valid for all orders placed more than twenty-one (21) days prior to the first day of the show.

Standard pricing applies to all orders placed 21 days or fewer, prior to the first day of the show.

### BAR SERVICE

For all events with alcohol service, a certified Levy Restaurants bartender is required. Bartenders are charged at \$175 per bartender with a 4 hour minimum. Each additional hour or portion thereof will be \$43.75 per bartender. Alcohol cannot be brought into or removed from the premises.

### SAMPLING

Food and/or beverage products may be sampled without waiver fee, if the product being sampled is manufactured, produced and/or distributed by the exhibiting company. Sample sizes are as follows:

*Alcohol:*

Contact your Catering Sales Manager

*Food:*

Not more than 2 ounces

*Non-Alcoholic Beverages:*

Not more than 4 ounces

### STAFFING FEES

Booth Attendant (as requested or required)- \$150.00/4 hour minimum, \$37.50 each additional hour

Chef Attendant- \$150.00/4 hour minimum (unless specified "includes Chef Attendant" in Menu) \$37.50 each additional hour.

Staff fees based on hourly rates, a taxable 20% administrative fee and 7% sales tax, or 5% administrative fee, 15% gratuity, and 7% sales tax. Event type and size determines the fee structure.

Additional waitstaff can be added to your event. The charge will be based on the per person gratuity on the event, assessed based on the event type, size, and menu, as well as the hourly rate with a 4-hour minimum.

### SPACE REQUIREMENTS

Adequate table space will be provided by Levy in the case there is not existing or enough counter space in the booth, at no additional charge. Please take booth size into account while developing your menu. Where specialty equipment is utilized, please consult with your catering sales manager as they will be able to provide you with dimensions for your planning purposes.

### ELECTRICAL NEEDS

All electrical needs for food and beverage items are included with the catering orders. Please contact your general contractor to confirm adequate power is available for the food and beverage items. Any menus/items that require additional power are marked with an "\*\*E\*\*".

### DIETARY RESTRICTIONS

The following abbreviations are used throughout this menu: VEG (Vegetarian), VGN (Vegan), and AVG (Avoiding Gluten). Due to the open air nature of our kitchen we are unable to certify any items as being "Gluten Free" or free from all allergens (certain pre-packaged items excluded) as cross-contamination is a possibility. Should you need a dietary accommodation, please consult with your catering sales manager.



Remarkable experiences.  
Imagination realized.™



# SIGNATURE “NEW ENGLAND” BREAKFAST EXPERIENCE

*Breakfast is the most important meal of the day and we take that very seriously. From our freshly baked muffins and Revolutionary Morning scones to hearty hot morning favorites, we will make sure you start your day off right!*



# SIGNATURE “NEW ENGLAND” BREAKFAST EXPERIENCE

Our Signature spread of maple glazed morning buns, seasonal sliced fruit, orange and cranberry juices, and our Signature Reserve coffee and teas, serves up all of your breakfast must-haves.

25.00 PER GUEST - INCENTIVE

27.50 PER GUEST - STANDARD

*Enhance your breakfast experience by adding an array of toasty breakfast sandwiches, premium pastries, and top notch savory and sweet sides.*

## BREAKFAST SANDWICHES

INCENTIVE PRICING \*E

STANDARD PRICING \*E

Bacon, Egg, and Cheese on a Pretzel Roll

72.00 per dozen

79.50 per dozen

Ham, Egg, and Cheese on an English Muffin

Sausage, Egg White, and Cheese on a Croissant

Egg White, Spinach, and Cheese on a Whole Wheat Bagel (VEG)

Spicy Sausage, Egg, and Cheese Burrito

## FROM OUR BAKE SHOP

INCENTIVE PRICING

STANDARD PRICING

A Selection of Fresh Baked Muffins (VEG)

50.00 per dozen

55.00 per dozen

Assorted Bagels and Local Spreads (VEG)

Revolutionary Morning Scones (VEG)

Flaky Danish Pastry (VEG)

Plain and Filled Croissants (VEG)

## ENHANCEMENTS

INCENTIVE PRICING

STANDARD PRICING

Assorted Cereals (VEG)

60.00 per dozen

66.00 per dozen

Cranberry-Apricot Yogurt Parfaits featuring local bog cranberry and dried apricot compote, layered with vanilla yogurt, and topped with honey crunch granola (VEG)

60.00 per dozen

66.00 per dozen

Yogurt (Plain, Greek, Fruit, and Lowfat) (VEG, AVG)

60.00 per dozen

66.00 per dozen

Market Whole Fruit (VGN, AVG)

42.00 per dozen

46.00 per dozen

Seasonal Sliced Fresh Fruit Platter with strawberry yogurt sauce (VEG, AVG)

50.00 serves 10

55.00 serves 10

Prices are exclusive of a 15% gratuity, 5% taxable administrative fee and 7% applicable sales tax or a 20% taxable administrative fee and 7% applicable sales tax, as determined by our staffing guidelines. The gratuity is distributed to banquet employees. No other fees or charges including the administrative fee, represent tips, gratuities or service charges for any employees. Before placing your order, please inform your server if a person in your party has a food allergy. Menu prices are subject to change.

# NON-ALCOHOLIC REFRESHMENTS

*We offer a bevy of non-alcoholic beverages to quench your thirst. Bright, refreshing fruit waters showcase unexpectedly delicious flavor combinations like Cucumber-Lemon and Watermelon-Mint.*



## NON-ALCOHOLIC REFRESHMENTS

Customize your booth experience with the right beverage services from the options below.

	INCENTIVE PRICING	STANDARD PRICING
<b>SIGNATURE RESERVE COFFEE AND ASSORTED TEAS</b> Fresh brewed Signature Reserve coffee and hot tea	62.00 per gallon	68.00 per gallon
<b>WICKED GOOD HOT CHOCOLATE</b> Mini marshmallows, chocolate shavings, and whipped cream (3 gallon minimum)	62.00 per gallon	68.00 per gallon
<b>AQUAFINA BOTTLED WATER</b> Case of 24 - 16.9 oz. bottles	96.00 per case	105.00 per case
<b>ASSORTED PEPSI PRODUCTS</b> Case of 24 - 12 oz. cans	96.00 per case	105.00 per case
<b>POLAND SPRING SPARKLING WATER</b> Case of 24 - 16.9 oz. bottles	96.00 per case	105.00 per case
<b>INDIVIDUAL BOTTLED JUICE</b> Case of 24 - 15.2 oz. bottles	108.00 per case	120.00 per case
<b>ALL NATURAL SPA WATER</b> Refreshing still water with fruit (not blended) (3 gallon minimum per flavor)	59.00 per gallon	65.00 per gallon
<b>ALL NATURAL FRUIT INFUSED WATER</b> Watermelon-Mint, Cucumber-Lemon, Cranberry-Lime, Ginger-Orange, and Apple-Rosemary (3 gallon minimum per flavor)	59.00 per gallon	65.00 per gallon
<b>BLENDED ICED TEA AND LEMONADE</b> Strawberry, Cranberry-Lime, Blueberry, Classic Iced Tea, and Classic Lemonade (3 gallon minimum per flavor)	48.00 per gallon	53.00 per gallon
<b>KEURIG COFFEE MACHINE</b> Includes all accoutrements to make a cup of coffee. K-Cups not included. *E	85.00 per day	93.50 per day
<b>K-CUPS (BOX OF 24)</b> Select from the following: Green Mountain House Blend, Decaf House Blend, French Vanilla, Hazelnut, and Celestial Decaf Green Tea	54.00 per case	59.50 per case
<b>WATER COOLER RENTAL</b> *E	75.00 per day	83.00 per day
<b>5-GALLON WATER JUG</b>	35.00 each	38.50 each

Prices are exclusive of a 15% gratuity, 5% taxable administrative fee and 7% applicable sales tax or a 20% taxable administrative fee and 7% applicable sales tax, as determined by our staffing guidelines. The gratuity is distributed to banquet employees. No other fees or charges including the administrative fee, represent tips, gratuities or service charges for any employees. Before placing your order, please inform your server if a person in your party has a food allergy. Menu prices are subject to change.

## THE SWEET...

Savory, sweet and everything in between! Craft the perfect snack break with one or more of our delectable menus below.

	INCENTIVE PRICING	STANDARD PRICING
<b>CANDYLAND OF NEW ENGLAND</b> Salt Water Taffy, Boston Baked Beans, Boardwalk Fudge, Mary Janes, Toffee, Old Fashioned Candy Sticks, Charleston Chews, Licorice, Yogurt Dipped current and nostalgic favorites (VEG)	<i>225.00 serves 25</i>	<i>132.00 serves 25</i>
<b>WHOOPIE PIES</b> Chocolate, carrot cake, and red velvet (VEG)	<i>36.00 per dozen</i>	<i>40.00 per dozen</i>
<b>GOURMET CUPCAKE BAR</b> A variety of flavors including lemon meringue, red velvet, chocolate, peanut butter cup, jelly roll, double chocolate, and vanilla bean (VEG)	<i>57.00 per dozen</i>	<i>63.00 per dozen</i>
<b>RICE KRISPIE TREATS</b> Classic, hand-dipped chocolate, and peanut butter (VEG)	<i>39.00 per dozen</i>	<i>43.00 per dozen</i>
<b>BCEC COOKIES (JUMBO) (VEG)</b>	<i>41.00 per dozen</i>	<i>45.00 per dozen</i>
<b>HYNES COOKIES (VEG)</b> A smaller version of our freshly baked cookie	<i>29.00 per dozen</i>	<i>32.00 per dozen</i>
<b>MACARON MADNESS</b> Vanilla, pistachio, coffee, raspberry, lemon, and chocolate (VEG)	<i>38.00 per dozen</i>	<i>42.00 per dozen</i>
<b>GOURMET BROWNIES</b> Espresso, chocolate chunk, turtle, and fudge (VEG)	<i>41.00 per dozen</i>	<i>45.00 per dozen</i>
<b>HERSHEY KISSES</b> 3 pound minimum (VEG, AVG)	<i>12.00 per pound</i>	<i>14.00 per pound</i>
<b>CHOCOLATE COVERED STRAWBERRIES (VEG, AVG)</b> 3 dozen minimum	<i>45.00 per dozen</i>	<i>50.00 per dozen</i>
<b>BULK CANDY</b> 3 pound minimum (VEG) Ask your catering sales manager for details	<i>20.00 per pound</i>	<i>22.00 per pound</i>
<b>CANDY BARS (VEG)</b> 3 dozen minimum	<i>36.00 per dozen</i>	<i>40.00 per dozen</i>

Prices are exclusive of a 15% gratuity, 5% taxable administrative fee and 7% applicable sales tax or a 20% taxable administrative fee and 7% applicable sales tax, as determined by our staffing guidelines. The gratuity is distributed to banquet employees. No other fees or charges including the administrative fee, represent tips, gratuities or service charges for any employees. Before placing your order, please inform your server if a person in your party has a food allergy. Menu prices are subject to change.

## AND THE SAVORY

Savory, sweet and everything in between. Craft the perfect snack break with one or more of our delectable menus below.

INCENTIVE PRICING | STANDARD PRICING

### ARTISANAL BAVARIAN PRETZEL

*Our signature snack, hand-rolled in-house, and served warm with delicious accompaniments.*

Traditional Salted Bavarian with Brown Mustard (VEG)

Chipotle and Yellow Mustard with warm Sam Adams Boston Lager Cheese (VEG)

Cinnamon Sugar with Vanilla Bean Sauce (VEG)

*Minimum of 3 dozen, per flavor \*E*

108.00 | 119.00 | PER DOZEN

### POTATO CHIPS AND GOURMET DIPS

Kettle-style potato chips with roasted garlic Parmesan, French onion, and blue cheese dips (VEG, AVG)

51.00 | 56.00 | SERVES 12

### FARMSTEAD CHEESE DISPLAY

Chef's selection of local and imported cheeses with flavored honey, fresh seasonal berries, dried fruit garnish, artisan breads, and crackers (VEG)

225.00 | 248.00 | SERVES 25

### HUMMUS TRIO

Traditional chickpea, white bean, and edamame hummus, served with crispy carrots, celery, crackers, and pita chips (VEG)

210.00 | 231.00 | SERVES 25

### ENERGY MIX

Pre-packaged assortment of dried papaya, yogurt coated raisins, roasted almonds, roasted peanuts, dried cranberries, chocolate chunks, and banana chips (VEG)

9.00 | 10.00 | EACH

### ASSORTED SNACKS

Garden Fresh Crudités with buttermilk-ranch dipping sauce (VEG, AVG)

*55.00 | 60.00 serves 10*

Deluxe Mixed Nuts (AVG)

*18.00 | 20.00 | per pound*

Assorted Granola Bars (VEG)

*36.00 | 40.00 | per dozen*

Assorted Energy Bars (VEG)

*55.00 | 60.00 | per dozen*

Assorted individual bags of potato chips including Cape Cod Chips, Stacy's Pita Chips, Smartfood Popcorn and Pop Chips (VGN, AVG)

*39.00 | 43.00 | per dozen*

# CHEF'S BEST BOX LUNCH

*These lunches, expertly crafted by our culinary team, are chef-tested and guest approved. Our boxed lunches deliver luscious local flavors, high quality ingredients, and easily customized offerings that will please even the most particular palates.*



# CHEF'S BEST BOX LUNCH

A great option for the grab and go lunch!

INCENTIVE PRICING | STANDARD PRICING

## BOX LUNCHES

*Smokin' Gobbler* with applewood smoked turkey, sharp smoked cheddar cheese, cranberry-apricot chutney, and sage aioli, on a honey wheat hoagie roll

32.00 each | 35.00 each

*Roast Beef and Arugula* with Gruyere, caramelized onions, and horseradish sauce

32.00 each | 35.00 each

*Tuscan Chicken* with grilled herb marinated chicken, oven-dried tomatoes, balsamic onions, and provolone, on herb focaccia with pesto aioli

32.00 each | 35.00 each

*Shaved Cured Ham and Baby Swiss* with honey-country dijon mustard, on a pretzel roll

32.00 each | 35.00 each

*"ZLT" Flatbread Sandwich* with grilled zucchini, tomatoes, jalapeño jack cheese, and sun-dried tomato pesto (VEG)

32.00 each | 35.00 each

*Italian Chopped Salad* with grilled chicken, crispy bacon, romaine, radicchio, tomatoes, red onions, ditalini, and crumbled blue cheese, with honey dijon vinaigrette

32.00 each | 35.00 each

## EACH LUNCH INCLUDES:

Aquafina Water

Whole Fresh Fruit (VGN, AVG)

Bag of Cape Cod Chips (VGN, AVG)

Giant Chocolate Chip Cookie (VEG)

Prices are exclusive of a 15% gratuity, 5% taxable administrative fee and 7% applicable sales tax or a 20% taxable administrative fee and 7% applicable sales tax, as determined by our staffing guidelines. The gratuity is distributed to banquet employees. No other fees or charges including the administrative fee, represent tips, gratuities or service charges for any employees. Before placing your order, please inform your server if a person in your party has a food allergy. Menu prices are subject to change.

# RECEPTION HORS D'OEUVRES

***50 piece minimum per item***

**INCENTIVE PRICING | STANDARD PRICING**



## ***New England Specialties***

Slow-Cooked Boston Baked Beans with caramelized onions and brown bread \*E  
(VEG) *3.25 each | 3.75 each*

Individual Yankee Pot Roast with braised beef tips, sweet peas, carrots, and potatoes, topped with a mini buttermilk herb biscuit \*E *4.25 each | 4.75 each*

BBQ Oyster with charred corn, smoky bacon, and citrus aioli (AVG)  
*5.00 each | 5.50 each*

Mini Lobster Rolls on grilled brioche  
*7.00 each | 7.75 each*

“Soup Sip” Clam Chowder \*E  
*4.00 each | 4.50 each*

## ***Retro Minis - Classic Favorites!***

Beef Wellington Bites with horseradish cream \*E *4.00 each | 4.25 each*

Frank ‘n Blanket featuring cocktail sausage and flaky puff pastry \*E  
*4.25 each | 4.50 each*

Chicken Cordon Blue with smoked ham and blue cheese sauce \*E  
*3.25 each | 3.75 each*

## ***Grilled Artisan Bread Crostini***

Tomato-Basil with artisan olive oil (VEG)  
*4.25 each | 4.75 each*

Whipped Ricotta with olive salad (VEG)  
*4.25 each | 4.75 each*

Beef Carpaccio with garlic aioli and Parmesan *4.25 each | 4.75 each*

## ***Quesadillas***

House-Smoked Brisket and Cheddar Cheese with avocado crema \*E  
*4.50 each | 5.00 each*

Ancho Chicken and Jack Cheese with salsa verde \*E *4.50 each | 5.00 each*

Fire-Roasted Vegetable with pico de gallo (VEG) \*E *4.50 each | 5.00 each*

## ***Hand Crafted Mini Sliders***

Slow-Roasted Prime Rib with smoked cheddar, caramelized onions, and BBQ sauce \*E *5.50 each | 6.00 each*

Breaded Chicken Parmesan with marinara and fresh mozzarella \*E  
*5.50 each | 6.00 each*

Homemade Meatloaf with crispy onions and sautéed wild mushrooms \*E  
*5.50 each | 6.00 each*

Prices are exclusive of a 15% gratuity, 5% taxable administrative fee and 7% applicable sales tax or a 20% taxable administrative fee and 7% applicable sales tax, as determined by our staffing guidelines. The gratuity is distributed to banquet employees. No other fees or charges including the administrative fee, represent tips, gratuities or service charges for any employees. Before placing your order, please inform your server if a person in your party has a food allergy. Menu prices are subject to change.

**Mini Chilled Shrimp Shooters**

Classic Fisherman's Wharf-Style with horseradish cocktail sauce (AVG)  
*6.50 each | 7.00 each*

Bayou-Blackened with remoulade sauce (AVG) *6.50 each | 7.00 each*

Pesto-Marinated with lemon aioli (AVG)  
*6.50 each | 7.00 each*

**Sumptuous Satays**

Thai Peanut Ginger Chicken with sweet chili sauce \*E *5.25 each | 5.75 each*

Sizzling Short Rib with Thai peanut sauce \*E  
*5.50 each | 6.00 each*

Basil-Garlic Shrimp with chili lime mint sauce \*E *5.50 each | 6.00 each*

**Flatbreads and Flatinis**

Fig and Blue Cheese Flatbread with sweet imported fig preserves, creamy blue cheese, and green onions (VEG) \*E  
*4.75 each | 5.25 each*

Chicken Pesto Flatbread with fresh pesto, diced chicken, tender artichoke hearts, sun-dried tomatoes, and asiago cheese \*E  
*4.75 each | 5.25 each*

Mini Reuben Flatini with corned beef, sauerkraut, and swiss cheese, on a lightly toasted flatbread \*E  
*4.75 each | 5.25 each*

# SMALL BITES RECEPTION



# SMALL BITES RECEPTION

Enhance the draw to your corner of the world with some delightful morsels below.

INCENTIVE PRICING | STANDARD PRICING

## ARTISANAL CHARCUTERIE

Imported Cured Meats and Cheeses  
Local Seasonal Vegetables  
Marinated Olives  
Flatbreads, Crostini, and Breadsticks

275.00 | 303.00 | SERVES 25

## GOURMET FOCACCIA

*A fun assortment of artisan grilled focaccia bread with a selection of toppings, served hot.*

Fennel Sausage with wild mushroom and Asiago cheese  
Classic Clam Sauce and farmer's cheese  
Roma Tomatoes with basil and fresh mozzarella (VEG)  
Pulled Chicken with cilantro-pesto and four cheeses

235.00 | 255.00 | SERVES 25

## MAC-N-CHEESE MADNESS

*Classic comfort food, kicked up a notch!*

Buffalo Chicken with Jack and blue cheese  
Smoked Pork with green chiles and cheddar  
Cheetos-Crusted (VEG)  
Chorizo and Jack Cheese with tortilla crust  
White Cheese with spinach and artichokes (VEG)  
Smoked Cheddar with BBQ potato chip crust (VEG)

*Select up to 3*

360.00 | 390.00 | SERVES 50 \*E

## MASHED POTATO BAR

*Old fashioned, creamy mashed potatoes with specialty ingredients.*

Lobster Mashed Potatoes (AVG)  
Yukon Gold Mashed Potatoes and Braised Short Ribs with a cabernet reduction (AVG)  
Sweet Mashed Potatoes with cinnamon, brown sugar, butter, and candied pecans (VEG, AVG)

285.00 | 314.00 | SERVES 25 \*E

# FOOD & BEVERAGE PAIRING PACKAGES

*Select a unique culinary pairing for your guests to enjoy at your booth. A locally inspired option is sure to be a conversation starter!*



# FOOD & BEVERAGE PAIRING PACKAGES

Entice your guests with expertly crafted pairings.

Whether you prefer spirits, fine wine, or malted options, we can offer you the perfect food combination to enhance your guests' experience.

*All pricing is based on 150 guests (minimum) unless otherwise noted Bartender Required, Additional Fees Apply.*

## REVOLUTIONARY RESERVES

*Meiomi Sonoma- Monterey, Santa Barbara, California, Pinot Noir*

Fig and Blue Cheese Flatbread with sweet imported fig preserves, creamy blue cheese, and green onions (VEG) **3,075.00**

*Kim Crawford, Marlborough, New Zealand, Sauvignon Blanc*

Signature Crab Cake with lemon aioli **2,850.00**

*Boston Winery, California, Cabernet Sauvignon*

Bayou Blackened Shrimp Shooter with remoulade sauce (AVG) **2,520.00**

*Kim Crawford, Marlborough, New Zealand, Sauvignon Blanc*

Mini Caramelized Onion Tartines with goat cheese fondue and balsamic crème (VEG) **2,440.00**

## PATRIOTIC PAIRINGS

*La Crema, Monterey, California, Chardonnay*

Pulled Chicken Focaccia with cilantro-pesto & four cheeses **2,595.00**

*14 Hands, Washington, Merlot*

Sizzling Short Rib Satay with Thai peanut sauce **1,950.00**

*Alamos, Mendoza, Argentina, Malbec*

Roasted Wild Mushroom Bruschetta with gorgonzola cheese (VEG) **1,695.00**

*Alamos, Mendoza, Argentina, Malbec*

Beef Carpaccio Crostini with garlic aioli and parmesan **1,695.00**

## COLONIAL COLLECTIONS

*Sam Adams Seasonal Brew*

Sam Adams Beer Battered "Fish & Chips" with mini salt and vinegar pub chips, and classic tartar sauce **1,875.00**

*Sam Adams Boston Lager*

Mini Reuben Flatini with corned beef, sauerkraut, and Swiss cheese on a lightly toasted flatbread **1,650.00**

*Sam Adams Boston Lager*

Gourmet Focaccia with fennel sausage, mushrooms, and asiago cheese **1,650.00**

*Harpoon IPA*

Mini Pretzel Bites with beer cheese dip (VEG) **1,650.00**

## WICKED AWESOME LOCAL PAIRINGS

*Pricing for the below is based on a minimum of 50 guests*

### BOSTON HARBOR DISTILLERY

*Lawley's Original and Lawley's Dark New England Spirits, Cranberry Juice, Orange Juice, Seltzer, Turbinado Syrup, & Fresh Lime*  
New England Clam Cakes with lemon aioli **700.00**

### SAILOR'S REMEDY

*Irish Whiskey and Downeast Cider*  
Parmesan Stuffed Peppadew with goat cheese and fine herbs (VEG) **700.00**

### SUN SPLASH

*Triple Sec, Cranberry Vodka, Cranberry Juice, Lime Juice, Lemon-Lime Soda*  
Maine Bay Shrimp Sope with avocado and cotija cheese (AVG) **700.00**

### SPICED APPLE

*Fireball Whiskey and Downeast Cider*  
Bacon Jam Tart with Great Hill blue cheese **675.00**

Prices are exclusive of a 15% gratuity, 5% taxable administrative fee and 7% applicable sales tax or a 20% taxable administrative fee and 7% applicable sales tax, as determined by our staffing guidelines. The gratuity is distributed to banquet employees. No other fees or charges including the administrative fee, represent tips, gratuities or service charges for any employees. Before placing your order, please inform your server if a person in your party has a food allergy. Menu prices are subject to change.

# TRAFFIC BUILDERS

INCENTIVE PRICING | STANDARD PRICING



## NEW ENGLAND NUT ROASTER

*With rotating flavors throughout the day, the tantalizing aromas are sure to lead guests to your booth. Chef attendant included. \*E*

*Approximately 350 (.75oz/servings)*

*Flavors:*

*Apple Pie Cashews*

*Curried Coconut Macadamia Nuts*

*Snickerdoodle Walnuts*

*(VEG)*

1,450.00 | 1,595.00

## CHOCOLATE GYRO STATION

*A chef attendant will freshly prepare and fill crepes with delicate fillings like Banana Compote or Nutella and Marshmallow Fluff. Atop the crepe, swirled milk and white Belgian chocolate will be shaved from the rotating spit; sure to be the talk of the show! Chef attendant included. \*E*

*Approximately (240 servings)*

*Attendant included and is required. \*E*

*Flavors:*

*Roasted Banana Compote*

*Nutella and Marshmallow Fluff*

*(VEG)*

1,450.00 | 1,595.00

## ANTI-GRIDDLE FROZEN LOLLIPOPS

Feel the chill from a 30° below zero anti-griddle, and watch as our chef prepares frozen lollipop treats. You'll be the coolest exhibitor on the floor. Chef attendant included. \*E

(240 servings)

Flavors:

Apple Butter and Bacon (80 each)

Chocolate-Nutella (80 each)

Mixed Berry (80 each)

(VEG, AVG)

1,450.00 | 1,595.00

## WALKING WAFFLE BITES

"Small Bites" waffles on a stick drizzled with white and dark chocolate, cinnamon and sugar, or "all natural", these conversation novelties will have attendees directing their colleagues to your booth in short order. Chef attendant included. \*E

(240 servings)

Flavors:

Red Velvet

Mocha

Cinnamon Roll

Assorted toppings included

(VEG)

1,200.00 | 1,320.00

## STROLLING HYDRATION STATION

A flat bottomed juice bag filled with your selection of all natural juices, flavored waters and teas. Chef attendant included.

(240 servings)

Ask about our branding opportunities

Flavors:

Blueberry-Lemonade Cheesecake

Green Tea with Chai

Apple-Rosemary

1,200.00 | 1,320.00

## CHAMPOPSICLE COCKTAIL

Stop traffic with this original looking cocktail boasting an upside down Chloe Pop placed in a stemless wine glass of champagne. Your choice of banana, mango, raspberry, strawberry, or tangerine. Pick a flavor/color to compliment your branding and bring your show to life.

(120 servings) Bartender fee not included.

Requires space for included table top freezer.

(VGN)

1,615.00 | 1,776.50

Prices are exclusive of a 15% gratuity, 5% taxable administrative fee and 7% applicable sales tax or a 20% taxable administrative fee and 7% applicable sales tax, as determined by our staffing guidelines. The gratuity is distributed to banquet employees. No other fees or charges including the administrative fee, represent tips, gratuities or service charges for any employees. Before placing your order, please inform your server if a person in your party has a food allergy. Menu prices are subject to change.

# TRAFFIC BUILDERS

## *continued*

INCENTIVE PRICING | STANDARD PRICING



### COTTON CANDY ACTION STATION

*Entice attendees with the smell of sweet cotton candy being freshly spun on the show floor. Can be served in the traditional fashion on a paper cone or bagged for a more conservative option. A variety of flavors and colors are available. \*E*

*Note only (1) color per machine.*

*(250 servings) Attendant included.*

(VGN, AVG)

2,100.00 | 2,310.00

### CHOCOLATE CHIP COOKIE STOP

*Cookie oven includes: one case of 240 cookies, napkins, plates, and serving platter. Additional cases of cookies are 480.00 each. \*E*

*Attendant included.*

(VEG)

630.00 PER CASE | 680.00 PER CASE

### ICE CREAM BARS

*Ice Cream Cooler includes: 10 dozen assorted ice cream bars and napkins. \*E*

*Attendant included.*

(VEG)

630.00 | 680.00

### CAMPFIRE S'MORES PACKAGE

*On-stage roasted marshmallow sandwich with milk chocolate and graham crackers. \*E*

*(250 Servings) Attendant included.*

(VEG)

2,000 | 2,500

## CHLOE'S FRUIT POPS

*10 dozen assorted popsicles*

*Flavors:*

*Mango, Strawberry, Chocolate, and  
Raspberry \*E*

*Requires space for included table top freezer.*

(VGN)

690.00 | 760.00

## BEN & JERRY'S FLAVORS

*10 dozen assorted 4 oz. ice cream cups*

*Flavors:*

*Chocolate Chip Cookie Dough, Chocolate  
Fudge Brownie, Cherry Garcia, Strawberry  
Cheesecake, and Americone Dream  
(Vanilla Ice Cream with Fudge Covered  
Waffle Cone Pieces & Caramel Swirl) \*E*

*Requires space for included table top freezer.*

(VEG)

810.00 | 890.00

# TRAFFIC BUILDERS

*continued*



## MARKEY LTD ESPRESSO SERVICE

*Our Baristi are fully trained to get the most from our state-of-the-art espresso machines. The friendly crew will ensure your guests have a memorable visit, featuring drinks that you would see in any world-class espresso bar including: Cappucinos, Lattes, Americanos, Espressos, and all the other favorites, as well as herbal teas and hot chocolate.*

*Price per day includes up to 1500 servings (combination of 8 oz. cups for coffees and teas & 4 oz. cups for espressos), two trained staff to serve, counter, all equipment, consumables, stock, water and electrical supply.*

**Power Requirements:**

*Coffee machine: 5kW, 30 Amp at 208 volts*

*Grinder: 350W, 5 Amp at 110 volts*

*Refrigerator: 10 Amp at 115 volts*

**3,200.00 PER DAY**



## MARKEY LTD VEGETABLE & FRUIT JUICE BAR

*Two trained Baristi will press fresh and seasonal, locally sourced fruits and vegetables, to produce the most natural of juices. Our menu is designed with nutritional values, taste, and color in mind.*

**Flavors:**

*Orlando Orange: Carrot, Apple, Ginger, and Orange Juice*

*Green Goddess: Celery, Cucumber, Spinach, Apple, and Lemon*

*Pink Lady: Apple, Pineapple, and Beetroot*

*Price per day includes up to 500 servings (8 oz. cups), two trained staff to serve, counter, all equipment, consumables, stock, water and electrical supply. Additional orders may be added up to 1 week ahead of the first show day with a minimum of 100 servings at 5.00 each.*

**Power Requirements:**

*Juice machines: 3 x 20 Amp at 110 volts (usually three machines are running)*

*Refrigerator: 2x10 Amp at 115 volts*

**3,400.00 PER DAY**

## MARKEY LTD ITALIAN GELATO BAR

*Two trained staff members to scoop and serve various flavors of gelato with an array of flavors from which to choose. A perfect attraction to your booth. Our menu includes intensely delicious dairy-free sorbets and creamy gelati.*

**Flavors:**

*Chocolate, Pistachio, Vanilla Bean, Dolce de Leche, Raspberry, and Lemon.*

*Our gelato freezer can display up to 6 flavors*

*Price per day includes up to 500 servings (5 oz. cups), two trained staff to serve, gelato display cabinet, all equipment, consumables, stock and electrical supply. Additional orders may be added on show day with a minimum order of 100 servings at 5.00 each.*

**Power Requirements:**

*Gelato cabinet: 3 kW, single phase, 15 Amp at 110 volts. A 24 hour power supply is required for the gelato cabinet.*

**3,400.00 PER DAY**

# TRAFFIC BUILDERS

*continued*



## MARKEY LTD SMOOTHIE BAR

*Two trained baristas will cut, shake, stir, and blend an exciting menu. Fresh fruit and natural fruit puree ingredients will be combined to create colorful and exceptional flavors.*

**Flavors:**

*Fantastic 5: Blueberry, Blackberry, Strawberry, and Raspberry with Cranberry juice*

*Tropic Passion: Mango, Passion Fruit, and Watermelon with Orange Juice & Coconut Water*

*Zinger: Strawberry, Banana, Lime Juice, and Mint with Apple Juice*

*Pinkie Deluxe: Strawberry & Cherry with Low-Fat Natural Yogurt*

*Price per day includes up to 500 servings (8 oz. cups), two trained staff to serve, counter, all equipment, consumables, stock and electrical supply. Additional orders may be added on show day with a minimum order of 100 servings at 5.00 each.*

**Power Requirements:**

*Blenders: 4 x 13 Amp at 110 volts*

*Refrigerator: 10 Amp at 115 volts*

**3,400.00 PER DAY**

## MARKEY LTD FROZEN YOGURT OR SOFT SERVE ICE CREAM BAR

*Two trained staff members to serve and garnish our popular Frozen Yogurt or Soft Serve Ice Cream Bar.*

**Flavors:**

*Frozen Yogurt Flavors: Non-Fat or Natural Tart base*

*Soft Serve Ice Cream: Vanilla*

*Toppings for Both: Strawberries, Blueberries, Pineapple, Granola, Milk Chocolate Chips, Sliced Almonds, Coconut, Caramel, and Honey*

*Price per day includes up to 500 servings (5 oz. cups), two trained staff to serve, counter, all equipment, consumables, stock and electrical supply. Additional orders may be added on show day with a minimum order of 100 servings at 5.00 each.*

**Power Requirements:**

*Frozen Yogurt/Soft Serve machine: 3 kW, single phase, 20 Amp at 110 volts*

*Refrigerator: 10 Amp at 115 volts*

**3,400.00 PER DAY**

Prices are exclusive of a 15% gratuity, 5% taxable administrative fee and 7% applicable sales tax or a 20% taxable administrative fee and 7% applicable sales tax, as determined by our staffing guidelines. The gratuity is distributed to banquet employees. No other fees or charges including the administrative fee, represent tips, gratuities or service charges for any employees. Before placing your order, please inform your server if a person in your party has a food allergy. Menu prices are subject to change.



## CHOCOLATE THERAPY SWEET REMEDIES

Based in Framingham, Chocolate Therapy makes a healthy indulgence that people can feel good about. The company's line of award-winning, antioxidant-rich truffles, caramel and more feature surprising flavor combinations and layers of flavors infused with therapeutic, local ingredients, such as olive oil, cinnamon, lavender, green tea, blueberries and more. These ingredients do everything from help to prevent heart disease, reduce stress or simply soothe the soul. Boxed sets also available. Please speak with your catering manager for additional options.

### *Year-Round Dark Chocolate Truffles* 3.75 per piece

- CStress Reliever (honey, lavender & sage)
- Grand Marnier
- Blueberry Lemon Basil
- Dark Chocolate with olive oil & sea salt
- Strawberry Balsamic
- The Cure (cayenne, cinnamon & bay leaf)
- Pistachio
- Lemon Lavender
- Earl Greyer (earl grey tea with bergamot)
- Pom Bom

### *Dairy-Free* 3.75 per piece

- Castaway (sesame seeds & coconut oil)
- Dark Chocolate Hazelnut
- Black Coffee (made with soy milk)

### *Custom Chocolate Bar with Logo*

Choice of dark chocolate or milk chocolate,  
*note that pricing does not include 275.00 fee  
for reusable silicon molds*  
**10.00 each**

No minimums. Box substitutions available to suit individual preferences and diets, including dairy-free and sugar-free. Add 4.00 more for gift packaging and/or 2.00 more for ribbon. Custom logo chocolates (transfer sheet on top) also available for an additional setup fee.



CHOCOLATE THERAPY  
*sweet remedies*

# BAR SELECTIONS

*Catch up with your guests over an expertly crafted cocktail, mixed to perfection by our bar staff. In addition to premium liquor, amp up your bar package with wine and imported and domestic beers.*



## BAR SELECTIONS

Beverages are billed on consumption unless otherwise noted. Levy bartender(s) required and bartender fees apply. Cash bar options are available.

### HOSTED DELUXE BAR

#### COCKTAILS

Featuring Tito's Handmade Vodka, Aviation Gin, Maker's Mark, Dewar's 12, Bacardi Superior, Uncle Nearest Premium Tennessee Whiskey, Milagro Tequila, Glenfiddich 12, Martini & Rossi Dry and Sweet Vermouth  
*8.00 per drink*

#### WINE BY THE GLASS

La Crema Chardonnay  
*8.00 per glass*

Louis Martini Cabernet Sauvignon  
*8.00 per glass*

Mark West Pinot Noir  
*8.00 per glass*

Markham Sauvignon Blanc  
*8.00 per glass*

#### SPARKLING

Ruffino Prosecco  
*8.00 per glass*

**IMPORTED/  
PREMIUM BEER** *6.50 each*

**DOMESTIC BEER** *6.25 each*

**BOTTLED WATER** *4.00 each*

**SOFT DRINKS** *4.00 each*

**JUICES** *4.75 each*

### HOSTED PREMIUM BAR

#### COCKTAILS

Featuring Svedka Vodka, Beefeater Gin, Jim Beam, Dewar's White Label, Bacardi Superior, Jack Daniel's, El Jimador Tequila, Martini & Rossi Dry and Sweet Vermouth  
*7.00 per drink*

#### WINES BY THE GLASS

*Woodbridge by Robert Mondavi*

Pinot Grigio  
*7.00 per glass*

Chardonnay  
*7.00 per glass*

Merlot  
*7.00 per glass*

Cabernet Sauvignon  
*7.00 per glass*

#### SPARKLING

Ruffino Prosecco  
*8.00 per glass*

**IMPORTED/  
PREMIUM BEER** *6.50 each*

**DOMESTIC BEER** *6.25 each*

**BOTTLED WATER** *4.00 each*

**SOFT DRINKS** *4.00 each*

**JUICES** *4.75 each*

## EXHIBITOR CATERING ORDER FORM

### EXHIBITING COMPANY INFORMATION

Company Name <i>(Include Booth Name if Different):</i>			
Billing Address:			
City, State, Zip Code:			Country:
Main Telephone Number:			
Main Fax Number:			
Email Address:			

### SITE INFORMATION

Event Name:			
Booth Number:			Booth Size:
On-Site Contact Name:			
On-Site Contact Cell Number:			

	DELIVERY TIME/ SERVICE END TIME	ITEM DESCRIPTION	QTY	

*Prices are exclusive of a 15% gratuity, 5% taxable administrative fee and 7% applicable sales tax or a 20% taxable administrative fee and 7% applicable sales tax, as determined by our staffing guidelines. The gratuity is distributed to banquet employees.  
No other fees or charges, including the administrative fee, represent tips, gratuities or service charges for any employees.*

This letter serves as my formal written authorization and approval for you to charge the credit card indicated below for any and all charges related to food services at the BCEC. This letter shall constitute my express written permission for you to charge, to the extent not previously paid for, the credit card for the initial deposit, the balance due before and any charges incurred during the event.

### CREDIT CARD AUTHORIZATION

Card Type: <input type="checkbox"/> Visa <input type="checkbox"/> MC <input type="checkbox"/> AMEX <input type="checkbox"/> Discover	Billing Zip Code:
Credit Card Number:	Exp Date:
Signature of Card Holder:	Name as appears on Card:

Mail, or Scan (Along With Any Floor Plans) To:  
**Eiman Karim – Catering Sales Manager**  
 Levy Restaurants | Boston Convention & Exhibition Center  
 Phone: 617.954.2320  
 Email: [ekarim@levyrestaurants.com](mailto:ekarim@levyrestaurants.com)

# Exhibitor Ordering Guide

BOSTON CONVENTION & EXHIBITION CENTER

JANUARY 1, 2019 - DECEMBER 31, 2019

Prepared Exclusively for:



Biotechnology  
Industry  
Organization



*Signature*  
**BOSTON™**

Remarkable experiences.  
Imagination realized.™

## **TABLE OF CONTENTS**

Introduction	1
General Information	2
Electrical Services	3
Telephone Services	6
Internet & Technical Services	8
Rigging Services	12
Plumbing Services	17
Security Services	20
Appendix – Service Order Forms	21
Appendix – Exhibitor Guidelines, Information and Regulations	30
Appendix – Levy Restaurants Sample Food and/or Beverage Distribution Request	41



# Introduction

## **On behalf of the Massachusetts Convention Center Authority, welcome to Boston!**

We are excited to have you exhibit at our state-of-the-art facilities and look forward to working together to help you achieve your most ambitious goals. We are proud to offer the service, technology, and resources that will help you bring your vision to life. Our Exhibitor Services Team is an invaluable resource to assist you with transforming your ideas into an unforgettable event for your guests.

World-class customer service has become our signature as a meetings destination, which is why we have given our meetings and conventions experience a new name: Signature Boston. Unique and personal, a signature represents a promise that defines who we are and what we stand for. It speaks to our unwavering commitment to making every event we host in our city a success beyond your expectations.

This Ordering Guide is designed to make planning and ordering easy for all exhibitors. Each service section contains the following:

- Description of Services & Equipment and Pricing;
- Installation & Connection Information;
- Terms & Conditions, and;
- Frequently Asked Questions.

In addition to the orderable services listed in this guide, the MCCA also offers the following services for you to take advantage of on-site:

- Exhibitor Service Desk with assigned Event Associate
- Internet Support Services
- Free Wireless Internet Service
- FedEx Business Center

If you have any unanswered questions, please contact Exhibitor Services at 1.617.954.2230 or [exhibitorservices@SignatureBoston.com](mailto:exhibitorservices@SignatureBoston.com), and we will be happy to assist you!

# General Information

## ORDERING POLICIES & PROCEDURES

### Pricing

Discount, Standard and On-Site rates are available for most services. To qualify for the discount rate, order requests and payment must be received 21 days prior to the show opening. Standard rates will apply to orders received after this discount cut-off date and be effective through the before move-in begins. On-site rates will apply to orders received once move in has begun.

### Ordering

Exhibitors are encouraged to submit orders online at our secure and easy-to-use website, [www.SignatureBoston.com](http://www.SignatureBoston.com). Credit card payment is required for all online orders. Exhibitors who prefer to mail in their orders and pay by check will find our Service Order Forms in the Appendix of this guide. No telephone orders will be accepted.

### Exhibitors should be aware of the following when placing orders:

- All payments must be in US currency;
- The date payment is received determines the applicable rate (see Pricing above);
- Incomplete order or payment information will delay processing;
- Booth number(s) must be identified on all order forms.

### Payments

Payment for services must be received in advance. Service will be delivered only after payment is received. All outstanding charges must be paid before the close of the show. Please note that there will be no additional taxes added to service charges.

### Refunds

Claims for refunds must be submitted by the exhibitor to Exhibitor Services prior to event close. Credit will not be given for services installed and not used. Refunds are issued in the same manner in which payment was received.

### General Terms & Conditions

- All booth number changes must be communicated by the exhibitor to Exhibitor Services prior to exhibitor move-in. Additional charges may result, if services must be moved after initial set-up.
- All equipment and material furnished by the MCCA shall remain the property of the MCCA and shall be removed only by MCCA personnel.
- Standard wall outlets and other permanent building outlets (e.g., electrical, telephone, plumbing, etc.) are not part of the booth space and may not be used by anyone other than MCCA personnel or designated service provider.
- Service connections must be made by MCCA personnel or designated service provider.
- Connection services generally cover the installation of service to the booth area in the most convenient manner to the MCCA.
- All equipment must comply with state and local safety codes. MCCA will refuse connection to any equipment that constitutes a safety hazard.
- Unless otherwise directed, MCCA personnel are authorized to cut floor coverings to permit installation of services.

# Electrical Services

The MCCA offers a variety of electrical services through our experienced in-house team of electricians.

SPECIAL CONNECTIONS (208 VOLT & 480 VOLT POWER)	DISCOUNT	STANDARD	ON-SITE
Unless otherwise indicated in parentheses ( ), all special power connections will be hard-wire connected. To order Three Phase 100 amp service and higher, please contact MCCA exhibitor services for availability.			
208v single phase 30 amp (nema l21-30p)	\$360.00	\$450.00	\$540.00
208v single phase 60 amp	\$685.00	\$855.00	\$1,025.00
208v single phase 100 amp	\$1,050.00	\$1,310.00	\$1,575.00
208v three phase 30 amp (nema l21-30p)	\$650.00	\$810.00	\$975.00
208v three phase 60 amp	\$980.00	\$1,225.00	\$1,470.00
<b>Note: Any 100+ amp connection must be approved by MCCA Exhibitor Services. Please call 617.954.2230.</b>			
208v three phase 100 amp	\$1,555.00	\$1,945.00	\$2,330.00
208v three phase 200 amp	\$2,965.00	\$3,710.00	\$4,450.00
208v three phase 400 amp	\$5,240.00	\$6,550.00	\$7,860.00
480v three phase 30 amp	\$990.00	\$1,235.00	\$1,485.00
480v three phase 60 amp	\$1,715.00	\$2,145.00	\$2,570.00
480v three phase 100 amp	\$3,165.00	\$3,960.00	\$4,750.00
480v three phase 200 amp	\$6,290.00	\$7,865.00	\$9,440.00

STANDARD CONNECTIONS (120 VOLT POWER)	DISCOUNT	STANDARD	ON-SITE
<b>500 watt box</b> One 5 amp circuit and one receptacle or plug point	\$125.00	\$155.00	\$190.00
<b>1000 watt box</b> One 10 amp circuit and two receptacles or plug points	\$165.00	\$205.00	\$245.00
<b>2000 watt box</b> One 20 amp circuit and a minimum of three receptacles or plug points	\$205.00	\$255.00	\$310.00
<b>4000 watt box</b> Two 20 amp circuits and a minimum of three receptacles or plug points	\$240.00	\$295.00	\$355.00

ADDITIONAL ELECTRICAL SERVICES & EQUIPMENT	DISCOUNT	STANDARD	ON-SITE
<b>25' round extension cords</b> 25' round, yellow extension cords for use in exhibit booths. Each cord has three, three-prong receptacles on the end.  <i>*Please Note: These extension cords cannot be used to run underneath booth carpeting.</i>	\$36.00	\$45.00	\$55.00
<b>6 Port Power Strip</b>	\$25.00	\$25.00	\$25.00
<b>24 hour power</b> If booth equipment requires electricity 24 hrs a day (for example, a Refrigerator), then the exhibitor should order 24 hr power.  In general, electrical service begins half an hour before the show and ends one hour after the show closes.	<b>Add 50% to Initial Connection Rate</b>		

## OVERHEAD POWER

Overhead power is available upon approval by the MCCA:

- At the Boston Convention & Exhibition Center, overhead 120v electrical is limited due to the ceiling heights. Overhead service is available under the low mechanical roof on the East and West sides of the Halls.
- If an overhead sign, truss, banner or other rigged item requires overhead 120v power, the MCCA can provide this service in any area of the BCEC.
- If an overhead sign, truss, banner or other rigged item requires overhead 208v or 480v power, the MCCA can provide this service in limited areas of the BCEC. Please contact the MCCA Exhibitor Services team for availability.
- Overhead power must accompany a rigging order.

## Installation & Distribution

- MCCA Electricians will provide the initial electrical power source.
- Electrical Service is brought from the nearest column or floor port into the booth. The electrical outlets or boxes are placed in the rear of the booth along the pipe & drape line.
- Electrical boxes are left accessible inside floor ports for island booths with no pipe and drape lines and no columns in their booth space.
- For 208V & 480V connections, we require floor plans so that we may provide the electrical service in a convenient location within the booth.
- Exhibitors are responsible for distributing their own 120V electrical cords and plugging in their booth equipment. Exhibitors may choose to:
  - » Hire labor from the General Service Contractor;
  - » Hire a third-party Installation & Dismantle (I&D) team to perform the distribution work;
  - » Bring their own company electrician to perform distribution and hardwire connections as long as he/she is a full time employee of the exhibiting company.

## Terms & Conditions

- The MCCA is the exclusive provider of electrical service. All electrical equipment shall remain the property of the MCCA and may not be installed or removed by anyone other than MCCA personnel.
- All services listed include labor to install and remove said service. Rates do not include connecting of equipment, tracing of malfunctions, special wiring, or repairs. If an exhibitor requires additional electrical labor outside of the standard service, services will be billed at an hourly rate with a minimum of one hour. Labor rates are based on current wage and benefit rates and are subject to change without notice:
  - » Hourly Rate (All times) \$90.00
- The use of open clip sockets, duplex or triplex attachment plugs, latex or lamp cord is prohibited. All cords must be of the 3 wire grounded type and UL approved. Cords can be no smaller than 12 wire or 12 gauge. Any exposed non-current carrying metal parts of fixed equipment must be grounded.
- Electrical equipment must be properly tagged and wired with complete information as to type of current, voltage, phase, cycle, horsepower, etc.
- The MCCA cannot be responsible for voltage variations of the power company.

## FREQUENTLY ASKED QUESTIONS

### **If the MCCA doesn't run my electrical cords, and I can't do it myself, who should I send my electrical layout plan to?**

If you have booth floor plans that include electrical layouts, you should share that information with your preferred setup personnel. If you are working with a third-party exhibit company, they may run the cords for you. If you need to hire labor to run cords for you, the show's General Service Contractor can help you. Typically, the General Service Contractor will include an Electrical Cord Labor Form in the Exhibitor Kit. The MCCA is happy to keep any floor plans on file for reference. In fact, we recommend that you forward your electrical layouts to Exhibitor Services for all 208V and 480V connections so that we may place the initial drop in the most convenient location possible.

**How do I know if I need a 208V or 480V connection?**

Most exhibitors do not require special connections like a 208V or 480V connection. Many times, these types of electrical services are required for heavy equipment and/or specialized machinery. Kindly consult with the equipment manufacturer, name plate rating or installation technician for specific details. Exhibitors who bring their own distribution panels may need one of these special connections.

**How do I know how much power I need to order?**

When determining how much power to order for a booth, it is helpful to know how much total power is required for the equipment in your booth space. Below, we have outlined some standard electrical requirements (requirements may vary).

- Standard Laptop . . . . . 250-550 watts
- Lead Retrieval . . . . . 300-500 watts
- Standard Plasma TV . . . . . 300-400 watts

Items like laptops, standard booth lights, and televisions may be grouped together on one circuit provided they do not exceed the overall limit of the circuit or the surge protection device. There is some equipment that requires its own circuit to run properly. For example, a microwave or refrigerator requires its own dedicated circuit, so a laptop and refrigerator should not use the same power source.

**I am an International Exhibitor and my equipment requires a converter to step down from 220V to 208V. Can I rent a converter from the MCCA?**

The MCCA does not rent or supply power conversion equipment. Exhibitors are required to bring their own to the show.

**I can't find 208V or 480V overhead service listed on your online ordering site. How can I order this service?**

208V & 480V overhead services are limited in our convention centers. All requests for such connections must be approved by an MCCA electrician; please contact MCCA Exhibitor Services for more information.

# Telephone Services

The MCCA offers a variety of telephone services through our experienced in-house telephone technicians.

STANDARD TELEPHONE SERVICES	DISCOUNT	STANDARD	ON-SITE
<b>Single-Line Service (Analog)</b> Service includes one phone number and a complimentary simple handset. Line usage included.	\$295.00	\$365.00	\$440.00
<b>Multi-Line Service (Digital)</b> Service includes one phone number with multiple line appearances and rental of one digital display phone. Equipment must be returned at the close of the show. Line usage included.	\$425.00	\$530.00	\$635.00
<b>Speaker Phone Service (Analog)</b> Service includes one phone number and rental of one speaker phone. Equipment must be returned at the close of the show. Line usage included.	\$325.00	\$410.00	\$490.00
<b>Polycom Speaker Phone Service (Analog)</b> Service includes one phone number and rental of one polycom speaker phone. Equipment must be returned at the close of the show. Line usage included.	\$380.00	\$475.00	\$570.00

ADDITIONAL TELEPHONE SERVICES AND EQUIPMENT	DISCOUNT	STANDARD	ON-SITE
<b>Call Waiting (per phone line)</b> Allows user to know when another call is coming in.	\$50.00	\$65.00	\$80.00
<b>Voicemail (per phone line)</b> Allows user to setup a custom greeting and receive messages from incoming callers.	\$50.00	\$65.00	\$80.00
<b>ISDN/BRI Service</b> ISDN lines support video and CODEC applications. ISDN lines can be arranged by contacting your Event Services Manager two weeks prior to show. Exhibitors can select one of two long distance carriers: AT&T or Verizon. Line usage will be billed per the selected carrier's rate after the close of the show.	\$305.00	\$385.00	\$460.00
<b>Polycom Videoconference Rental w/ISDN</b> This service is used to connect from the MCCA's facility to an external/remote site with like ISDN video conferencing capabilities. This service includes three 128k ISDN lines. Line usage will be billed per the selected carrier's rate after the close of the show.	\$2,040.00	\$2,550.00	\$3,060.00
<b>Polycom Videoconference Rental w/IP Connect Service</b> This service is used to connect from the MCCA's facility to an external/remote site with like IP video conferencing capabilities. Service includes IP connectivity for video conferencing. The distant video equipment must be IP compatible.	\$1,120.00	\$1,630.00	\$1,955.00

## INSTALLATION & CONNECTIONS

- Telephone Service is brought from the nearest column or floor port into the booth.
- MCCA phone technicians typically provide a line that is long enough to run anywhere in your booth. Exhibitors may have their preferred setup personnel run their phone cord(s) under the carpet to desired locations, or they may hire the General Service Contractor to do so.
- All telephone equipment can be picked up at the MCCA Exhibitor Services Desk.

### Terms & Conditions

- The MCCA is the exclusive provider of all telephone services. All telephone equipment shall remain the property of the MCCA and may not be installed or removed by anyone other than MCCA personnel.
- All MCCA telephone equipment (except simple analog handset) must be returned to the Exhibitor Service Desk at the close of the show. Failure to return MCCA phones will result in a replacement fee.
- All services listed include labor to install and remove said service. Rates do not include connecting of equipment, tracing of malfunctions, special wiring, or repairs. If an exhibitor requires additional telephone labor outside of the standard service, services will be billed at an hourly rate with a minimum of one hour. Labor rates are based on current wage and benefit rates and are subject to change without notice:
  - » Hourly Rate (All times) \$90.00

## FREQUENTLY ASKED QUESTIONS

### How do I know if I need a single-line or a multi-line service?

Single-line phones are just like most household phones. They can be used for fax lines, credit card machines, standard telephones, and even to dial-up internet service (although we do not recommend this method of internet connectivity). A Multi-Line Service (Digital) includes one phone number with multiple line appearances and rental of one digital display phone.

### I have a wired credit card machine. Do I need to program anything specific for the machine to work on your single-line service?

Yes. Please preprogram your machine to dial “9” before your credit card company’s number.

### How do I receive my phone number, dialing instructions, and phone/fax equipment?

Please visit the MCCA Exhibitor Services desk onsite to pick up your equipment. At this time you will receive assigned phone numbers and dialing instructions. This information can also be provided ahead of time if requested through Exhibitor Services.

### How can I place international calls on my phone line?

If you wish to place international calls on your phone line, please contact Exhibitor Services prior to move-in to submit this request. Otherwise, all phones will be limited to local and US numbers.

# Internet & Technical Services

*The MCCA offers a variety of Internet and Technical services through our experienced in-house team of technicians.*

## Wired Internet Connections

Exhibitors who order wired internet drops are provided with one internet connection and assistance, as needed, from our internal IT Support Services staff. All MCCA Internet services include one initial line regardless of how many IPs are ordered with the service. To have more than one computer connected at one time, exhibitors may bring their own switch or hub device and cables, or they may purchase a switch from the MCCA. Exhibitors are asked to read through the following service descriptions closely to ensure that the purchased service level is sufficient to meet their bandwidth requirements during the entirety of the show. Below are basic guidelines for ordering wired Internet services.

All services are delivered DHCP. Public IP addresses are available upon request with all of our managed services listed below. Public IP addresses are not available with our Basic Service Package. Managed Services requesting public IP addresses require manual configuration to each machine.

Custom orders for bandwidth above listed service levels below can be ordered on a case-by-case basis through the MCCA's Exhibitor Services Department at **617-954-2230** or [exhibitorservices@signatureboston.com](mailto:exhibitorservices@signatureboston.com).

<b>MANAGED SERVICES</b> Manually configured services require entry of IP addresses into the device before the device may access the internet.	<b>DISCOUNT</b>	<b>STANDARD</b>	<b>ON-SITE</b>
<b>Basic Service Package</b> The Basic Service Package includes a private VLAN and subnet. This level is sufficient if the main use is for a basic internet connection, such as for e-mail or internet browsing. The Basic Service package may not be fast enough for streaming video or multi-purpose use. Public IP addresses are not available with this service.	\$955.00	\$1,020.00	\$1,225.00
<b>1.54 Mbps Managed Service</b> The 1.54 Mbps Managed Service Package includes a private VLAN and subnet. This level is sufficient if the main use is for a basic internet connection, such as e-mail, internet browsing, or standard definition video streaming. It may not be fast enough for multi-purpose use. Public IP addresses available upon request.	\$1,935.00	\$2,295.00	\$2,755.00
<b>3 Mbps Managed Service</b> The 3 Mbps has more bandwidth than the 1.54 Mbps service and includes a private VLAN and subnet. Public IP addresses are available upon request. This level is sufficient for basic e-mail and web browsing, standard definition video streaming, or can accommodate multiple Internet connections.	\$4,710.00	\$5,405.00	\$6,485.00
<b>6 Mbps Managed Service</b> The 6 Mbps has more bandwidth than the 3 Mbps service and includes a private VLAN and subnet. Public IP addresses are available upon request. This level is sufficient for 4 standard definition video streams, or a single HD video stream, or can accommodate multiple Internet connections.	\$7,965.00	\$9,180.00	\$11,015.00
<b>10 Mbps Managed Service</b> The 10 Mbps service includes a private VLAN and subnet. Public IP addresses are available upon request. This level is sufficient for 6 standard definition video streams, a single HD video stream, or can accommodate multiple Internet connections.	\$10,660.00	\$12,240.00	\$14,690.00

<b>15 Mbps Managed Service</b> The 15 Mbps service includes a private VLAN and subnet. Public IP addresses are available upon request. This level is sufficient for 2 HD video streams, or a single 4K stream, or can accommodate multiple Internet connections.	\$15,710.00	\$18,055.00	\$21,665.00
<b>20 Mbps Managed Service</b> The 20 Mbps service includes a private VLAN and subnet. Public IP addresses are available upon request. This level is sufficient for 3 HD video streams, or a single 4K stream, or can accommodate multiple Internet connections.	\$20,870.00	\$24,000.00	\$28,800.00
<b>25 Mbps Managed Service</b> The 25 Mbps service includes a private VLAN and subnet. Public IP addresses are available upon request. This level is sufficient for 4 HD video streams, or a single 4K stream, or can accommodate multiple Internet connections.	\$25,920.00	\$29,835.00	\$35,800.00
<b>30 Mbps Managed Service</b> The 30 Mbps service includes a private VLAN and subnet. Public IP addresses are available upon request. This level is sufficient for 5 HD video streams, or up to two 4K video streams, or can accommodate multiple Internet connections.	\$30,855.00	\$35,495.00	\$42,595.00
<b>35 Mbps Managed Service</b> The 35 Mbps service includes a private VLAN and subnet. Public IP addresses are available upon request. This level is sufficient for 5 HD video streams, or up to two 4K video streams, or can accommodate multiple Internet connections.	\$35,905.00	\$41,310.00	\$49,570.00
<b>40 Mbps Managed Service</b> The 40 Mbps service includes a private VLAN and subnet. Public IP addresses are available upon request. This level is sufficient for 6 HD video streams, or up to two 4K video streams, or can accommodate multiple Internet connections.	\$40,615.00	\$46,715.00	\$56,060.00

ADDITIONAL INTERNET SERVICES & EQUIPMENT	DISCOUNT	STANDARD	ON-SITE
<b>Copper Patch/ Booth to Booth Connection</b> Copper Patch is a method of connecting computers or network equipment that may be in different locations in the facility. Copper patches can transmit data, audio, and video. This is not available with the shared service.	\$345.00	\$430.00	\$515.00
<b>Fiber Patch/ Booth to Booth Connection</b> Fiber Patch is a method of connecting computers or network equipment that may be in different locations in the facility. Fiber patches can transmit data, audio, and video.	\$480.00	\$600.00	\$720.00
<b>Switch-8 Port</b> This switch can connect up to 7 computers or devices together, giving all access to the internet service ordered.	\$105.00	\$135.00	\$160.00
<b>Switch-24 Port</b> This switch can connect up to 23 computers or devices together, giving all access to the internet service ordered.	\$360.00	\$455.00	\$545.00
25' CAT 5e Cable	\$46.00	\$57.00	\$70.00
50' CAT 5e Cable	\$62.00	\$80.00	\$95.00
100' CAT 5e Cable	\$100.00	\$120.00	\$145.00
Coupler	\$15.00	\$20.00	\$25.00

TECHNICAL SERVICES	DISCOUNT	STANDARD	ON-SITE
<b>Cable TV Service</b> Cable TV service is basic business cable service provided by Comcast Cable. Service is provided to booths from floor boxes or columns.	\$250.00	\$315.00	\$375.00
<b>CATV Tuner (Only available at the BCEC)</b> For TVs that are not cable-ready (including some plasmas), the CATV tuner interprets the signal and allows you to tune the signal. It functions similar to your cable box at home.	\$57.00	\$72.00	\$85.00
<b>CATV Tap Box</b> A distribution box which allows up to 16 CATV feeds from a single cable tap.	\$205.00	\$255.00	\$305.00

\* For advanced Technical Service offerings, consult the online ordering site or contact MCCA Exhibitor Services.

## INSTALLATION & CONNECTIONS

- MCCA technicians will provide one initial network cable.
- Internet Service is brought from the nearest column or floor port into the booth.
- All MCCA internet services come with one initial line regardless of how many IPs are ordered with the service. To have more than one computer connected at one time, exhibitors may bring their own routing device and cables or may purchase a switch and purchase cables from the MCCA.
- Exhibitors are required to distribute their own internet cables.
- Exhibitors may choose to:
  - » Hire labor from the General Service Contractor or;
  - » Hire a third-party Installation & Dismantle (I&D) team to perform the distribution work.

## Terms & Conditions

- The MCCA is the exclusive provider of internet services.
- All services listed include labor to install and remove said service. Services do not include connecting of equipment, tracing of malfunctions, special wiring, or repairs. If an exhibitor requires additional internet labor outside of the standard service, services will be billed at an hourly rate with a minimum of one hour. Labor rates are based on current wage and benefit rates and are subject to change without notice:
  - » Tech Rep (All times) \$120.00
  - » Network Engineer (All times) \$150.00
- The MCCA will provide an Ethernet connection to a shared data network attachment for the use of Exhibitor's directors, officers, employees and guests during the official dates of specified show.
- Exhibitor will be responsible for providing all hardware, software and other equipment and facilities needed to connect to the Ethernet and to use network attachment.
- The network attachment provided by the MCCA may be used only by the Exhibitor's directors, officers, employees and guest, agents, or consultants. The MCCA network

will facilitate communications between the company's authorized users and entities reachable through the national internet.

- The Exhibitor will promote efficient use of provided networks to minimize and avoid unnecessary network traffic and interference with the work of other users on interconnected networks.
- Users of MCCA networks shall not disrupt any of the MCCA networks or any other MCCA associated networks.
- MCCA networks shall not be used to transmit any communication where the meaning of the message, or its transmission or distribution, would violate any applicable law or regulation or would be highly offensive to the recipient or recipients thereof. Mass distribution of any message, including advertising, may not be broadcast or otherwise sent on an intrusive basis to any user of the MCCA network or any directly or indirectly attached network. When requested by a user of the networks, product information and other commercial messages are permitted to be transmitted. Discussion of a product's relative advantages and disadvantages by users of the product and vendors' response to those who pose questions about their products may be made available over the MCCA networks. Interpretation application and possible modification shall be within the sole discretion of MCCA.
- MCCA does not make any express or implied warranty of any kind specifically. There is no express or implied warranty of merchantability or fitness for a particular purpose for the services to be provided. The protocol used on the MCCA network call for end to end verification of the accuracy of any message and such verification is the sole responsibility of the purchasing company. Similarly, these protocols provide for end to end verification of the receipt of all the data that is transmitted. MCCA will not be responsible for any loss of data from delays, non-deliveries, incorrect deliveries, service interruptions, including those caused by the negligence, errors or omissions of the MCCA, or other losses or damages. Use of information obtained via the services provided hereunder is at purchasing company's own risk. Exhibitor is responsible for (a) the accuracy and/or quality of the information obtained or data transmitted through the MCCA network and (b) assuring that each message purchasing company sends or receives has been received.

- MCCA shall not be liable to Exhibitor for any damage arising from any event that is out of the control of the MCCA. Neither shall the MCCA be liable to Exhibitor for indirect, special, incidental, exemplary, consequential or any other form of money damage, including, but not limited to, lost profits, or of the loss of data or information of any kind, however caused, and arising out of or in connection with the performance of MCCA, or the provision of services or performance hereunder, whether based in contract, tort, or any other legal theory, and whether or not MCCA has been made aware of the possibility of such damages.
- In no event shall liability exceed a refund of amounts actually paid to MCCA by Exhibitor for this network attachment.
- The network attachment shall be made available to Exhibitor by MCCA before the beginning through the end of the specified conference.
- The MCCA will provide a network attachment via an Ethernet connection at the Exhibitor's booth. At its own expense, the Exhibitor is responsible for providing the computer, attachment to Ethernet, electric power and all other hardware and software required to use the network attachment.

## FREQUENTLY ASKED QUESTIONS

### **I ordered a Managed Service that required IP Addresses.**

#### **How and when do I receive this information?**

When you are onsite and ready to configure your computers, please visit the Exhibitor Services desk to retrieve your IP Information.

### **Do you have wireless internet?**

The MCCA offers free wireless internet service throughout meeting rooms, lobbies, and expo halls; just open your internet browser and look for the BCEC Wireless Network. This service is designed for casual users and not guaranteed. If you are relying on the internet to showcase your product or services we strongly recommend a wired internet connection for guaranteed service.

### **I see that you don't offer hubs for sale. What is the difference between a hub and a switch? Can I bring my own hub or switch?**

The MCCA offers switch devices for sale instead of hubs because switches are known to provide better performance with a lower failure rate. Exhibitors are welcome to provide their own hub or switch for all internet services.

### **What is bandwidth and how do I know how much I need?**

Bandwidth is the "size of the pipe" that data can traverse. The bigger the bandwidth, the faster data can be transferred. To find out how much bandwidth you require, please consult with a technical representative in your company or look for program specifications listed with any demonstrations or downloads you plan to run.

### **I need to access my company's network while I'm exhibiting at your facility. Which service will allow me to do this?**

Exhibitors who need to connect remotely to their company's network using a VPN (Virtual Private Network) with authentication information like passwords, certificates, or "tokens" can do so with any of our services, however they should confirm with their IT department for the use of DHCP or public IP address requirements.

### **What is a VLAN?**

A VLAN (Virtual Local Area Network) allows a network of computers to behave as if they are connected to the same service even though they may actually be physically located in different areas around the facility. One of the biggest advantages of a VLAN is that when a computer is physically moved to a different location, it can stay on the same VLAN without any hardware reconfiguration.

### **I ordered a switch and cables, how and when do I get them?**

When you are ready for your switch and internet cables, please visit the Exhibitor Services Desk.

# Rigging Services

The MCCA provides rigging and overhead lighting services through our service contractor, JCALPRO.

## Planning Ahead for Rigging & Lighting Services

Diagrams and booth layouts are essential for planning rigging and lighting services. In order to ensure efficient delivery of required services, Exhibitors must submit rigging plots, drawing, blueprints, or engineers' certification with their orders. Diagrams must include the location, dimensions and weight, and the height from the floor to the top of the suspended item. Diagrams must also show booth outline with aisles or neighboring booths marked for reference and orientation.

<b>PACKAGE RIGGING SOLUTIONS</b> The MCCA offers package rigging solutions for exhibitors with basic and straight forward sign hanging needs. To qualify for the packages, exhibitors must be flexible with regards to days and times of load-in and take-down.	DISCOUNT	STANDARD	ON-SITE
<b>Basic Rigging Package</b> This package includes all lifts, labor, and rigging equipment (cables, pipes, and hardware) necessary to install and take down one sign/banner weighing less than 150lbs, measuring less than 20' in length, and less than 175 square feet. The package service is provided during standard service hours, Monday-Saturday 7am – 12am, except holidays. If service is required outside these times, then a Team Labor Hour must be ordered in addition to the package.	\$1,736.00	\$2,083.00	\$2,500.00
<b>Electrical Rigging Package</b> This package includes the Basic Rigging Package plus labor to connect electrical service to an Exhibitor sign/banner. Overhead electrical service for rotator, motor or lighted sign must be ordered separately. Please see Electrical services section for details.	\$2,009.00	\$2,411.00	\$2,893.00
<b>Team Labor Hour</b> Exhibitors may request rigging service on Sundays, holidays or outside the package service hours (Monday-Saturday 7am – 12am). In this case, a Team Labor Hour must be ordered for each rigging package ordered. In addition, when receiving a custom quote for rigging and lighting, team labor hours will be quoted for all labor hours required that are not covered by the Rigging Packages such as building of truss, focusing and attachment of lights, and lighting maintenance.	\$273.00	\$328.00	\$394.00

## Custom Rigging & Lighting Solutions

The MCCA/JCALPRO also offers customized rigging and lighting solutions for Exhibitors with more complex or unique requirements. This option is best suited for Exhibitors with larger signs, multiple signs, and/or overhead lighting needs.

Custom Rigging and Lighting Solutions still require flexibility in load in and load out time. If you require a specific load in or load out day and/or time, hourly rates may apply (see Terms and Conditions – Page 17).

Custom Rigging & Lighting solutions may only be ordered with a pre-arranged quote.

Please contact JCALPRO at 1.617.954.2345 to initiate this process. Quotes will be issued in an easy-to-order format, and will typically include a base Rigging Package for labor charges and some combination of the following items as necessary.

\* For Custom Rigging please contact JCALPRO at 617.954.2345, as these services are not available for online ordering.

CUSTOM RIGGING SOLUTIONS	DISCOUNT	STANDARD	ON-SITE
<b>Truss</b> A truss is an aluminum structure used to create a lower “ceiling” to hang lighting or other suspended items. It is available in 5’, 8’, or 10’ sections which can be attached to create desired lengths or height.			
Truss 5’ Section – Silver 12”x12” Box	\$28.00	\$34.00	\$40.00
Truss 8’ Section – Silver 12”x12” Box	\$45.00	\$54.00	\$65.00
Truss 10’ Section – Silver 12”x12” Box	\$56.00	\$67.00	\$81.00
Truss 5’ Section – Black 12”x12” Box	\$39.00	\$47.00	\$56.00
Truss 8’ Section – Black 12”x12” Box	\$63.00	\$75.00	\$90.00
Truss 10’ Section – Black 12”x12” Box	\$78.00	\$94.00	\$113.00
Truss 5’ Section – Silver 20.5”x20.5” Box	\$50.00	\$60.00	\$73.00
Truss 8’ Section – Silver 20.5”x20.5” Box	\$81.00	\$97.00	\$116.00
Truss 10’ Section – Silver 20.5”x20.5” Box	\$101.00	\$121.00	\$145.00
<b>Corner Block</b> A corner block is an aluminum piece that attaches to truss to create a right angle.			
Corner Block – Silver 12”x12” Box	\$56.00	\$67.00	\$81.00
Corner Block – Black 12”x12” Box	\$73.00	\$87.00	\$105.00
Corner Block – Silver 20.5”x20.5” Box	\$78.00	\$94.00	\$113.00
<b>Base Plate</b> A base plate is used as a stand for ground supported truss or poles.	\$39.00	\$47.00	\$56.00
<b>Rotator</b> A rotator is a motor used to rotate a hanging sign.	\$168.00	\$202.00	\$242.00
<b>Motor</b> A motor is a motorized pulley that is rigged to the ceiling and attached to truss to achieve a desired height. Motors are also used to safely suspend heavier items that cannot be supported by cables alone. Motors are available in ¼ ton, ½ ton, and 1 ton capacities.	\$168.00	\$202.00	\$242.00

<b>Cheeseboro</b> A cheeseboro is a clamp used to attach two pieces of truss or pipe together.	\$7.00	\$8.00	\$10.00
<b>Grapple</b> A grapple is a connector that allows you to make a 90 degree connection between trusses.	\$13.00	\$16.00	\$19.00

<b>LIGHTING FIXTURES</b> A variety of lighting options are available to brighten exhibit space. While lights cannot be attached directly to our ceiling, lighting can be suspended above exhibit space by utilizing truss and motors.	DISCOUNT	STANDARD	ON-SITE
<b>Source 4 Par (575 watt, 750 watt)</b> This fixture is best used to create a wash effect or cover a larger area with light. It is available in 575 watt or 750 watt. Lenses are available in Very Narrow (VNSP), Narrow (NSP), Medium (MFL), Wide (WFL).	\$39.00	\$47.00	\$56.00
<b>Source 4 Leko (575, 750 watt)</b> This fixture is best used to create a spot light or to highlight specific spaces or objects. It is available in 575 watt or 750 watt. Lenses come in 19, 26, 36, 50 degrees to achieve the desired illumination from the light.	\$50.00	\$60.00	\$73.00
<b>Par 64 (1000 watt)</b> The Par 64 will deliver similar results as the S4Par, but there are no options for additional lenses. They are available in 1000 watts.	\$34.00	\$40.00	\$48.00

<b>CUSTOM LIGHTING SOLUTIONS</b> Lighting kits include a combination of Lekos, Source 4 Pars and Par 64s based on layout and design requirements. Price includes fixtures, fixture accessories and all necessary cables. Dimmer/control and labor are not included and must be ordered separately. Special Orders for larger kits are available upon request.	DISCOUNT	STANDARD	ON-SITE
<b>Small Lighting Kit (4-6 lights)</b>	\$207.00	\$249.00	\$298.00
<b>Medium Lighting Kit (7-11 lights)</b>	\$364.00	\$437.00	\$524.00
<b>Large Lighting Kit (12-15 lights)</b>	\$504.00	\$605.00	\$726.00
<b>X-Large Lighting Kit (16-20 lights)</b>	\$616.00	\$739.00	\$887.00

DIMMER RACKS & LIGHTING CONTROLS			
These items are optional with individual fixtures or small lighting kits, but mandatory with larger lighting kits. The dimmer rack is a large “outlet” that all lights plug into to create a central control location. A dimmer rack, depending upon size, can be placed in a booth or attached to the truss and kept in the air. The lighting console/control plugs into the dimmer rack to dim or control individual lights, groups of lights, or all lights at once.  Electrical service is not included and must be ordered separately.	DISCOUNT	STANDARD	ON-SITE
Dimmer Control 1.2 x 4	\$90.00	\$108.00	\$129.00
Dimmer Control 2.4 x 12	\$168.00	\$202.00	\$242.00
Dimmer Control 2.4 x 24	\$358.00	\$430.00	\$516.00

### Terms & Conditions

- JCALPRO is the exclusive rigging vendor at the Boston Convention & Exhibition Center (BCEC). If an exhibitor is exhibiting at the BCEC and requires rigging services for the booth, JCALPRO is the only vendor authorized to hang signs, banners, or lighting in the booth space.
- If an Exhibitor requires specific load-in/load-out dates and/or times, then a base rigging package may not be applicable. In this case, a special quote for required crew and lift equipment will be prepared using the following hourly labor and weekly lift rental rates:

HOURLY LABOR ITEMS	MON-SAT 7AM-12AM (EXCEPT HOLIDAYS)	SUNDAYS 7AM-5PM AND HOLIDAYS	SUNDAYS AFTER 5PM ALL DAYS 12AM-7AM
Crew Chief	\$100.00	\$150.00	\$200.00
Head Rigger	\$100.00	\$150.00	\$200.00
Rigger	\$89.00	\$134.00	\$178.00
Dept Head	\$76.00	\$114.00	\$152.00
Stagehand	\$71.00	\$107.00	\$142.00

WEEKLY LIFT RENTAL ITEMS	RATE
24'- 32' Scissor Lift	\$750.00
40'- 45' Boom Lift	\$950.00
60' Boom Lift	\$1,600.00

- All rigging must conform to the rules, regulations, and facility limitations of the MCCA and any show management regulations.
- All equipment, signs, products, etc. must be designed to suspend safely. Care must be taken to use only rated rigging hardware when designing, constructing or purchasing such items. Any equipment, signs, products etc. deemed to be unsafe for overhead suspension by MCCA/JCALPRO will be substituted or denied.
- The use of any type of tape/adhesive for attaching signs, banners, or decorations to the building walls or decorative surfaces is not permitted.
- All assembly of equipment, signs, products necessary prior to hanging, etc., will be the responsibility of the Exhibitor.
- Failure by Exhibitor to submit accurate diagrams prior to load-in will delay set-up and could incur additional cost.

## FREQUENTLY ASKED QUESTIONS

### How do I know if I qualify for the Basic Rigging Package Rate?

Find out the dimensions and weight of your sign. If your sign weighs less than 150 pounds and is less than 20' in length and less than 175 square feet and does not require electrical rigging, truss, or motors, you will qualify for the Basic Rigging Package. If your sign is motorized or needs electrical rigging (for example a rotating sign or a sign with lights), you qualify for the Electrical Rigging Package.

### Can I order lighting to be suspended from the ceiling?

If you would like to order lights to brighten up your booth or illuminate specific objects, you will need to get a **quote** from JCALPRO. In most cases, lights cannot be attached to our ceilings. Instead we can provide you with truss, using motors, to create a lower "ceiling" and then hang lights from that truss. We will require a diagram showing your booth layout and exactly what you want illuminated in order to put together a quote.

### Do I ship my sign to you to put it together?

No. Although JCALPRO provides labor to hang the sign, the General Service Contractor (GSC) handles all shipments. You may build your sign or hire the GSC to put it together for you. When the sign has arrived at the building and has been assembled, we will hang it for you. Be sure to keep this in mind when making your time and day requests for sign hanging.

### Can I request load in and load out times?

Yes, the Rigging Order Form has a space for you to indicate your preferred up and down times. Please note that your preferred timing is not guaranteed; however, we do try our best to cater to your requests. If you absolutely need a specific install or take down time, additional charges will apply. If you do not provide a diagram or layout prior to load-in, then you may experience set-up delays and additional cost.

### What type of diagrams should I send?

The most useful diagrams are on a proportioned grid to show the dimensions of the booth, the exact desired placement of hanging items, and orientation of the booths around yours. As a general rule, pictures from previous shows and pictures of the sign only are not as helpful as current diagrams of the entire booth space with the placement, height, and weight of the sign(s) or hanging item(s).

# Plumbing Services

The MCCA offers a variety of plumbing services through our experienced in-house team of plumbers.

WATER AND DRAIN SERVICES	DISCOUNT	STANDARD	ON-SITE
<b>Water – Individual Connection</b> Water service is available at approximately 75 PSI with up to ¾” supply line. Water flows at five gallons per minute. Please note that this is cold water.	\$335.00	\$420.00	\$505.00
<b>Additional Water Connections</b> Clients requiring more than an individual water connection should order each additional connection as needed.	\$195.00	\$245.00	\$295.00
<b>Drain – Individual Connection</b> The MCCA can provide waste drain connections up to ¾” line size.	\$335.00	\$420.00	\$505.00
<b>Additional Drain Connections</b> Clients requiring more than an individual drain connection should order each additional connection as needed.	\$180.00	\$225.00	\$270.00
<b>Fill and Drain 0-100 Gallons</b> Clients that need equipment to be filled with water at the beginning of a show and emptied at the end of a show should order a Fill and Drain service. Please contact your MCCA Event Services Manager when equipment is ready to be filled.	\$170.00	\$210.00	\$250.00
<b>Each Additional 500 Gallons</b>	\$115.00	\$145.00	\$175.00

SINK RENTALS	DISCOUNT	STANDARD	ON-SITE
<b>Cold Water Sink Rental</b> Cold water sink rental includes a single-tub basin (20”L x 24”W x 34”H), one water connection, and one drain connection. Legs allow the units to sit 34” above the floor.	\$675.00	\$840.00	\$1,010.00
<b>Small Hot &amp; Cold Water Sink Rental</b> Small Hot & Cold water sink rental includes a single-tub basin (20”L x 24”W x 34”H), a hot water heater (6 gallon capacity), dedicated power, two water connections, and one drain connection.	\$900.00	\$1,120.00	\$1,345.00
<b>Large Hot &amp; Cold Water Sink Rental</b> Large Hot & Cold water sink rental includes a 3-tub basin (57”L x 24.5”W x 43”H), a hot water heater (6 gallon capacity), dedicated power, two water connections, and one drain connection. This service is available in specific areas of the exhibition hall. Please contact your MCCA Event Services Manager for more information.	\$1,120.00	\$1,405.00	\$1,685.00

COMPRESSED AIR AND GASSES	DISCOUNT	STANDARD	ON-SITE
<b>Compressed Air – Individual Connection</b> Compressed Air is delivered at approximately 110 psi and a dew point of 35 degrees F (medical instrument quality).	\$410.00	\$510.00	\$610.00
<b>Additional Connection</b> Clients who require more than an individual connection should order additional connections as needed.	\$210.00	\$265.00	\$320.00
<b>OTHER COMPRESSED GASES</b> The MCCA provides a variety of bottled gases. The most commonly ordered gases are listed below. If other gases not listed are required, the exhibitor should contact MCCA Exhibitor Services. Flammable gases are not permitted in MCCA facilities. Please note that in order to ensure delivery of service, orders need to be received one week prior to move-in.			
20 Lbs Dry or Liquid CO <sub>2</sub>	\$170.00	\$205.00	\$245.00
50 Lbs Dry or Liquid CO <sub>2</sub>	\$190.00	\$225.00	\$270.00
Dry Nitrogen 300 ft <sup>3</sup>	\$230.00	\$280.00	\$335.00

## INSTALLATION & CONNECTIONS

- Plumbing Service is brought from the nearest column or floor port into the booth.
- Air and Water connections are available in limited locations on the exhibit floor. Connection sizes and booth locations all factor into planning to supply air and water to exhibitors. Please provide a floor plan of the exhibit space indicating locations that require air or water service as well as connection requirements well in advance of exhibitor move-in.

### Terms & Conditions

- The MCCA is the exclusive provider of all plumbing services. All plumbing equipment shall remain the property of the MCCA and may not be installed or removed by anyone other than MCCA Personnel.
- Exhibitors are not permitted to fill or drain their own equipment, use individual air compressors, or bring their own compressed gases from an outside vendor.
- All services listed include labor to install and remove said service. Rates do not include connecting of equipment, tracing of malfunctions, special wiring, or repairs. If an

exhibitor requires additional plumbing labor outside of the standard service, services will be billed at an hourly rate with a minimum of one hour. Labor rates are based on current wage and benefit rates and are subject to change without notice:

» Hourly Rate (All times) \$90.00

## FREQUENTLY ASKED QUESTIONS

### Do all water connections need a drain?

While most water connections do require a drain service, there are some cases where the drain is unnecessary. When the water provided is being consumed or evaporated, a drain is not needed. For example, exhibitors using water service for a coffee machine do not need to order a drain because the water is being consumed.

### Will you provide the fittings and hoses for my water and drain connections?

To ensure that your booth's equipment runs properly we ask that you supply your own regulators, filters, and hoses.

**When would I need to order a Fill and Drain Service?**

Some of the most common reasons exhibitors order fill and drain are for items like fish tanks, pools, tubs for display, or running water displays. We use large hoses to fill vessels requiring water and then use existing drains in the floor to remove the water at the end of the show. Exhibitors are not permitted to bring their own water or use MCCA sinks to fill their own equipment.

**My booth requires a sprinkler system. What plumbing service should I order?**

If your booth requires a sprinkler system, you will need to order an individual water connection specifically for this purpose.

**My exhibitor kit says I need to order a hand washing unit because I am planning to prepare food in my booth. Do you provide these units?**

Levy Restaurants, our exclusive in-house catering company, can provide a hand washing unit that includes a small hand washing sink, paper towels, soap, and a discard bucket. Please consult your exhibitor kit for Levy Restaurants information or contact them directly at the BCEC (617.954.2382).

**Do you allow Exhibitors to bring Helium balloons into your buildings?**

No, unfortunately we do not allow exhibitors to bring helium balloons into the buildings.

# Security Services

*The MCCA is the “preferred” provider of security booth coverage for exhibitors. If your event designates another security vendor for booth coverage, you may choose to order through the event’s preferred provider as detailed in your exhibitor kit.*

SECURITY GUARD (BOOTH)	DISCOUNT	STANDARD	ON-SITE
<b>Per Hour Per Officer</b> The MCCA offers uniformed public safety officers to cover shows and events. Officers are scheduled at a 4-hour minimum and are available from move-in to move-out, around the clock. Orders need to be placed 21 days in advance of the show/event opening in order to guarantee your requested coverage. Any orders received after the 21 day cut-off are subject to approval and are not guaranteed.	\$28.00	\$33.50	\$40.00
<b>Per Hour Per Supervisor</b>	\$38.00	\$45.50	\$54.50

## FREQUENTLY ASKED QUESTIONS

### When do you recommend ordering security for an exhibitor booth?

Our public safety department strongly suggests ordering security for booths planning to have VIP celebrity appearances, book signings etc., to monitor crowd control and escort as needed. Also, exhibitors with expensive or rare equipment in their booths may consider security for the overnight hours between show end and the next day’s show start.

### Is there general overnight security in the exhibit hall?

The MCCA provides 24 hour security coverage for the facility; however, security coverage for the exhibit hall is determined by the show organizer and may vary from event to event.

## **APPENDIX – SERVICE ORDER FORMS**

Request for Exhibitor Electrical Services	22
Request for Exhibitor Telephone Services	23
Request for Internet & Technical Services	24
Request for Rigging & Lighting Services	26
Request for Exhibitor Plumbing Services	28
Request for Exhibitor Security Services	29

## **APPENDIX –**

Exhibitor Guidelines, Information and Regulations	30
Levy Restaurants Sample Food and/or Beverage Distribution Request	41

**Exhibitor Order Form  
Electrical Services**

Effective January 1, 2019

By submitting this order form, Exhibitor acknowledges and accepts all Policies, Terms & Conditions for service as set forth in the MCCA Exhibitor Ordering Guide available at <http://www.signatureboston.com/bcec/bcec-ordering-guide.aspx>.  
**To qualify for discount rate, request and payment must be received 21 days prior to show/event opening.**

**\*Overhead electrical services must accompany a rigging order.**

*Incomplete information will delay processing.*

Event or Show:		Booth no. (s)			
Event or show date(s):		Exhibiting firm:			
Billing address:	City:	State:	Zip:	Country:	
Phone:		Email:			
Ordered by/title:		Show site contact:			
Date:		Contact phone:			

**STANDARD ELECTRICAL CONNECTIONS: 120 VOLT**

Description	Regular Service			Additional Services Available as Add-Ons					Total Due: \$	
	QTY	Discount Rate	Standard Rate	QTY	24-Hour Service	QTY	Overhead Service*	QTY		Combined 24-hour & Overhead*
500 Watt Box (5 amps)		\$125.00	\$155.00		+50% rate		\$155.00		\$232.50	
1000 Watt Box (10 amps)		\$165.00	\$205.00		+50% rate		\$205.00		\$307.50	
2000 Watt Box (20 amps)		\$205.00	\$255.00		+50% rate		\$255.00		\$382.50	
4000 Watt Box (20 amps x 2)		\$240.00	\$295.00		+50% rate		\$295.00		\$442.50	

**STANDARD ELECTRICAL CONNECTIONS: 208 VOLT & 480 VOLT**

Description	Regular Service			Additional Services Available as Add-Ons					Total Due: \$	
	QTY	Discount Rate	Standard Rate	QTY	24-Hour Service	QTY	Overhead Service*	QTY		Combined 24-hour & Overhead*
208V Single Phase 30 Amp		\$360.00	\$450.00		+50% rate		\$450.00		\$675.00	
208V Single Phase 60 Amp		\$685.00	\$855.00		+50% rate		\$855.00		\$1,282.50	
208V Single Phase 100 Amp		\$1,050.00	\$1,310.00		+50% rate		\$1,310.00		\$1,965.00	
208V Three Phase 30 Amp		\$650.00	\$810.00		+50% rate		\$810.00		\$1,215.00	
208V Three Phase 60 Amp		\$980.00	\$1,225.00		+50% rate		\$1,225.00		\$1,837.50	
208V Three Phase 100 Amp		\$1,555.00	\$1,945.00		+50% rate		\$1,945.00		\$2,917.50	
208V Three Phase 200 Amp		\$2,965.00	\$3,710.00		+50% rate		\$3,710.00		\$5,565.00	
208V Three Phase 400 Amp		\$5,240.00	\$6,550.00		+50% rate		\$6,550.00		\$9,825.00	
480V Three Phase 30 Amp		\$990.00	\$1,235.00		+50% rate		\$1,235.00		\$1,852.50	
480V Three Phase 60 Amp		\$1,715.00	\$2,145.00		+50% rate		\$2,145.00		\$3,217.50	
480V Three Phase 100 Amp		\$3,165.00	\$3,960.00		+50% rate		\$3,960.00		\$5,940.00	
480V Three Phase 200 Amp		\$6,290.00	\$7,865.00		+50% rate		\$7,865.00		\$11,797.50	
25' Round Extension Cord		\$36.00	\$45.00							
6 Port Power Strip			\$25.00							

**Total Due: \$**

SIGNATURE \_\_\_\_\_

To pay with a Discover, MasterCard, Visa or American Express, you may order online at [www.signatureboston.com](http://www.signatureboston.com).

To pay with a check, send a check payable to Massachusetts Convention Center Authority and this form to:

EXHIBITOR SERVICE CENTER | MASSACHUSETTS CONVENTION CENTER AUTHORITY | 415 SUMMER STREET | BOSTON, MASSACHUSETTS 02210  
 617.954.2230 [EXHIBITORSERVICES@SIGNATUREBOSTON.COM](mailto:EXHIBITORSERVICES@SIGNATUREBOSTON.COM) TAX ID#: 042768982

**FOR MCCA USE ONLY**

Date Received:	Received by:	Check Number:	Discover/MC/Visa/Amex:
----------------	--------------	---------------	------------------------

**Exhibitor Order Form  
Telephone Services**

Effective January 1, 2019

By submitting this order form, Exhibitor acknowledges and accepts all Policies, Terms & Conditions for service as set forth in the MCCA Exhibitor Ordering Guide available at <http://www.signatureboston.com/bcec/bcec-ordering-guide.aspx>.  
**To qualify for discount rate, request and payment must be received 21 days prior to show/event opening.**

*Incomplete information will delay processing.*

Event or Show:		Booth no. (s)		
Event or show date(s):		Exhibiting firm:		
Billing address:	City:	State:	Zip:	Country:
Phone:		Email:		
Ordered by/title:		Show site contact:		
Date:		Contact phone:		

STANDARD TELEPHONE SERVICES	QTY	DISCOUNT RATE	STANDARD RATE	TOTAL DUE: \$
Single Line Phone Service (Analog)		\$295.00	\$365.00	
Multi-Line Phone Service (Digital)		\$425.00	\$530.00	
Speaker Phone Service (Analog)		\$325.00	\$410.00	
Polycom Speaker Phone Service (Analog)		\$380.00	\$475.00	

ADDITIONAL TELEPHONE SERVICES & EQUIPMENT	QTY	DISCOUNT RATE	STANDARD RATE	TOTAL DUE: \$
Call Waiting (Per Phone Line)		\$50.00	\$65.00	
Voice Mail (Per Phone Line)		\$50.00	\$65.00	
ISDN/BRI Service		\$305.00	\$385.00	
Polycom Video Conference Equipment Rental w/ IP Connect Service		\$2,040.00	\$2,550.00	
Polycom Video Conference Equipment Rental w/ ISDN Service		\$1,120.00	\$1,630.00	
				<b>Total Due: \$</b>

SIGNATURE \_\_\_\_\_

 To pay with a Discover, MasterCard, Visa or American Express, you may order online at [www.signatureboston.com](http://www.signatureboston.com).

To pay with a check, send a check payable to Massachusetts Convention Center Authority and this form to:

 EXHIBITOR SERVICE CENTER | MASSACHUSETTS CONVENTION CENTER AUTHORITY | 415 SUMMER STREET | BOSTON, MASSACHUSETTS 02210  
 617.954.2230 [EXHIBITORSERVICES@SIGNATUREBOSTON.COM](mailto:EXHIBITORSERVICES@SIGNATUREBOSTON.COM) TAX ID#: 042768982

FOR MCCA USE ONLY			
Date Received:	Received by:	Check Number:	Discover/MC/Visa/Amex:



## Exhibitor Order Form Internet & Technical Services

Effective January 1, 2019

By submitting this order form, Exhibitor acknowledges and accepts all Policies, Terms & Conditions for service as set forth in the MCCA Exhibitor Ordering Guide available at <http://www.signatureboston.com/bcec/bcec-ordering-guide.aspx>.  
**To qualify for discount rate, request and payment must be received 21 days prior to show/event opening.**

*Incomplete information will delay processing.*

Event or Show:		Booth no. (s)		
Event or show date(s):		Exhibiting firm:		
Billing address:	City:	State:	Zip:	Country:
Phone:		Email:		
Ordered by/title:		Show site contact:		
Date:		Contact phone:		

WIRED INTERNET CONNECTIONS: MANUAL CONFIGURATION	QTY	DISCOUNT RATE	STANDARD RATE	TOTAL DUE: \$
<b>Basic Service Package</b> (includes a private VLAN and subnet, public IP addresses not available)		\$955.00	\$1,020.00	
<b>1.54 Mbps Managed Service</b> (includes a private VLAN and subnet, public IP addresses available upon request)		\$1,935.00	\$2,295.00	
<b>3 Mbps Managed Service</b> (includes a private VLAN and subnet, public IP addresses available upon request)		\$4,710.00	\$5,405.00	
<b>6 Mbps Managed Service</b> (includes a private VLAN and subnet, public IP addresses available upon request)		\$7,965.00	\$9,180.00	
<b>10 Mbps Managed Service</b> (includes a private VLAN and subnet, public IP addresses available upon request)		\$10,660.00	\$12,240.00	
<b>15 Mbps Managed Service</b> (includes a private VLAN and subnet, public IP addresses available upon request)		\$15,710.00	\$18,055.00	
<b>20 Mbps Managed Service</b> (includes a private VLAN and subnet, public IP addresses available upon request)		\$20,870.00	\$24,000.00	
<b>25 Mbps Managed Service</b> (includes a private VLAN and subnet, public IP addresses available upon request)		\$25,920.00	\$29,835.00	
<b>30 Mbps Managed Service</b> (includes a private VLAN and subnet, public IP addresses available upon request)		\$30,855.00	\$35,495.00	
<b>35 Mbps Managed Service</b> (includes a private VLAN and subnet, public IP addresses available upon request)		\$35,905.00	\$41,310.00	
<b>40 Mbps Managed Service</b> (includes a private VLAN and subnet, public IP addresses available upon request)		\$40,615.00	\$46,715.00	

CONTINUED ON PAGE 25

ADDITIONAL SERVICES & EQUIPMENT		QTY	DISCOUNT RATE	STANDARD RATE	TOTAL DUE: \$
Copper Patch / Booth to Booth Connection			\$345.00	\$430.00	
Fiber Patch/ Booth to Booth Connection			\$480.00	\$600.00	
Switch	8 port		\$105.00	\$135.00	
	24 port		\$360.00	\$455.00	
25' CAT 5e Cable			\$46.00	\$57.00	
50' CAT 5e Cable			\$62.00	\$80.00	
100' CAT 5e Cable			\$100.00	\$120.00	
Coupler			\$15.00	\$20.00	

TECHNICAL SERVICES		QTY	DISCOUNT RATE	STANDARD RATE	TOTAL DUE: \$
Cable TV Service			\$250.00	\$315.00	
CATV Tuner Rental (Only available at the BCEC)			\$57.00	\$72.00	
CATV Tap Box			\$205.00	\$255.00	
					Total Due: \$

SIGNATURE \_\_\_\_\_

To pay with a Discover, MasterCard, Visa or American Express, you may order online at [www.signatureboston.com](http://www.signatureboston.com).  
 To pay with a check, send a check payable to Massachusetts Convention Center Authority and this form to:

EXHIBITOR SERVICE CENTER | MASSACHUSETTS CONVENTION CENTER AUTHORITY | 415 SUMMER STREET | BOSTON, MASSACHUSETTS 02210  
 617.954.2230 [EXHIBITORSERVICES@SIGNATUREBOSTON.COM](mailto:EXHIBITORSERVICES@SIGNATUREBOSTON.COM) TAX ID#: 042768982

FOR MCCA USE ONLY			
Date Received:	Received by:	Check Number:	Discover/MC/Visa/Amex:

**Exhibitor Order Form  
Rigging Services**

Effective January 1, 2019

By submitting this order form, Exhibitor acknowledges and accepts all Policies, Terms & Conditions for service as set forth in the MCCA Exhibitor Ordering Guide available at <http://www.signatureboston.com/bcec/bcec-ordering-guide.aspx>.  
**To qualify for discount rate, request and payment must be received 21 days prior to show/event opening.**

*Incomplete information will delay processing.*

Event or Show:		Booth no. (s)		
Event or show date(s):		Exhibiting firm:		
Billing address:	City:	State:	Zip:	Country:
Phone:		Email:		
Ordered by/title:		Show site contact:		
Date:		Contact phone:		

**ITEM DESCRIPTION & INFORMATION**

\*\*Description of Item (Sign, Banner, Truss, etc.)

Quantity:	Size:	Weight:	Height desired from floor to top of suspended item:
Do any items require Electrical service (circle one)? <b>YES NO</b>		Indicate Service Ordered on Electrical Form:	
Date When Your Item Will Be Ready for Hanging:		Preferred Move-Out Date:	

**PACKAGE RIGGING SOLUTIONS**

Service Description	QTY	Discount Rate	Standard Rate	Total Due: \$
Basic Rigging Package (Per Sign/Banner)		\$1736.00	\$2083.00	
Electrical Rigging Package (Per Sign/Banner)		\$2009.00	\$2411.00	
Team Labor Hour		\$273.00	\$328.00	

**CUSTOM RIGGING SOLUTIONS - RIGGING EQUIPMENT RENTAL (REQUIRES QUOTE\*)**

\*For any of the services below, please contact JCALPRO at 617.954.2345.

Equipment Description	QTY	Discount Rate	Standard Rate	Total Due: \$
Silver 12" x 12" Box Truss	5' Section	\$28.00	\$34.00	
	8' Section	\$45.00	\$54.00	
	10' Section	\$56.00	\$67.00	
Black 12" x 12" Box Truss	5' Section	\$39.00	\$47.00	
	8' Section	\$63.00	\$75.00	
	10' Section	\$78.00	\$94.00	
Silver 20.5" x 20.5" Box Truss	5' Section	\$50.00	\$60.00	
	8' Section	\$81.00	\$97.00	
	10' Section	\$101.00	\$121.00	
Corner Block	Silver 12" x 12" box	\$56.00	\$67.00	
	Black 12" x 12" box	\$73.00	\$87.00	
	Silver 20.5" x 20.5" box	\$78.00	\$94.00	
Base Plate		\$39.00	\$47.00	
Rotator		\$168.00	\$202.00	
Motor		\$168.00	\$202.00	
Cheeseboro		\$7.00	\$8.00	
Grapple		\$13.00	\$16.00	

CONTINUED ON PAGE 29

CUSTOM LIGHTING SOLUTIONS – LIGHTING EQUIPMENT RENTAL (REQUIRES QUOTE*)				
*For any of the services below, please contact JCALPRO at 617.954.2345.				
Lighting Fixtures	QTY	Discount Rate	Standard Rate	Total Due: \$
Source 4 Par – (575 watt, 750 watt)		\$39.00	\$47.00	
Source 4 Leko – (575, 750 watt)		\$50.00	\$60.00	
Par 64 (1000 watt)		\$34.00	\$40.00	
Lighting Kits	QTY	Discount Rate	Standard Rate	Total Due: \$
Small Lighting Kit		\$207.00	\$249.00	
Medium Lighting Kit		\$364.00	\$437.00	
Large Lighting Kit		\$504.00	\$605.00	
X-Large Lighting Kit		\$616.00	\$739.00	
Dimmer Racks & Lighting Controls	QTY	Discount Rate	Standard Rate	Total Due: \$
Dimmer Control 1.2 x 4		\$90.00	\$108.00	
Dimmer Control 2.4 x 12		\$168.00	\$202.00	
Dimmer Control 2.4 x 24		\$358.00	\$430.00	
<b>Total Due: \$</b>				

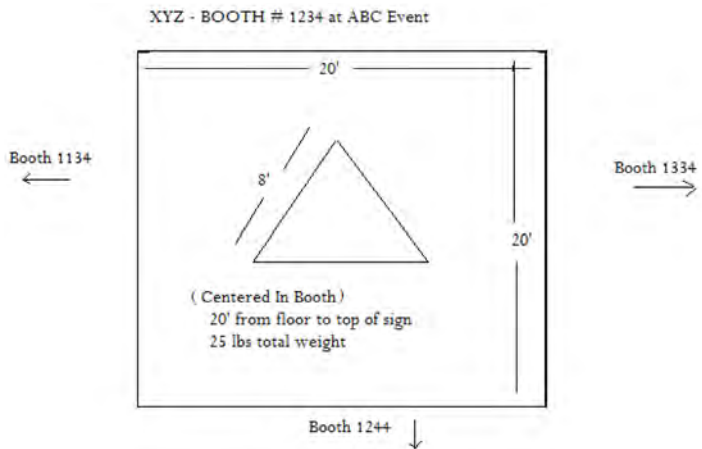

We require diagrams and booth layouts for all rigging and lighting orders. See sample on left.

**SIGNATURE**

---

To pay with a Discover, MasterCard, Visa or American Express, you may order online at [www.signatureboston.com](http://www.signatureboston.com).  
 To pay with a check, send a check payable to Massachusetts Convention Center Authority and this form to:

EXHIBITOR SERVICE CENTER | MASSACHUSETTS CONVENTION CENTER AUTHORITY | 415 SUMMER STREET | BOSTON, MASSACHUSETTS 02210  
 617.954.2230 [EXHIBITORSERVICES@SIGNATUREBOSTON.COM](mailto:EXHIBITORSERVICES@SIGNATUREBOSTON.COM) TAX ID#: 042768982

FOR MCCA USE ONLY			
Date Received:	Received by:	Check Number:	Discover/MC/Visa/Amex:

**Exhibitor Order Form  
Plumbing Services**

Effective January 1, 2019

By submitting this order form, Exhibitor acknowledges and accepts all Policies, Terms & Conditions for service as set forth in the MCCA Exhibitor Ordering Guide available at <http://www.signatureboston.com/bcec/bcec-ordering-guide.aspx>.  
**To qualify for discount rate, request and payment must be received 21 days prior to show/event opening.**

*Incomplete information will delay processing.*

Event or Show:		Booth no. (s)			
Event or show date(s):		Exhibiting firm:			
Billing address:	City:	State:	Zip:	Country:	
Phone:		Email:			
Ordered by/title:		Show site contact:			
Date:		Contact phone:			

**WATER AND DRAIN SERVICES**

Service	Description	QTY	Size	Discount Rate	Standard Rate	Total Due: \$
Water Approx 75 PSI Up to ¾" line	Individual Connection			\$335.00	\$420.00	
	Additional Connection			\$195.00	\$245.00	
Drain Up to ¾" line	Individual Connection			\$335.00	\$420.00	
	Additional Connection			\$180.00	\$225.00	
Fill & Drain	0-100 Gallons			\$170.00	\$210.00	
	Each additional 500 gallons			\$115.00	\$145.00	

**SINK RENTALS**

Service	Description	QTY	Size	Discount Rate	Standard Rate	Total Due: \$
Cold Water Sink Rental	Includes: sink, one water and one drain connection			\$675.00	\$840.00	
Small Hot & Cold Water Sink Rental	Includes: sink, hot water heater (6 gallon cap.), dedicated power, 2 water and one drain connection			\$900.00	\$1,120.00	
Large Hot & Cold Water Sink Rental	Includes: 3-tub basin, hot water heater (6 gallon cap.), dedicated power, 2 water and one drain connection			\$1,120.00	\$1,405.00	

**COMPRESSED AIR AND GASSES\***

Service	Description	QTY	Size	Discount Rate	Standard Rate	Total Due: \$
Air Approx 110 PSI	Individual Connection			\$410.00	\$510.00	
	Additional Connection			\$210.00	\$265.00	
CO2	20 lb Cylinder (Dry or Liquid)			\$170.00	\$205.00	
	50 lb Cylinder (Dry or Liquid)			\$190.00	\$225.00	
Nitrogen	300 ft3 Tank (Dry)			\$230.00	\$280.00	

SIGNATURE \_\_\_\_\_

Total Due: \$

 To pay with a Discover, MasterCard, Visa or American Express, you may order online at [www.signatureboston.com](http://www.signatureboston.com).

To pay with a check, send a check payable to Massachusetts Convention Center Authority and this form to:

 EXHIBITOR SERVICE CENTER | MASSACHUSETTS CONVENTION CENTER AUTHORITY | 415 SUMMER STREET | BOSTON, MASSACHUSETTS 02210  
 617.954.2230 [EXHIBITORSERVICES@SIGNATUREBOSTON.COM](mailto:EXHIBITORSERVICES@SIGNATUREBOSTON.COM) TAX ID#: 042768982

**FOR MCCA USE ONLY**

Date Received:	Received by:	Check Number:	Discover/MC/Visa/Amex:
----------------	--------------	---------------	------------------------

**Exhibitor Order Form  
Security Services**

Effective January 1, 2019

By submitting this order form, Exhibitor acknowledges and accepts all Policies, Terms & Conditions for service as set forth in the MCCA Exhibitor Ordering Guide available at <http://www.signatureboston.com/bcec/bcec-ordering-guide.aspx>.  
**To qualify for discount rate, request and payment must be received 21 days prior to show/event opening.**

*Incomplete information will delay processing.*

Event or Show:		Booth no. (s)			
Event or show date(s):		Exhibiting firm:			
Billing address:	City:	State:	Zip:	Country:	
Phone:		Email:			
Ordered by/title:		Show site contact:			
Date:		Contact phone:			

SECURITY SERVICES						
Date	# Of Officers	Scheduled hrs. (4 hr. min.)	Total Man hrs.	Discount Rate (per man hrs.)	Standard Rate (per man hrs.)	Total Due: \$
				\$28.00	\$33.50	
				\$28.00	\$33.50	
				\$28.00	\$33.50	
				\$28.00	\$33.50	
				\$28.00	\$33.50	
				\$28.00	\$33.50	
				\$28.00	\$33.50	
				\$28.00	\$33.50	
				\$28.00	\$33.50	
				\$28.00	\$33.50	
				\$28.00	\$33.50	
				\$28.00	\$33.50	
				\$28.00	\$33.50	
				\$28.00	\$33.50	
			<b>Total Man Hours:</b>			<b>Total Due: \$</b>

SIGNATURE \_\_\_\_\_

 To pay with a Discover, MasterCard, Visa or American Express, you may order online at [www.signatureboston.com](http://www.signatureboston.com).

To pay with a check, send a check payable to Massachusetts Convention Center Authority and this form to:

 EXHIBITOR SERVICE CENTER | MASSACHUSETTS CONVENTION CENTER AUTHORITY | 415 SUMMER STREET | BOSTON, MASSACHUSETTS 02210  
 617.954.2230 [EXHIBITORSERVICES@SIGNATUREBOSTON.COM](mailto:EXHIBITORSERVICES@SIGNATUREBOSTON.COM) TAX ID#: 042768982

FOR MCCA USE ONLY			
Date Received:	Received by:	Check Number:	Discover/MC/Visa/Amex:

# Exhibitor Guidelines, Information and Regulations

## EXHIBITOR PARTICIPATION REGULATIONS

### ACCESS CONTROL AND CREDENTIALING

Exhibitors accessing the BCEC – including exhibitors traveling to the BCEC, unloading exhibitor-related cargo and parking at the BCEC – must be credentialed by the BCEC Public Safety Department before entering the facility. Issued Exhibitor Credentials must be worn on the outermost garment (or on the right wrist if an ID band is issued) of the exhibitor (employees and contractors) at all times while inside the facility.

Exhibitors should check in with the General Service Contractor (GSC) Marshalling Lot Trailer, or go directly to the South Parking Lot if directed by the GSC or Licensee, before proceeding into the building at Southwest Badging. Upon request and as a requirement to be issued a MCCA ID, all employees and contractors working within an MCCA facility must identify themselves with a current and valid, government-issued photo identification (preferably a valid state-issued motor vehicle operator's license). Once positively identified by MCCA Public Safety, the exhibitor will be referred to the Licensee in order to register and receive event credentials.

ESCA identification badges are required for all General Service Contractors (GSC). Temporary MCCA credentials will not be issued to GSC employees and they will be turned away.

Lost/missing credentials must be reported to, and recorded by, MCCA Public Safety. The MCCA, in its sole discretion, reserves the right to revoke credentials for violations of law, facility policies and procedures, and/or injuries against persons or property, and/or when the revocation of those credentials is in the best interests of the MCCA.

### AFFIXING TO THE FACILITY STRUCTURE

The MCCA does not allow exhibitors to:

- Rig cable/hanging devices or affix any materials to the ceiling, electrical buss ducts and conduits, sprinkler pipes, ventilation equipment, windows, columns or any other physical structure at the BCEC
- Cause or permit any nails, staples, hooks, tacks, screws, or the like to be driven into the facility structure (including, but not limited to, any wall, ceiling, column, stone, window, drape, painted, carpeted or concrete surfaces of the premises)
- Erect any decorations or use adhesive materials, including tape that can deface the walls, ceilings, floors, facilities and equipment contained on the premises
- Paint or permanently cover walls, floors, ceilings, or other areas of the facility or its furnishings or fixtures

### BOOTH SET-UP AND DISMANTLE

The unpacking, assembling, dismantling and packing of displays and equipment may be done by full-time employees of an exhibiting company. Exhibitors are allowed to set-up and/or dismantle their own booths, provided that they use their own bona fide, full-time employees. It is acceptable for exhibitors to safely use power tools to set-up and/or dismantle their own booths.

No one under the age of 18 is permitted on the loading docks, in truck bays or in the loading dock yard. Additionally, no one under the age of 18 is permitted in the exhibit halls during move-in or move-out operations. The Licensee will determine age restrictions, if any, for hours when the exhibit hall is open for attendees.

## BOOTH STAGING

1. In addition to equipment and furniture placed within a booth space, subject to show management limitations, exhibitors are allowed to stage the following items:
  - a. Boxed or loose product, materials or literature
  - b. Fiber cases used to ship pop-up displays
  - c. Personal items such as luggage, purses, briefcases or coats
2. The following restrictions must be observed when staging these additional items:
  - a. The amount of product, materials or literature that may be staged within a booth space must not exceed a one-day supply.
  - b. Items may be placed either in a display case, on a counter, on a shelving unit, in a closet, on a table, under a table or stacked neatly within the booth space.
  - c. Items that are stacked must not create a tripping hazard or hamper easy movement within the booth space.
  - d. Items may not be placed on or within six inches of floor ports, electrical wiring or cabling.
  - e. Pallets, empty crates, cartons and boxes may not be stored in the booth space.
  - f. Staging will not be allowed behind the back wall of the booth and behind the drape within the booth or exhibit area.

## CABLING

No cables (telephone, Internet, electrical, audio, video, etc.) should be run in front of any doorways at any time. If cables must cross a doorway, cables must be flown — cable trays are not an acceptable substitute.

## CANDLES

Candles are not permitted.

## CAUTION TAPE

Use of 'Caution Tape' is prohibited. Yellow or red plastic tape with black stripes, or printed with 'Caution,' 'Do Not Enter' or other warning messages may only be placed by the MCCA to warn individuals of a hazardous condition. The MCCA prohibits the use of yellow or red plastic tape to restrict access to an event or exhibit display. Rope and stanchion is available from the General Service Contractor.

## COOKING DEMONSTRATIONS

If cooking or heating appliances will be used, the MCCA prefers they are powered by electricity, use UL listed/approved equipment and be adequately ventilated.

An exhibitor may use butane for cooking purposes with prior approval of the MCCA Public Safety Department. Quantity inside the facility is limited to: two (2) 1-pound UL listed/approved non-refillable canisters per cooking device; one canister attached to the cooking device; and one spare canister. To prevent excessive amounts of butane within the facility, exhibitors may only use butane canisters purchased directly through the MCCA's exclusive food provider, Levy Restaurants.

Single-well cooking equipment (deep fryer type device) using combustible oils and solids shall:

1. Have lids available for immediate use
2. Be limited to 288 sq. in. (.19 sq. m) of cooking surface
3. Be placed in noncombustible surface materials
4. Be separated from each other by a minimum horizontal distance of 2 ft. (61 cm); multiple single-well cooking units may be placed together if the aggregate cooking surface does not exceed 288 sq. in. (.19 sq. m)
5. Be kept a minimum horizontal distance of 2 ft. (61 cm) from any combustible material

Exhibitor must provide a UL listed/approved fire extinguisher no less than 30 feet (9.15 meters) from the cooking device.

Exhibitor shall provide a 6 liter, Class K fire extinguisher for hazards where there is a potential for fires involving combustible cooking media (vegetable oils, animal oils or fats in cooking appliances) for each device.

Fire extinguishers must be mounted in a visible location and accessible at all times. All extinguishers shall be currently inspected and tagged by a licensed fire extinguisher company.

Open flames, cooking or other sources of heat are prohibited under any tent, canopy or tarp.

### EXCLUSIVE SERVICES

The MCCA will be the exclusive provider of the following services: food & beverage, electrical, business center, telephone, Internet, rigging, the operation of ground-supported crank-ups, the operation and provision of lifts for theatrical purposes, plumbing, the use of the house sound system, and the supply of compressed airs and gases.

The MCCA is the preferred provider of security booth coverage for exhibitors. If your event designates another security vendor for booth coverage, you may choose to order through the event's preferred provider as detailed in your exhibitor kit.

### EXHIBITOR PRODUCT

Exhibitors are prohibited from offering or selling any product(s) to any employee, agent, contractor or subcontractor working at the MCCA.

At the conclusion of the event, all products must be either:

- Removed from MCCA facilities by the exhibitor;
- Properly disposed of;
- Donated to a previously identified nonprofit organization; or
- Sold to an established business, with sales receipts supplied and produced on demand.

Any MCCA employee, agent, contractor or subcontractor working in MCCA facilities who is determined to be removing and/or accepting event-related product(s) is subject to immediate termination of employment or prohibition from working at all MCCA facilities.

*All persons, vehicles, bags, containers, etc. are subject to search.*

### FIRE SAFETY REGULATIONS

Exhibits and decorative materials must meet the requirements of the Code of Massachusetts Regulations – 780 CMR EIGHT EDITION (Building Code). The Massachusetts Department of Public Safety (DPS) has jurisdiction over all safety matters of the MCCA. The DPS, in conjunction with the City of Boston Fire Department (BFD), provide guidance to the MCCA for a safe venue for all guests and employees at our facilities.

Prior to the show opening or at any time during the event, the MCCA Public Safety Department or other agency may inspect booths and other assembly areas to ensure these requirements are met. If they are not, adjustments can be costly – if a display is determined to be a hazard it may be ordered removed from the facility at the exhibitor's expense.

These requirements shall apply whether the event is open or closed to the public. The below topics are the minimum fire safety requirements for all events and are designed to provide an overview; the MCCA Public Safety Department reserves the right to make any final decision for life safety issues. Our sole effort is to ensure the success of your event and safeguard the safety and experience of all our visitors.

### FIRE SAFETY LIMITATIONS

The following limitations apply to all exhibits located in the exhibition halls in the BCEC:

1. The following items are fire hazards and are prohibited for use in the BCEC:
  - a. Compressed flammable gases. Exception: Butane for cooking purposes with prior approval of the MCCA Public Safety Department (see Cooking Demonstrations)
  - b. Pyrotechnics, flammable/combustible liquids, hazardous chemicals/materials, blasting agents and explosives
  - c. Cut Christmas trees, cut evergreens or similar trees
  - d. Fireplace logs, charcoal and similar materials
  - e. Untreated mulch and Spanish moss or similar vegetation
  - f. Untreated hay or straw
2. Any interior finish, either permanent or temporary, will be required to meet the requirements of the Code of Massachusetts Regulations – 780 CMR EIGHT EDITION (Building Code).
3. The following rules apply regarding flame-retardant treatments:
  - a. All curtains, drapes, banners, decorations and acoustical material (including but not limited to cotton, hay, paper, straw, moss, split bamboo and wood chips) must be flame-retardant treated to the satisfaction of the Massachusetts Department of Public Safety. Material that cannot be treated for flame retardancy shall not be

used. The GSC or individual exhibitor must have on-site a copy of the Certificate of Flame Resistance for all floor covering, curtains and rigged signage. The use of carpet on walls, ceilings, seating products or as decorative material is prohibited.

- b. Combustible materials, an inch or more in thickness, glass or asbestos cloth may be used without flame-retardant treatment.
  - c. The use of oilcloth, tarpaper, sisal paper, nylon, Orlon®, and certain other plastic materials that are not flame-retardant is prohibited.
4. Open flame devices may be permitted when they are a necessary part of the exhibit, with prior approval of the MCCA Public Safety Department. Devices must be isolated from attendees by either four (4) feet or a barrier; be placed on a non-combustible surface; be separated from other devices by five (5) horizontal feet; and have a 10 lb. ABC fire extinguisher present within the exhibit. Fire extinguishers must be mounted in a visible location and be accessible at all times. All extinguishers shall be currently inspected and tagged by a licensed fire extinguisher company.
  5. The hanging or rigging of signs, displays or banners, etc. shall not interfere with the building fire sprinkler system.
  6. Exhibitors are prohibited from covering displays with drop cloths, sheets, table cloths or other non-flame resistant material.
  7. Storage of combustible materials in meeting rooms, ballrooms or service corridors is prohibited.
  8. Exhibitors shall move, remove or arrange with the General Service Contractor to remove wooden pallets, shipping crates, cardboard boxes and other packing materials from the exhibit hall area as soon as possible. These items are not permitted in the exhibit halls during events. See Booth Staging.

#### EXHIBIT HALL LIFE SAFETY EQUIPMENT

Fire extinguishers are located on each of the support columns in the exhibit hall area and on the perimeter walls. All brackets are 40 inches (102 cm) from the floor. Support column fire extinguishers are primarily mounted on the northwest quadrant. Fire extinguishers on the support columns along the north end of Hall A, and those on the south side of the air walls, are mounted on the southwest quadrant. General Service Contractors (GSC) and exhibitors are required to

maintain a minimum unobstructed path of no less than 48 inches (122 cm), 24 inches (61 cm) on center for fire extinguishers.

Fire extinguishers shall not be removed or temporarily relocated by any exhibitor, the Licensee or the GSC. The GSC is responsible for ensuring that egress paths, emergency exits, fire extinguishers, fire pull stations, fire department value boxes, fire alarm flashers and AEDs are not obstructed or obscured from view at any time in the facility. Anyone found responsible for moving, removing or blocking fire safety equipment is subject to a fine.

#### FLAME-RETARDANT TREATED MATERIALS

The following rules apply regarding flame-retardant treatments:

1. All decorations, drapes, signs, banners, acoustical materials, hay, straw, moss, split bamboo, plastic cloth, and similar decorative materials shall be flame-retardant to the satisfaction of the Boston Fire Department and State Fire Marshal.
2. Combustible materials, 3/8 inch or more in thickness, glass or asbestos cloth may be used without flame-retardant treatment.
3. The use of oilcloth, tarpaper, sisal paper, nylon, Orlon®, and certain other plastic materials that are not flame-retardant, is prohibited.
4. Table coverings used in exhibit halls must be flame-retardant treated, unless they lie flat, and have an overhang of no more than six (6) inches.
5. All materials must be certified by the Boston Fire Department within six (6) months of the event. The Boston Fire Department does not accept certificates from other jurisdictions. Materials may be sent directly to the Boston Fire Department for testing.
6. The City of Boston Fire Code prohibits the use of:
  - Fabric attached to a ceiling or used to cover any portion of an exhibit
  - Carpet on ceilings, walls, seating products, or as decorative material

## LASERS

The use of lasers for exhibit demonstrations or visual effects for entertainment must be approved by the Licensee and the MCCA Public Safety Department. All lasers must comply with Code of Massachusetts Regulations 105 CMR 120.000, and be registered and approved by the Massachusetts Department of Public Health. Regulations and applications are available from the Massachusetts Department of Public Health.

## FOOD & BEVERAGE SAMPLES

The MCCA prohibits any food or beverages from being brought into the building, except by Levy Restaurants, the exclusive food & beverage service provider. The distribution of food and beverages, regardless of type and/or quantity, is the sole responsibility of Levy Restaurants.

Levy Restaurants is the official caterer for all food and beverage services within the BCEC. All arrangements for the service of food and/or beverages must be made through the catering office. Food and beverage sampling in conjunction with specific exhibits may be permitted, but only to the extent approved in writing, in advance, by a Levy Restaurants Catering Sales Manager.

In order to obtain authorization from your Catering Sales Manager to distribute food and beverage items, one of the following conditions must exist:

- (1) The party interested in distributing food and/or beverage must be the manufacturer of said product. The interested party must only distribute sample sizes (2 ounces of pre-packaged food items or 4 ounces of non-alcoholic beverages) of his/her product, and cannot participate in cash sales of said product during the show.

-OR-

- (2) The party interested in distributing food and/or beverage items must pay a fee, which is based on a percentage of retail pricing for the item and is subject to all applicable administrative fees and taxes, in order to waive its right to exclusivity under the MCCA/BCEC License Agreement.

If a party brings unauthorized food and/or beverage items into the BCEC and does not subsequently meet one of the conditions listed above, the party must immediately remove the unauthorized item(s) from their exhibit or meeting space.

## Temporary Food Service Permit Application

The City of Boston Inspectional Services Division requires a temporary food service permit for any food & beverage served at the BCEC that is not sourced through Levy Restaurants. Permit fees begin at \$30.00 for a one-day permit, with \$5.00 for each additional day of sampling (example: a 3-day permit costs \$40.00).

## GLITTER, CONFETTI, POPCORN AND OTHER MATERIALS

The use of glitter, confetti, sand, popcorn or simulated snow types of material is not permitted in the BCEC. Additionally, adhesive-backed decals may not be given away or utilized.

## GRATUITIES POLICY

It is against the MCCA's policy for any employee or service contractor to accept gratuities or gifts from the Licensee and/or any exhibitors. Offering of tips and gratuities to personnel employed by the MCCA, or its contractors, agents or suppliers, is not necessary and strictly prohibited. If you are approached or solicited by any MCCA or service contractor personnel for gratuities, please report this violation to the Chief of Public Safety at 617.954.2222.

## GUARDRAILS AND STAIRS

Any platforms exceeding 30" in height will require a Massachusetts State building code compliant guardrail system. The guardrail shall be 42" in height, with balusters or solid material such that a sphere with a four-inch (4") diameter cannot pass through any opening.

The guardrails shall not have an ornamental pattern that would provide a ladder effect. This includes a guardrail on stairs.

The guardrail system shall be capable of withstanding a load of 200 pounds (minimum).

Stair construction shall meet Massachusetts State building code for riser height of 7" maximum and a tread depth of 11" minimum. These stairs shall have a handrail that shall be continuous, without interruption by newel posts, other

structure elements or obstructions. Handrails shall not be less than 34” or more than 38”. The handrail ends shall be returned to a wall or post. All stairway handrails shall have a circular cross section with an outside diameter of at least 1-1/4” and not greater than 2”.

Stair width shall be a minimum of 36”. Many multi-level displays are designed without risers, which is not permitted by the Massachusetts State building code as the stairway is part of a means of egress. The easiest way to address this issue with minimal cost is to secure a fitted piece of fire-rated plywood or sheet rock between the stringers against the back of the treads.

### HAND-CARRY POLICY

The MCCA reserves the right to restrict all freight and package deliveries to the loading dock. MCCA Public Safety personnel will be on site to direct and assist exhibitors during move-in and move-out.

For the convenience and safety of exhibitors and patrons, all freight and material handling must enter and exit the facility through the loading dock. The Licensee and its exhibitors will be allowed to hand carry one item, one time, in or out of the facility without having to access the loading dock. (Hand-carried freight is defined as one item that can be easily carried by an individual, without the need for dollies or other mechanized equipment.)

No parking is allowed at the entrance of the facility, and the use of passenger elevators for movement of freight is not allowed. All packages are subject to inspection by facility personnel.

This policy is strictly enforced at The Westin Boston Waterfront Hotel skybridge as well.

### LIGHTS

Only Underwriters Laboratories (UL) approved, clamp-on types of portable spotlights are allowed. All display lights must be turned off when the exhibitor leaves for the day. Only UL approved extension cords 12 gauge or greater, rated for 20 amp, are allowed. Note: Household extension cords are not permitted. These are generally 14 or 16 gauge and only rated at 15 amp.

## MATERIAL HANDLING

**Exhibitors are allowed to perform their own material handling, providing all of the following criteria are met:**

- Exhibit personnel performing the work must be bona fide, full-time employees (“authorized personnel”) of said company.
- Exhibitors may choose to off-load from a company-owned truck or rental vehicle, or from a car, van or truck owned by personnel of the company provided the vehicle is co-owned or rental vehicles must be less than 24 feet in length.
- Exhibitors may use only hand-operated equipment, which they have provided; two-wheeled hand trucks and four-wheeled flat trucks are permitted as well.
- At no time can vendors (A/V, furniture design firm, etc.) unload their items. An approved General Service Contractor (GSC) or the Exclusive Rigging Service Provider (ERSP) must be hired by the Licensee to unload/re-load and push in all vendors.

### MEANS OF EGRESS

The travel distance within an exhibit booth or exhibit enclosure (including temporary office/meeting spaces) to an exit access aisle shall not exceed 50 feet (15 meters). There should be a minimum of two (2) separate exits from any point in the hall or room where the occupant load is less than 500 persons. Where occupant loads are between 500 and 999 persons, there shall be a minimum of three (3) separate exit doors. Where occupant loads are 1,000 persons or greater, there shall be a minimum of four (4) separate exit doors.

Exits must be so located and exit access arranged so that exits are readily accessible at all times. Where more than one exit is required, exits must be remotely located from each other and arranged and constructed to minimize any possibility that more than one may be blocked by a fire or other emergency condition.

Where exits are not immediately accessible from an open floor area, safe and continuous unobstructed passageways, aisles or corridors leading directly to every exit must be maintained and arranged, to provide access for each occupant to at least two exits by separate ways of travel. At no time should an exit door or exit access door be locked, blocked or obstructed in a manner that will confuse or slow the movement of any people within the area. This requirement will also be in effect during the “move in” and “move out” of events.

During certain events, the total occupancy of larger meeting rooms and the ballrooms meeting room(s) being used may not require all the exit capacity provided for that area. In these cases, a special review will be done on the request to close some of the exit doors. An explanation, along with detailed drawings showing these doors, must be submitted for approval. If approved, the doors and exit signs must be covered to prevent any confusion to the occupants.

### MULTI-LEVEL BOOTHS AND CEILINGS/CANOPIES

#### Guidelines for Covered Exhibits With Less Than Three Hundred (300) Covered Square Feet

All materials used in the construction of covered exhibits and all decorative materials within the exhibit must be non-combustible or limited combustible (flame-retardant) materials. Certification of flame retardant treatment, along with samples of said materials, must be submitted, if requested by the MCCA Public Safety Department or the Massachusetts Department of Public Safety. It is strongly recommended that certifications of flame retardant treatments be available at show site to avoid on-site testing of materials.

Fabric must pass the NFPA-701 Code for flame spread and smoke development - Class A, Flame Spread less than or equal to 25, Smoke Developed less than or equal to 450. Canopies and tarps must be fire resistant and meet CPAI 84 (Canvas Products Association International) specifications. The original flame retardant compliance tag must be attached to tent, canopy or tarp.

The use of tents inside the Convention Center requires a special permit from the Massachusetts Department of Public Safety. Please contact the MCCA Public Safety Department at 617.954.2222 for assistance.

Exhibitor must install a single station and battery operated smoke detector on the interior of each covered exhibit or structure, including enclosed storage closets, regardless of the square footage. The detector must sound an audible alarm and be installed per the manufacturer's instructions.

Exhibitor must provide at least one (1) 10 lb. ABC, dry chemical fire extinguisher. Fire extinguishers must be mounted in a visible location and accessible at all times. All extinguishers shall be currently inspected and tagged by a licensed fire extinguisher company.

A single exhibit or group of exhibits with ceilings that do not require sprinklers shall be separated by a distance of not less than 10 feet (3050 mm) where the aggregate ceiling exceeds 300 square feet (28 square meters).

Open flame, cooking or other sources of heat are prohibited under any tent, canopy or tarp.

### MOVE-IN PROCEDURES

All exhibitor move-in is restricted to the BCEC Loading Dock. No exhibitor will be allowed access with his or her move-in materials via any other entrance to the facility. Please note the hand carry rule within the Exhibitor Participation Rules/General Conditions Section of the Event Guide.

### MULTI-LEVEL BOOTHS AND CEILINGS/CANOPIES

#### Guidelines for Multi-level Exhibits (regardless of the size) and Covered Exhibits With Larger Than Three Hundred (300) Covered Square Feet

Requests for construction of multi-level exhibits (regardless of the size) must be authorized by show management before being reviewed by the MCCA Engineering and Maintenance Division and MCCA Public Safety Department. To ensure the success of your exhibit, please read and comply with the following guidelines:

1. Plans should be submitted a minimum of 90 days before the move-in date of the event and must adhere to the following:
  - a. They must be scaled, signed and dated by a registered architect or professional engineer.
  - b. They must include the show name and dates.
  - c. They must include exhibitor's name and assigned booth number.
  - d. They must include directional information (i.e. indicate neighboring aisles and/or booth numbers).
  - e. They must indicate maximum exhibit height, within the booth. Height guidelines are established, per event, by show management.
  - f. They must include connection details for the elevated floor and stairs, and permitted loading for furnishings, storage units, work surfaces or occupants who will be permitted access to the upper level.
  - g. They must include a floor loading schedule that identifies the maximum safe floor loading, fixture loads (dead loads) and occupant loading (live loads), establishing what shall be the effective limits.
2. All materials used in the construction of multi-level and/or covered exhibits and all decorative materials within the exhibit must be non-combustible or limited combustible (flame-retardant) materials. If requested, certification of flame-retardant treatment, along with samples of said materials, must be submitted to the Massachusetts Department of Public Safety for testing. It is recommended that certifications of flame retardant treatments be available at show site.

CONTINUED FROM PREVIOUS PAGE

**MULTI-LEVEL BOOTHS AND CEILINGS/CANOPIES****Guidelines for Multi-level Exhibits (regardless of the size) and Covered Exhibits With Larger Than Three Hundred (300) Covered Square Feet**

3. Exhibits with an enclosed room or occupied second story must post notice at the bottom of the stairway, indicating maximum permitted occupancy (or total permitted weight load of the second level).
4. If second level is to be occupied and greater than three hundred (300) square feet, or is designed to hold 10 or more persons, two (2) stairways are required, remote from each other. If second level is to be occupied and less than three hundred (300) square feet, one (1) set of stairs is permitted.
  - a. Stair construction shall meet Massachusetts State building code for riser height of 7" maximum and a tread depth of 11" minimum.
  - b. These stairs shall have a handrail that shall be continuous, without interruption by newel posts, other structure elements or obstructions.
  - c. Handrails shall not be less than 34" or more than 38". The handrail ends shall be returned to a wall or post. All stairway handrails shall have a circular cross-section with an outside diameter of at least 1-1/4" and not greater than 2".
  - d. Stair width shall be a minimum of 36". Many multi-level displays are designed without risers, which is not permitted by the Massachusetts State building code as the stairway is part of a means of egress.
5. Individual areas of upper decks or covered areas must be limited to dimensions that do not exceed one thousand (1,000) square feet.
6. Exhibitor must install a single station and battery-operated smoke detector on the interior of each covered exhibit or structure, regardless of the square footage. The detector must sound an audible alarm and be installed per the manufacturer's instructions.
7. Exhibitor must provide a portable, dry chemical fire extinguisher for each level or each covered exhibit or structure. At least one (1) 10 lb. ABC portable type fire extinguisher must be provided for each three hundred (300) square feet. Fire extinguishers must be mounted in a visible location and accessible at all times. All extinguishers shall be currently inspected and tagged by a licensed fire extinguisher company.

**AUTOMATIC FIRE EXTINGUISHING SYSTEM**

1. The following shall be protected by an automatic extinguishing system:
  - a. Any home or house constructed within the exhibit hall; and it must also include smoke/fire alarms and a 10 lb. ABC fire extinguisher on each level
  - b. The lowest level of a multi-level exhibit, regardless of size, and/or a single-story covered exhibit where the covered area exceeds 300 sq. ft. (27.9 sq. m), and/or any covering over a multi-level exhibit exceeding 300 sq. ft. (27.9 sq. m)

*Exception: Exhibitors installing these approved flame retardant materials as coverings may avoid the need to install a fire extinguishing system:*

- A flame retardant material with fusible seams that under low temperatures (176° F / 80° C) will split and open the canopy to allow smoke to rise, activate sprinklers and allow water through the opening
- A flame retardant open mesh material with a minimum 70% opening
- Ceilings that are constructed of open grate design or listed dropout ceilings in accordance with NFPA 13, Standard for the Installation of Sprinkler Systems, shall not be considered ceilings within the context of this section
- Vehicles, boats and similar exhibited products having over 100 sq. ft. (9.3 sq. m) of roofed area shall be provided with smoke detectors (Single station and battery operated or portable smoke detectors meeting the requirements for Household Fire Warning Devices in NFPA 74 are acceptable.)

2. A temporary sprinkler system must be connected to the Convention Center's domestic water system. The MCCA maintains a list of approved, state-licensed fire sprinkler companies authorized to install temporary fire sprinkler systems. The vendor must submit a sprinkler coverage plan to the MCCA Engineering & Maintenance Department for approval.
3. To order a plumbing connection for the sprinkler system before you arrive, click on the "Exhibitor Online Ordering" link from the main MCCA Webpage ([www.massconvention.com](http://www.massconvention.com)).

4. Exhibitor must install at least one (1) single station and battery operated smoke detector on the interior of each covered exhibit or structure regardless of the square footage. The detector must have an audible alarm and be installed per the manufacturer's instructions.
5. Exhibitor must provide a portable, dry chemical fire extinguisher for each level or each covered exhibit or structure. At least one (1) 10 lb. ABC portable type fire extinguisher must be provided for each three hundred (300) square feet. Fire extinguishers must be mounted in a visible location, and be accessible at all times. All extinguishers shall be currently inspected and tagged by a licensed fire extinguisher company.

The Massachusetts Department of Public Safety does not permit the use of a fire watch ordered in lieu of a temporary fire sprinkler system as an alternative method for fire safety compliance.

### PROTECT YOUR EXHIBIT AND MATERIALS

The MCCA is not liable for, nor does the MCCA carry any insurance on, exhibitor property or fixtures. Please bear in mind that all of your exhibit material and displays are your property. Therefore, it is important that you take every precaution to protect this material. Below are some suggestions toward this end:

1. Ship your materials with a qualified carrier and be sure to lock trunks/crates.
2. If cartons are used, be sure that they are securely taped or banded and under no circumstances marked with the name or type of articles contained therein.
3. Be sure to furnish your shipping company with an accurate account and complete bill of lading.
4. Do not leave your booth unattended during the set-up period.
5. Do not leave exhibit material under tables or displays.
6. Do not include exhibit material in containers to be stored with empties.
7. At the close of the exhibit, be sure to pack as quickly as possible and under no circumstances leave your space unattended during this period.

8. If at all possible, have one of your staff remain in your space with your shipment, until it is actually picked up by the drayage contractor's personnel.
9. Promptly report any missing items or suspicious person(s) to Public Safety.

### SMOKING

The BCEC is a non-smoking facility. Smoking of any tobacco product or electronic cigarette ("e-cigarettes") is NOT allowed in the building at any time. Designated smoking areas are located outside the building.

### SOLICITATIONS

No solicitations or collections are permitted in the BCEC.

### VEHICLES AND OTHER MOTORIZED EQUIPMENT

Vehicles that are to be brought into the BCEC must be pre-approved. In some cases, vehicles will not be allowed in the building, and there are restricted areas that vehicles cannot enter. Keys to start the vehicle, as well as any deactivation codes for security features, must be left with the Public Safety Department.

Motorized vehicles are defined as any vehicle that is propelled by an internal combustion engine, such as, but not limited to: automobiles, trucks, buses, farm equipment, construction equipment, motorcycles, snow mobiles, aircraft, watercraft and lawnmowers.

*Motorized vehicles shall:*

1. Be equipped with a locking (or taped) gas cap to prevent the escape of vapors. Fuel tanks shall not have more than three (3) gallons of fuel, or 1/8 tank, whichever is less.
  - a. Exceptions:
    - i. Recreational vehicles (RVs) may have up to 1/4 tank of fuel
    - ii. Aircraft that is on standby status and is required to have a minimal fuel level as determined by the Federal Aviation Administration (FAA) such as MedFlight®
2. Have at least one (1) battery cable used to start the engine, disconnected and the end of the disconnected battery cable, taped. It is preferred that the positive or "hot" cable be disconnected.

3. Not be moved during exhibit hours. Vehicles may not be started or operated within the exhibit hall for the first 15 minutes after the exhibit hall closes to the public for the day or final closing of the event. No vehicle may be operated on the exhibit hall without a lead person walking in front of the vehicle warning people of vehicle movement.
4. Fueling or defueling of vehicles is prohibited.

## MCCA Services

The BCEC is the exclusive provider of the following services: food & beverage, business center, electrical, telephone, Internet, plumbing and the supply of compressed airs and gases, the use of the house sound system, rigging, the operation of ground-supported cranks-ups, and the operation and provision of lifts for theatrical purposes. Most of these services are available directly to an exhibitor and should be ordered through your Exhibitor Services Center. These exclusive services are subject to prices and conditions on appropriate order forms. Discounts may apply to some services by meeting the advance payment deadlines and conditions noted on the forms.

Exhibitors may order services through the Signature Boston Exhibitor Ordering Site at [www.signatureboston.com](http://www.signatureboston.com). For more information, Exhibitor Services can be contacted at 617.954.2230 or [exhibitorservices@signatureboston.com](mailto:exhibitorservices@signatureboston.com).

The MCCA is the preferred provider of security booth coverage for exhibitors. If your event designates another security vendor for booth coverage, you may choose to order through the event's preferred provider as detailed in your Exhibitor Kit.

## ATMS

Guests will find ATMs on Level One in the North Lobby and the Wicked Good Market, and on Level o East.

## AUDIO/VISUAL SERVICES

The BCEC offers in-house A/V services on a preferred basis, with a preferred audio/visual provider to help provide comprehensive event support and services. All types of audio and visual display devices, screens and computer interfaces are available, along with skilled operators. The BCEC features a digital audio system and extensive use of fiber optic cabling to distribute signals throughout the facility. The BCEC has a clear line of sight to all satellites and dedicated truck parking

spaces, complete with power and signal distribution. The preferred audio/visual provider is the exclusive provider for the use of the in-house sound systems. All other A/V companies must bring in a stand-alone speaker system.

## BOOTH PACKAGES

Services cannot be resold or bundled as a package without prior written approval.

## BUSINESS CENTER

The MCCA in-house vendor is the exclusive service provider of the Business Center. From simple documents to complex projects and on-going programs, the MCCA business center will provide document management solutions to meet your needs. The document solutions capabilities include: copying and digital printing, document production, supplies, computer services, electronic file submission, signage, custom printing services, document distribution, pack and ship options, express and ground service, fax service with delivery of incoming messages, and desktop/word processing.

## SATELLITE SERVICES

The BCEC has a clear line of sight to all satellites and convenient parking spots for uplink and downlink trucks. Power and signal distribution is available at all truck locations. Please contact Exhibitor Services for more details and pricing.

## Transportation

### PUBLIC TRANSPORTATION

We strongly encourage you to promote public transportation as an efficient option for your attendees and exhibitors. Public transportation in the Boston area is provided by the Massachusetts Bay Transportation Authority (MBTA or "The T"). A number of excellent public transportation options are available for service to and from the BCEC. South Station, the premier regional transportation center, is a ten-minute walk from the front door of the BCEC. Services available at South Station include the MBTA's Red and Silver lines, Amtrak regional service, bus service, and commuter rail.

### TAXI AND RIDESHARE INFORMATION

MMCCA staff will coordinate with the individual taxicab companies and the Boston Hackney Division for the needs of each event. Assigned staff will manage taxi service logistics. Level One, North Entrance at 415 Summer Street is the

required location for taxicab drop-off and pick-up. This taxi stand location will be separate from the other transportation operations for the event. MCCA Transportation staff will monitor the volume of taxis, and will request more from the taxicab companies as needed throughout the event.

Rideshare vehicles (such as Uber & Lyft, etc.) are only permitted to pick up and drop off at designated locations. These locations are event-specific, and will appear in the app when you open it to request a vehicle. Signs will be posted throughout the BCEC to direct you to the proper pick-up location.

### **PRIVATE CHARTER SERVICE**

Any exhibitor wishing to pick up or drop off a private charter shuttle on-site must request a staging area from the MCCA Transportation Department. All requests must be made in advance by emailing [MCCATransportationServices@signatureboston.com](mailto:MCCATransportationServices@signatureboston.com). Requests must include the name of the event, the date & time of the trip, name of the bus company, and number of vehicles being used.

Exhibitors may contract directly with the MCCA to provide charter services. Please email [MCCATransportationServices@signatureboston.com](mailto:MCCATransportationServices@signatureboston.com) to request a quote for services.

### **PARKING**

The BCEC currently maintains 1,343 parking spaces in the South Parking Lot. There are also 200 parking spaces that are utilized for valet parking. Please keep in mind that there is no 24-hour parking or overnight parking at the BCEC. In-and-out privileges are only available to those who purchase Exhibitor Parking Passes (only offered for select events, please contact Exhibitor Services with any questions). Any vehicle left at the BCEC overnight is subject to tow at the owner's expense.

For larger events where the amount of parking available on-site is expected to be insufficient to meet the needs of a particular event, the MCCA Transportation Department will work with local parking lots and garages to create an overflow parking plan. Vehicles will be sent off-site, and attendees will be provided with either walking directions back to the BCEC or a shuttle depending on the distance of the parking lot from the BCEC.

Please note that during events where parking is expected to fill the MCCA will restrict parking on-site to single-spaced vehicles only. Exhibitors arriving with box trucks or vehicles with trailers in tow will be directed to park off-site, and will not be permitted into the South lot until the conclusion of the event.

### **PARKING ON LOADING DOCK**

Exhibitor staff members parking on the loading dock and displaying their loading dock parking pass on the dashboard of the motor vehicle for the purpose of unloading cargo have a limit of 20 minutes in order to do so. Exhibitor staff remaining in the loading dock area beyond the 20-minute limit, and/or who do not properly display a valid loading dock parking pass, subject themselves to towing at the vehicle owner/operator's risk and expense.

### **ADA PARKING**

There is an ADA area in the South Parking Lot, in the rear of the facility. Parking is available in these spaces for the same rate as standard self-parking. From there, there is a handicap-accessible sidewalk to Level Zero, where there is an entrance to the BCEC through the Southeast lobby.

# Levy Restaurants BCEC Authorization Request

## *Sample Food and/or Beverage Distribution*

Please complete this form to receive authorization to distribute food or beverages not purchased through Levy Restaurants. Levy Restaurants has exclusive food and beverage distribution rights within the Boston Convention & Exhibition Center (BCEC) and has the responsibility to the City of Boston to strictly regulate any food and beverage activity within the BCEC. Due to strict regulations, any vendor sampling product within the above mentioned parameters must submit a sampling form to Levy Restaurants for approval.

**The Selling of Food and/or Beverage products by any other entity is strictly prohibited.**

Sponsoring Organizations of expositions and trade shows, and/or their exhibitors, may distribute SAMPLE SIZE food and/or beverage products ONLY upon written authorization and adherence to ALL of the conditions outlined below.

### **GENERAL CONDITIONS - FOOD INDUSTRY RELATED SHOWS**

1. Items dispensed are limited to products Manufactured, Processed or Distributed by exhibiting companies.
2. All items are limited to SAMPLE SIZE and must be dispensed/distributed in accordance to Local and State Health Codes:
  - a. Non-Alcoholic Beverages limited to maximum of 4 oz. Sample Size, served in biodegradable (or plastic) cups. No cans or bottles will be permitted.
  - b. Alcoholic beverage sampling is permitted only if you are the manufacturer or distributor of the beverage. Alcoholic beverages must be "sample" sizes (2 oz. for beer/wine, .25 oz for liquor) and can only be served by a licensed Levy Restaurants bartender.
  - c. Food items are limited to "bite size", not to exceed 2 oz. portions or a 2 oz. prepackaged samples.
  - d. All food/beverage items brought in are required by the Boston Health Department to have a temporary Health Permit. This includes prepackaged food samples, samples not intended for consumption on the show floor, and bottled water.
3. Vendors are responsible for all booth rental fees, electrical, plumbing, drayage and all other Levy Restaurants and/or BCEC services.

### **IF YOU DO NOT MEET THE CONDITIONS LISTED ABOVE, THE FOLLOWING POLICIES APPLY:**

**TAKE-AWAY ITEMS AND BUY-OUT FEES.** Any Food and Beverage brought on premises without the written authorization from Levy Restaurants, the BCEC and [NAME Show] Management is strictly prohibited.

1. Take-away items will be assessed and approved on a case by case basis by Levy Restaurants. Take-away items are items that are distributed to attendees but are not intended for immediate consumption at the time of receipt. Requests for take-away items must be submitted no later than DATE.
2. Requests for all Food or Beverage Products brought on the premises for consumption at hosted banquet/booth events or that do not fall within the Sampling parameters listed above may incur a Buy-out Fee by Levy Restaurants. An appropriate buy-out fee will be determined by Levy Restaurants on a case by case basis; however, the buy-out fee will be based on a percentage of the retail pricing for the food and/or beverage item and is subject to all applicable taxes and service charges.

**UNUSED FOOD OR BEVERAGE PRODUCT** that requires pick-up or shipment after the show/event is the responsibility of the Company that is sampling the product. Absolutely NO REFUNDS of Buy-out Fees will be given for Food or Beverage Product if not consumed during show/event.

**FOOD AND BEVERAGE RELATED SERVICES** including storage, delivery, or any other service required for Food and/or Beverage products brought from the outside are not the responsibility of and will NOT be provided by Levy Restaurants.

If these services are required the following charges will be assessed:

1. \$150.00 for a small visi cooler, per day
2. \$300.00 for a large double visi cooler, per day
3. \$25.00 per drop off and per pick-up for steward
4. \$150.00 per day minimum for dry or refrigerated storage, per pallet
5. \$6.00 per 5 pound bag of ice

*Both the refrigerator and cooler require stewarding labor to drop off and retrieve the equipment. A security deposit of \$250 per piece of equipment will also apply.*

**SHIPPING/RECEIVING** Please note that only product you expect to be prepared by, stored by and delivered by Levy Restaurants should be shipped to Levy Restaurants. Please see the Shipping Label, fill it out and ensure it is used properly to ensure proper receiving of your product. You must contact Levy Restaurants prior to shipping items – items not expected will not be received. For all Food and Beverage not purchased through Levy Restaurants, all standard fees mentioned above will be charged where applicable, including 20% Administrative Fee and Applicable Sales Tax.

The Company named below acknowledges they have sole responsibility for the use, servicing or other disposition of such items in compliance with all applicable laws. Accordingly, the firm agrees to indemnify and forever hold harmless Levy Restaurants and the BCEC from all liabilities, damages, losses, costs or expenses resulting directly or indirectly from their use, serving or other disposition of such items.

**Exhibiting firm must provide Levy Restaurants with a Certificate of Insurance showing evidence of Commercial General Liability with an each occurrence limit of \$1,000,000 and naming Levy Premium Foodservice Limited Partnership and Massachusetts Convention Center Authority as additional insured. Information must be received no later than close of business (5:00 PM EST) on \_\_\_\_\_**

Event or Show:		Event or show date(s):		
Exhibiting firm:		Booth no. (s):		
Billing address:	City:	State:	Zip:	Country:
Phone:		Email:		
Ordered by/title:		Show site contact:		
Date:		Contact phone:		

**PLEASE SPECIFY: ITEM / DISTRIBUTION PURPOSE / QUANTITY / PORTION SIZE / METHOD OF DISPENSING**

Before returning this document, please sign the “Agreed” indicating you have read and you agree with all conditions.

Agreed \_\_\_\_\_ Approved \_\_\_\_\_ Date \_\_\_\_\_  
Exhibiting Firm Levy Restaurants

**PLEASE RETURN FORM TO LEVY RESTAURANTS BY \_\_\_\_\_ TO ENSURE CONFIRMATION AND APPROVAL.**

For additional services and information, please contact: Levy Restaurants | Exhibitor Catering Sales Department  
 415 Summer Street | Boston MA 02210 | Tel. 617.954.2382 | Fax 617.954.2159

## **SECTION IX**

### **FREEMAN GENERAL INFORMATION**

**SERVICE INFORMATION**

**BOOTH EQUIPMENT**

Each 10' x 10' booth will be set with 8' black backwall, 3' high black side dividers. Booths 300 sqft or less will receive a one-line identification sign. Booths larger than 300 sqft may receive a one-line identification sign upon request.

**EXHIBIT HALL CARPET**

The exhibit area is *NOT* carpeted; however the aisles will be carpeted in tuxedo. It is mandatory to have carpeting or other suitable floor covering in your booth. Exhibitors may supply their own floor covering or rent carpeting from Freeman. Please see the Freeman Carpet Order Form for carpet types and color options, along with pricing information.

**DISCOUNT PRICE DEADLINE DATE**

Order early on [FreemanOnline](#) to take advantage of advance order discount rates, place your order by [Friday, September 27, 2019](#).

**SHOW SCHEDULE**

**EXHIBITOR MOVE-IN**

For more information and helpful hints on pre-show procedures and move-in, please go to [Pre-Show FAQ](#)

Friday	October 18, 2019	8:00 a.m. - 5:00 p.m.
Saturday	October 19, 2019	8:00 a.m. - 5:00 p.m.
Sunday	October 20, 2019	8:00 a.m. - 2:00 p.m.

**All labor and inbound material handling services performed after 4:30 p.m. on Friday and all day Saturday will have overtime charges applied. All inbound material handling services performed on Sunday will have overtime charges applied. All labor performed on Sunday will have double time charges applied.**

**EXHIBIT HOURS**

Sunday	October 20, 2019	6:00 p.m. - 7:30 p.m.
Monday	October 21, 2019	8:30 a.m. - 5:00 p.m.
Tuesday	October 22, 2019	8:30 a.m. - 5:30 p.m.

**EXHIBITOR MOVE-OUT**

For more information and helpful hints on post-show procedures and move-out, please go to [Post-Show FAQ](#)

Tuesday	October 22, 2019	5:30 p.m. - 11:59 p.m.
Wednesday	October 23, 2019	8:00 a.m. - 5:00 p.m.

**All labor and outbound material handling services performed after 4:30 p.m. will have overtime charges applied.**

**DISMANTLE AND MOVE-OUT INFORMATION**

- Freeman will begin returning empty containers as soon as the aisle carpeting is removed from the exhibit floor.
- All exhibitor materials must be removed from the exhibit facility by [5:00 p.m. on Wednesday, October 23, 2019](#).
- To ensure all exhibitor materials are removed from the exhibit facility by the Exhibitor Move-Out deadline please have all carriers check-in by [3:00 p.m. on Wednesday, October 23, 2019](#).

**POST SHOW PAPERWORK AND LABELS**

Our Exhibitor Services Department will gladly prepare your outbound Material Handling Agreement and labels in advance. Complete the Outbound Shipping form and your paperwork will be available at show site. Be sure your carrier knows the company name and booth number when making arrangements for shipping your exhibit at the close of the show.

**EXCESSIVE TRASH AND BOOTH ABANDONMENT**

Any excessive trash which consists of display materials, carpet, padding, crates and/or pallets will be disposed of and charged both a handling fee and disposal fee during exhibitor move-in. Excessive booth materials and/or literature left in the booth at the end of the published exhibitor move-out that is not labeled for an outbound shipment will be considered abandoned and deemed as trash. The exhibitor will be charged for the removal and disposal of these items. Charges may include Installation & Dismantle Labor, Forklift/Rigging Labor, and/or Dumpster Fee. Please call our Exhibitor Services Department at (508) 894-5100 for a quote.

**SERVICE CONTRACTOR CONTACTS/INFORMATION:**

**FREEMAN**  
 275 Bodwell Street  
 Avon, MA 02322  
 (508) 894-5100 • Fax: (469) 621-5608

**FREEMAN EXHIBIT TRANSPORTATION**  
 (800) 995-3579 US & Canada or +1 (512) 982-4187 Outside the US or +1 (817) 607-5183  
 International Shipping Services or fax (469) 621-5810 or email [exhibit.transportation@freeman.com](mailto:exhibit.transportation@freeman.com)

**FREEMAN ONLINE®**  
 Take advantage of discount pricing by ordering online at [FreemanOnline](#) by **Friday, September 27, 2019**. Using the enhanced FreemanOnline, you will enjoy easy access to added features and functions as well as the high caliber of Freeman services you've come to expect — **before, during** and **after** your show.

To place online orders, you will be required to enter your unique Username and Password. If this is your first time to use FreemanOnline, click on the "Create an Account" link. To access FreemanOnline without using the email link, visit [FreemanOnline](#).

If you need assistance with FreemanOnline, please call our Customer Support Center at (888) 508-5054 Toll Free US and Canada or +1(512) 982-4186 Local and International.

**SHIPPING INFORMATION**

**Warehouse Shipping Address:**  
 Exhibiting Company Name / Booth #  
**AFP 2019**  
 C/O Freeman  
 25 Doherty Ave  
 Avon, MA 02322

**PLEASE NOTE: The warehouse is open from 8:00 a.m. - 4:00 p.m. Monday - Friday. Exceptions are noted below.**

Freeman will accept crated, boxed or skidded material beginning Friday, September 20, 2019 at the above address. Material arriving after Friday, October 11, 2019 will be received at the warehouse with an additional after deadline charge. Please note that the Freeman Warehouse does not accept uncrated freight (loose, pad-wrapped material and/or unskidded machinery), COD shipments, hazardous materials, freight requiring refrigerated or frozen storage, a single piece of freight weighing more than 5,000 pounds or a single piece of freight beyond the dimensions of 108" H x 93" W. Warehouse materials are accepted at the warehouse Monday through Friday between the hours of 8:00 a.m. - 4:00 p.m. Certified weight tickets must accompany all shipments. If required, provide your carrier with this phone number: (508) 894-5100.

**Please Note: The warehouse will be closed on Monday, October 14, 2019 in observance of Columbus Day. Shipments will not be accepted on this date.**

**Show Site Shipping Address:**  
 Exhibiting Company Name / Booth #  
**AFP 2019**  
 C/O Freeman  
 Boston Convention & Exhibition Center  
 415 Summer St.  
 Cypher Street Entrance  
 Boston, Ma 02210

Freeman will receive shipments at the exhibit facility beginning at 8:00 a.m. Friday, October 18, 2019. Shipments arriving before this date may be refused by the facility. Any charges incurred for early freight accepted by the facility will be the responsibility of the exhibitor. Certified weight tickets must accompany all shipments. If required, provide your carrier with this phone number: (508) 894-5100.

**Please Note:** Any materials received by Freeman are subject to Material Handling Charges and are the responsibility of the Exhibitor. This also applies to items not ordered through the Official Show Vendors. Refer to the material handling form for charges for the service.

Please be aware that disposal of exhibit properties is not included as part of your material handling charges. Please contact Freeman for your quoted rates and rules applicable to disposal of your exhibit properties.

#### LABOR INFORMATION

Union Labor may be required for your exhibit installation and dismantle. Please carefully read the UNION RULES AND REGULATIONS to determine your needs. Exhibitors supervising Freeman labor will need to pick up and release their labor at the Labor Desk. Refer to the order form under Display Labor for Straight time and Overtime hours.

#### ASSISTANCE

We want you to have a successful show. If we can be of assistance, please call our Exhibitor Services Department at (508) 894-5100.

WE APPRECIATE YOUR BUSINESS!

## FREEMAN GENERAL INFORMATION

### TRANSLATION SERVICE

Freeman is pleased to offer a new service for our international exhibitors that provides quick interpretation and translation in 150 languages. This service will not only interpret for us on a three-way conversation, but also translate emails from customers. To access this service you may contact Freeman Boston Exhibitor Services at (508) 894-5100 or Freeman's Customer Support Center at (888) 508-5054 US & Canada or +1 (512) 982-4186 Local & International.

### HELPFUL HINTS

#### SAVE MONEY

Order early on [FreemanOnline](#) to take advantage of advance order discount rates, place your order by Friday, September 27, 2019.

#### AVOID DELAY

Ship early to avoid delays. Shipments arriving late at show site will cost you money, time and business!

#### SAFETY TIPS

Use a ladder, not a chair. Standing on chairs, tables and other rental furniture is unsafe and can cause injury to you or to others. These objects are not designed to support your standing weight.

Be aware of your surroundings. You are in an active work area with changing conditions during move-in and move-out. Pay attention. Look for obstacles, and machinery and equipment that are in use.

Keep your eyes open for scooters and forklifts. The drivers of these vehicles may not be able to see you.

Stay clear of dock areas, trucks and trailers. These areas can be particularly dangerous.

Prevent electrical shocks, falling items and damage to materials. Do not attach items or equipment to the drapes or metal framework provided for your booth. This can cause serious injury or damage to materials.

We discourage children from being in the exhibit hall during installation and dismantle. If children are present during installation and dismantle, they must be supervised by an adult at all times.

Freeman does not ship or handle Hazardous Materials. If any materials you are shipping to the event fall into this category, please contact Freeman to be sure that the material will be allowed at the facility and by the association. In addition, if authorized by the facility and the association, you will need to make separate arrangements for the transport and handling of the approved materials, since Freeman will not transport or handle them.

The operation or use of all motorized lifts and motorized material handling equipment for installation/dismantle of exhibits is NOT permitted by exhibitors or by their exhibitor appointed contractors (EAC's). Thank you for your cooperation.

#### EXHIBITOR ASSISTANCE

For more information and helpful hints on pre-show procedures and move-in, please go to [Pre-Show FAQ](#)

For more information and helpful hints on post-show procedures and move-out, please go to [Post-Show FAQ](#)

Call Freeman's Exhibitor Services department at (508) 894-5100 with any questions or needs you may have.

## Interested in going green and saving money?

Follow these tips to make sure your sustainable booth strategies are cost-neutral or even cost-saving! Leave an impact on the show floor, not the environment.



# 1 BEFORE THE SHOW

## booth structure

### Option 1 Multiple Use

Use **Forest Sustainable Certified (FSC)** wood to build your booth and crates.

Get creative! Design your booth with a **small shipping footprint** to minimize carbon emissions. Freeman's eye-catching stretch-fabric booth designs pack up small (and light!) for shipping.

### Option 2 One-time Use

Rent locally from nearby Freeman offices to reduce both shipping costs and carbon emissions.

# 2 carpet

### Option 1 Rent

Rent rather than buy carpet to save on shipping, cleaning, and storage. Freeman Classic carpet can be reused at least four times.

### Option 2 Color

Use darker-colored carpet, which is easier to reuse and recycle. Freeman Classic dark-colored carpets are made of 20-50 percent recycled content.



# 3 shipping



**Online + before deadline = better bottom line.** Take advantage of early-bird pricing and consolidate shipping when ordering supplies.



**Choose reusable shipping padding.** Avoid packing peanuts and foam plastic materials that never decompose.



**Ship early.** Use the 30-day policy to ship materials to the Freeman advance warehouse.

# 4 graphics

### Option 1 Multiple Use

Print on a durable substrate **without dates, event names, or locations.**

### Option 2 One-time Use

Print on 100 percent recyclable materials like Freeman Honeycomb and Smartbuild Eco, which are just as cost-effective as PVC.

# 5 printing



Reduce printing and **go digital** with your booth literature.



**Print locally.** Supporting local businesses while reducing shipping? It's a win-win.



Print on at least **50 percent post-consumer recycled paper.**

# 6

## ON SITE

### save energy



**Use Energy Star-rated equipment** for audio-visual equipment and monitors.



**Power down.** Turn off equipment at the end of each day.



**Light up your booth** with CFLs, LEDs, or other energy-efficient lighting.

# 8

### shipping out

**Pack in, pack out.**

Leave no traces on show site.

**Join a caravan.**

If you're shipping directly to another show, ask **Freeman Transportation** about **joining a caravan** to your next show.

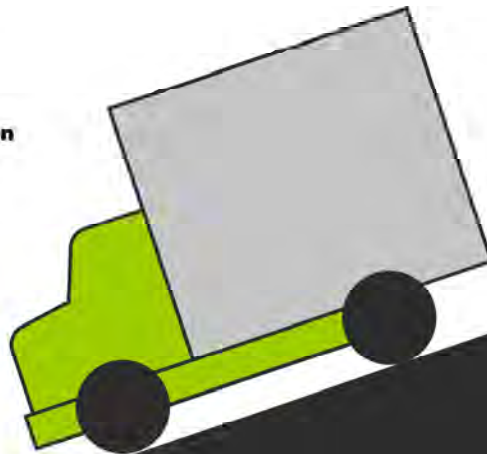

# 7

## MOVE OUT

### train your team

Educate your installation and dismantling teams about **recycling and donation processes.**



# 9

### leftover materials

**Remember to label.**

Clearly **label recyclable leftover material** for disposal.

**Donate the rest.**

Ask the Freeman Exhibitors Services desk about local donation programs.

**TYPICALLY\*  
DONATE-ABLE**

**Furniture:** Purchased items  
Home furnishings: Décor staging materials

**Unused raw materials:** Plywood, subflooring, non-laminate wood

**Flooring:** 100 square feet of flooring. Excludes carpet.

**Left over giveaways:** Pens, pads of paper, sunglasses, USBs, etc., left over in your promotional giveaway

**TYPICALLY\*  
RECYCLABLE**

**Cardboard:** Used for signs or shipping boxes

**Glass:** Green, brown, clear

**Plastics:** Shrink-wrap or plastic banding used to secure shipments; water/soda bottles; plexiglass (acrylics) clear, smoked, or tinted; Visqueen used to protect flooring

**Metal:** Aluminum cans/ steel banding

**Paper:** Fliers, brochures, programs, tickets, office paper, newspaper, magazines, paperboard

**Wood:** Non-laminate wood

## **SECTION X**

### **FREEMAN PAYMENT INFORMATION**

# FREEMAN

275 Bodwell Street  
Avon, MA 02322  
(508) 894-5100 • Fax: (469) 621-5608



DISCOUNT PRICE  
DEADLINE DATE  
SEPTEMBER 27, 2019

INCLUDE THIS FORM  
WITH YOUR ORDER  
PLEASE USE BLACK INK

NAME OF SHOW: **AFP 2019 / OCTOBER 20-23, 2019**

COMPANY NAME: \_\_\_\_\_ BOOTH #: \_\_\_\_\_

ADDRESS: \_\_\_\_\_ BOOTH SIZE: X

CITY/STATE/ZIP: \_\_\_\_\_

PHONE #: \_\_\_\_\_ EXT.: \_\_\_\_\_ FAX #: \_\_\_\_\_

SIGNATURE: \_\_\_\_\_ PRINT NAME: \_\_\_\_\_

CONTACT'S E-MAIL: \_\_\_\_\_

E-MAIL FOR INVOICE: \_\_\_\_\_  CHECK IF YOU ARE A NEW FREEMAN CUSTOMER

**Invoices will be sent by e-mail; please provide the e-mail address of the person who reconciles your invoices if different than contact's email.**

## METHOD OF PAYMENT

BY SUBMITTING THIS FORM OR ORDERING MATERIALS OR SERVICES FROM FREEMAN, YOU AGREE TO BE BOUND BY ALL TERMS & CONDITIONS INCLUDED IN YOUR SERVICE MANUAL.

COMPANY CHECK  
Please make check payable to: Freeman. Checks must be in U.S. funds drawn on a U.S. or Canadian bank. ("US. FUNDS" MUST BE PRE-PRINTED on Canadian checks.)  
**Please reference (482532) on your remittance.**

BANK TRANSFER  
Bank Transfer to Bank of America, N.A.; Dallas, TX  
*Wire Transfer*  
ABA#: 026009593 ACCT #1252039192 Freeman  
*International Wire Transfer*  
Swift Code: BOFAUS3N ACCT #1252039192 Freeman  
*ACH Direct Deposit*  
ABA# 111000012 ACCT #1252039192 Freeman

CREDIT/DEBIT CARD  
For your convenience, we will use this authorization to charge your credit/debit card account for your advance orders, and any additional amounts incurred as a result of show site orders placed by your representative. These charges may include all Freeman companies, or any charges which Freeman may be obligated to pay on behalf of Exhibitor, including without limitation, any shipping charges. Please complete the information requested below:

**Bank Address for Wire and ACH is 901 Main St, Dallas, TX 75202**  
**Please reference Name of Show & Booth Number so we can properly credit your account.**

**Note: Customers are responsible for any bank processing fees.**

AMERICAN EXPRESS  MASTERCARD  VISA **We do not accept credit card information via email.**

ACCOUNT NO.: \_\_\_\_\_ EXP. DATE: \_\_\_\_\_

CARDHOLDER NAME (PRINT): \_\_\_\_\_ SIGNATURE: \_\_\_\_\_

CARDHOLDER BILLING ADDRESS: \_\_\_\_\_

CITY/STATE/ZIP: \_\_\_\_\_

## ENTER TOTALS HERE

FURNISHINGS & ACCESSORIES	CARPET	RENTAL EXHIBITS & ACCESSORIES	INSTALLATION LABOR	DISMANTLE LABOR	ELECTRICAL LABOR	CLEANING SERVICES
MATERIAL HANDLING	RIGGING INSTALLATION	RIGGING DISMANTLE	SIGNS	TOTALFLEX	EXHIBIT TRANSPORTATION	GRAND TOTAL

- Remember to order in advance to save time and money. You may place your order by phone, fax, mail, or use our online ordering service at: [www.freeman.com](http://www.freeman.com).
- Orders received without payment or after the discount price deadline date will be charged at the standard price.
- Copies of invoices may be picked up from the Freeman Service Center prior to show closing.
- If you have questions or need assistance with any items not listed, please call and ask for Exhibitor Sales.

FREEMAN method of payment

# FREEMAN

275 Bodwell St  
Avon, MA 02322  
(508) 894-5100 Fax: (469) 621-5608



## AFP 2019 / OCTOBER 20-23, 2019

**In order to authorize Freeman to invoice a third party for payment of services rendered to exhibitors, both the exhibiting company and the third party must complete this form and return it at least 14 days prior to show move-in.**

### EXHIBITING COMPANY AUTHORIZATION OF THIRD PARTY BILLING

"We understand and agree that we, the exhibiting company, are ultimately responsible for payment of charges and agree by submitting this form or ordering materials or services from Freeman, to be bound by all terms and conditions as described in the Terms & Conditions section of this service manual. In the event that the named third party does not discharge payment of the invoice prior to the last day of the show, charges will revert back to the exhibiting company. All invoices are due and payable upon receipt, by either party. The items checked below are to be invoiced to the third party."

BY SUBMITTING THIS FORM VIA FAX OR POSTAL MAIL OR ORDERING MATERIALS OR SERVICES FROM FREEMAN, YOU AGREE TO BE BOUND BY ALL TERMS & CONDITIONS INCLUDED IN YOUR SERVICE MANUAL.

EXHIBITOR NAME: (PLEASE PRINT) \_\_\_\_\_

EXHIBITOR SIGNATURE: \_\_\_\_\_

DATE: \_\_\_\_\_

### EXHIBITING COMPANY INFORMATION

EXHIBITING COMPANY NAME: \_\_\_\_\_

BOOTH #: \_\_\_\_\_

EXHIBITING COMPANY ADDRESS: \_\_\_\_\_

CITY/STATE/ZIP: \_\_\_\_\_

PHONE: \_\_\_\_\_

EXT. \_\_\_\_\_

FAX: \_\_\_\_\_

CONTACT'S E-MAIL: \_\_\_\_\_

### Indicate which services are to be invoiced to the Third Party:

- |   |   |
|---|---|
| <input type="checkbox"/> ALL FREEMAN SERVICES       | <input type="checkbox"/> FREEMAN EXHIBIT TRANSPORTATION |
| <input type="checkbox"/> I&D LABOR/SUPERVISION      | <input type="checkbox"/> RENTAL FURNITURE/CARPET/SIGNS  |
| <input type="checkbox"/> MATERIAL HANDLING/IN & OUT | <input type="checkbox"/> BOOTH CLEANING                 |
|   | <input type="checkbox"/> OTHER _____                    |

**FOR ACCURACY PURPOSES, COPIES OF ALL INVOICES WILL BE SENT TO THE EXHIBITOR OF RECORD AT THE CONCLUSION OF THE SHOW.**

### THIRD PARTY COMPANY INFORMATION

THIRD PARTY COMPANY NAME: \_\_\_\_\_

CONTACT NAME: \_\_\_\_\_

THIRD PARTY BILLING ADDRESS: \_\_\_\_\_

CITY/STATE/ZIP: \_\_\_\_\_

PHONE: \_\_\_\_\_

EXT: \_\_\_\_\_

FAX: \_\_\_\_\_

CONTACT'S E-MAIL: \_\_\_\_\_

E-MAIL FOR INVOICE: \_\_\_\_\_

Invoices will be sent by e-mail; please provide the e-mail address of the person who reconciles your invoices if different than contact's e-mail.

### THIRD PARTY CREDIT/DEBIT CARD AUTHORIZATION

- AMERICAN EXPRESS    MASTERCARD    VISA   **We do not accept credit card information via email.**

ACCOUNT NO: \_\_\_\_\_

EXP. DATE: \_\_\_\_\_

CARDHOLDER NAME (PLEASE PRINT): \_\_\_\_\_

CARD TYPE: \_\_\_\_\_

AUTHORIZED SIGNATURE: \_\_\_\_\_

CARDHOLDER BILLING ADDRESS: \_\_\_\_\_

CITY/STATE/ZIP: \_\_\_\_\_

# PAYMENT & LABOR

## YOU ARE ENTERING A CONTRACT WHICH LIMITS YOUR POSSIBLE RECOVERY IN CASE OF LOSS OR DAMAGE.

The terms and conditions set forth below become a part of the Contract between FREEMAN and you, the EXHIBITOR. Acceptance of said terms and conditions will be construed when any of the following conditions are met:

- THE METHOD OF PAYMENT FORM IS SIGNED; OR
- AN ORDER FOR LABOR, SERVICES AND/OR RENTAL EQUIPMENT IS PLACED BY EXHIBITOR WITH FREEMAN; OR
- WORK IS PERFORMED ON BEHALF OF EXHIBITOR BY LABOR SECURED THROUGH FREEMAN.

## DEFINITIONS

For purposes of this Contract, "FREEMAN" or "The Freeman Companies" means Freeman Expositions, Inc., Freeman Expositions, Ltd., Freeman Audio Visual, Inc., Exhibit Surveys, Inc., Freeman Exhibit, Freeman Transportation, FreemanXP, Inc., Stage Rigging, Inc., The Freeman Company, Freeman Electrical, Inc., Freeman Digital Ventures, Inc., and their respective employees, directors, officers, agents, assigns, affiliated companies, and related entities including, but not limited to, any subcontractors FREEMAN may appoint. The term "EXHIBITOR" means the Exhibitor, its employees, agents, representatives, and any Exhibitor Appointed Contractors ("EAC").

## PAYMENT TERMS

Full payment, including any applicable tax, is due in advance or at show site. All payments must be in U.S. secure funds and all checks must be drawn on a U.S. bank. Orders received without advance payment or after the deadline date will incur additional charges as indicated on each order form. Payment for Audio Visual services and equipment is due in advance of move-in, unless otherwise agreed in writing with Freeman. All materials and equipment are on a rental basis for the duration of the show or event and remain the property of FREEMAN except where specifically identified as a sale. All rentals (excluding Audio Visual equipment and computers) include delivery, installation, and removal from EXHIBITOR'S booth. Rental prices on Audio Visual equipment and computers do not include labor, delivery, electrical services or removal of the equipment from the booth. In case of cancellation of any orders or services by EXHIBITOR, a one-hour "per person, per hour" charge will be applied for all labor orders that are not canceled in writing at least 24 hours prior to the scheduled start time. If Prestige Carpet, Custom-Cut Carpet, Modular Rental Exhibits and any other custom-order items or services have already been provided at the time of cancellation, fees will remain at 100% of the original charge. Audio Visual orders cancelled within 7 days from the show opening date will be charged a one-day rental rate on equipment. On-site cancellation of Audio Visual services will result in a one-day rental charge of equipment and any applicable labor. If the Show or Event is canceled because of reasons beyond FREEMAN'S control, EXHIBITOR remains responsible for all charges for services and equipment provided up to and including the date of cancellation. FREEMAN will not issue refunds to EXHIBITOR of any payments made before the date of cancellation. It is EXHIBITOR'S responsibility to advise the FREEMAN Service Center Representative of problems with any orders, and to check the EXHIBITOR'S invoice for accuracy prior to the close of the Show or Event. If EXHIBITOR is exempt from payment of sales tax, FREEMAN requires an exemption certificate for the State in which the services are to be used. Resale certificates are not valid unless EXHIBITOR is rebilling these charges to its customers. For International EXHIBITORS, FREEMAN requires 100% prepayment of advance orders, and any order or services placed at show site must be paid at the show. For all others, should there be any pre-approved unpaid balance after the close of the show; terms will be net, due and payable in DALLAS, TEXAS upon receipt of invoice. Effective 30 days after invoice date, any unpaid balance will bear a FINANCE CHARGE at the lesser of the maximum rate allowed by applicable law, or 1.5% per month, which is an ANNUAL PERCENTAGE RATE of 18%, and future orders will be on a prepaid basis only. If any finance charge hereunder exceeds the maximum rate allowed by applicable law, the finance charge shall automatically be reduced to the maximum rate allowed, and any excess finance charge received by FREEMAN shall be either applied to reduce the principal unpaid balance or refunded to the payer. If past due invoices or invoice balances are placed with a collection agency or attorney for collection or suit, EXHIBITOR agrees to pay all legal and collection costs. THESE PAYMENT TERMS AND CONDITIONS SHALL BE GOVERNED BY AND CONSTRUED IN ACCORDANCE WITH THE LAWS OF THE STATE OF TEXAS. In the event of any dispute between the EXHIBITOR and FREEMAN relative to any loss, damage, or claim, such EXHIBITOR shall not be entitled to and shall not withhold payment, or any partial payment, due to FREEMAN for its services, as an offset against the amount of any alleged loss or damage. Any claims against FREEMAN shall be considered a separate transaction, and shall be resolved on its own merits. FREEMAN reserves the right to charge EXHIBITOR for the difference between the EXHIBITOR'S estimate of charges and the actual charges incurred by EXHIBITOR, or for any charges that FREEMAN may be obligated to pay on behalf of EXHIBITOR, including without limitation, any shipping charges. If EXHIBITOR provides a credit card for payment and charges are rejected by the EXHIBITOR'S credit card company for any reason, FREEMAN hereby provides notice that it reserves the right, and EXHIBITOR authorizes FREEMAN, to continue to attempt to secure payment through that credit card for as long as unpaid balances remain on the EXHIBITOR'S account. In the event that a THIRD PARTY orders on behalf of the EXHIBITOR and the named THIRD PARTY does not discharge payment of the invoice prior to the last day of the show, charges will revert back to the EXHIBITOR. All invoices are due and payable upon receipt, by either party.

## ELECTRICAL

If FREEMAN provides electrical services, claims will not be considered, or adjustments made unless filed in writing, by EXHIBITOR, prior to the close of the event. FREEMAN is not responsible for any damage or loss caused by the loss of power beyond its control and EXHIBITOR agrees to hold FREEMAN, its officers, directors, employees and agents harmless from such power loss. IN NO EVENT SHALL FREEMAN BE LIABLE FOR ANY INDIRECT OR CONSEQUENTIAL DAMAGES (INCLUDING WITHOUT LIMITATION LOST PROFITS) EVEN IF ADVISED OF THE POSSIBILITY OF SUCH DAMAGES, WHETHER UNDER THEORY OF CONTRACT, TORT (INCLUDING NEGLIGENCE), PRODUCTS LIABILITY OR OTHERWISE. EXHIBITOR shall indemnify and hold harmless FREEMAN, its officers, directors, employees, and agents from and against any and all claims, liabilities, damages, fines, penalties or costs of whatsoever nature (including reasonable attorneys' fees) arising out of or in any way connected with EXHIBITOR'S actions or omissions under this Agreement. Please note that electrical services are NOT automatically included in Audio Visual rentals and must be ordered separately from the designated electrical provider.

## LABOR UNDER THE SUPERVISION OF EXHIBITOR RESPONSIBILITIES

EXHIBITOR shall be responsible for the performance of labor provided under this option. It is the responsibility of EXHIBITOR to supervise labor secured through FREEMAN in a reasonable manner as to prevent bodily injury and/or property damage and also to direct them to work in a manner that is in compliance with FREEMAN'S Safe Work Rules and/or Federal, State, County and Local ordinances, rules and/or regulations, including but not limited to Show or Facility Management rules and/or regulations. If any labor secured through Freeman is conducting overhead work, the Exhibitor is responsible for ensuring that everyone in the area of overhead work is wearing a hard hat. If the Exhibitor does not have its own hard hats, Freeman can assist with obtaining them. It is the responsibility of EXHIBITOR to check in with the Service Desk to pick up labor, and to return to the Service Desk to release labor when the work is completed.

## INDEMNIFICATION

EXHIBITOR agrees to indemnify, hold harmless, and defend FREEMAN from and against any and all demands, claims, causes of action, fines, penalties, damages, liabilities, judgments, and expenses (including but not limited to reasonable attorneys' fees and investigation costs) for bodily injury, including any injury to FREEMAN employees, and/or property damage arising out of work performed by labor provided by FREEMAN but supervised by EXHIBITOR. Further, the EXHIBITOR'S indemnification of FREEMAN includes any and all violations of Federal, State, County or Local ordinances, "Show Regulations and/or Rules" as published and/or set forth by Facility or Show Management, and/or directing labor provided by FREEMAN to work in a manner that violates any of the above rules, regulations, and/or ordinances.

## IMPORTANT

PLEASE REFER TO FREEMAN'S "MATERIAL HANDLING TERMS & CONDITIONS" AS IT RELATES TO MATERIAL HANDLING SERVICES AND TO THE "SERVICE REQUEST & SHIPPING INSTRUCTIONS CONTRACT" AS IT RELATES TO TRANSPORTATION SERVICES. CONTRACT TERMS DEPEND ON THE NATURE OF SERVICES SECURED BY EXHIBITOR THROUGH FREEMAN. TERMS & CONDITIONS MAY VARY FOR EACH TYPE OF SERVICE ORDERED THROUGH FREEMAN.

# MATERIAL HANDLING

**YOU ARE ENTERING A BINDING CONTRACT WHICH LIMITS YOUR POSSIBLE RECOVERY IN CASE OF LOSS OR DAMAGE.** Acceptance of said terms and conditions will be construed when any of the following conditions are met: This Material Handling Agreement (MHA) is signed; Exhibitor's materials are delivered to Freeman's warehouse or to an event site for which Freeman is the Official Show Contractor; or an order for labor and/or rental equipment is placed by Exhibitor with Freeman. Please be aware that disposal of exhibit properties is not included as part of your material handling charges. Please contact freeman for your quoted rates and rules applicable to disposal of your exhibit properties.

**1. DEFINITIONS.** For purposes of this Contract, Freeman means Freeman Expositions, Inc., and its employees, directors, officers, agents, assigns, affiliated companies, and related entities. In no event shall Freeman be deemed to be the Ultimate Consignee for shipping and custom purposes. The term "Exhibitor" means the Exhibitor, its employees, agents, and representatives.

**2. PACKAGING/CRATES AND STORAGE.** Freeman shall not be responsible for damage to loose or uncrated materials, pad wrapped or shrink-wrapped materials, glass breakage, concealed damage, carpets in bags or poly, or improperly packed or labeled materials. Freeman shall not be responsible for crates and packaging which are unsuitable for handling, in poor condition, or have prior damage. Crates and packaging should be of a design to adequately protect contents for handling by forklift and similar means. Freeman does not accept any crates or packaging containing hazardous materials. Goods requiring cold storage and those in accessible storage are stored at Exhibitor's own risk. **FREEMAN ASSUMES NO RESPONSIBILITY OR LIABILITY FOR LOSS OR DAMAGE TO GOODS IN COLD STORAGE OR ACCESSIBLE STORAGE.**

**3. EMPTY CONTAINERS.** Empty container labels will be available at the show site service desk. Affixing labels to the containers is the sole responsibility of Exhibitor or its representative. All previous labels must be removed or obliterated. Freeman assumes no responsibility for: error in the above procedures; removal of containers with old empty labels and without Freeman labels; or improper information on empty labels. **FREEMAN WILL NOT BE LIABLE FOR LOSS OR DAMAGE TO CRATES AND CONTAINERS OR THEIR CONTENTS WHILE SAME ARE IN EMPTY CONTAINER STORAGE.**

**4. INBOUND/OUTBOUND SHIPMENTS.** There may be a lapse of time between the delivery of shipment(s) to the booth and the arrival of Exhibitor, or a lapse of time between the completion of packing and the actual pickup of materials from the booths for loading onto a carrier and during such times, Exhibitor materials will be left unattended. **FREEMAN IS NOT RESPONSIBLE OR LIABLE FOR ANY LOSS, DAMAGE, THEFT, OR DISAPPEARANCE OF EXHIBITOR'S MATERIALS AFTER THEY HAVE BEEN DELIVERED TO EXHIBITOR'S BOOTH AT SHOW SITE OR BEFORE THEY HAVE BEEN PICKED UP FOR RELOADING AT THE CONCLUSION OF THE EVENT.** Freeman recommends the securing of security services from Facility or Show Management. All MHA's submitted to Freeman by Exhibitor will be checked at the time of pickup from the booth and corrections will be made where discrepancies exist between the quantities of items on any form submitted to Freeman and the actual count of such items in the booth at the time of pickup. Freeman is not responsible for any wait time or other charges including business center charges arising from delivery or pickup of Exhibitor's materials.

**5. DELIVERY TO THE CARRIER FOR RELOADING.** Freeman assumes no responsibility for loss, damage, theft, or disappearance of Exhibitor's materials after same have been delivered to Exhibitor's appointed carrier, shipper, or agent for transportation after the conclusion of the show. Freeman loads the materials onto the carrier under directions from the carrier or driver of that carrier. Any loading onto the carrier will be understood to be under the exclusive supervision and control of the carrier or driver of that carrier. **FREEMAN ASSUMES NO RESPONSIBILITY FOR LOSS, DAMAGE, THEFT OR DISAPPEARANCE OF EXHIBITOR'S MATERIALS THAT ARISES OUT OF IMPROPERLY LOADED OR LABELED MATERIALS.**

**6. DESIGNATED CARRIERS.** Freeman shall have the authority to change the Exhibitor designated carrier if that carrier does not pick up the shipment(s) at the appointed time. Where no disposition is made by Exhibitor, materials may be taken to a warehouse to await Exhibitor's shipping instructions and Exhibitor agrees to be responsible for charges relating to such rerouting and handling. **IN NO EVENT SHALL FREEMAN BE RESPONSIBLE FOR ANY LOSS RESULTING FROM SUCH REROUTING DESIGNATION.**

**7. FORCE MAJEURE.** Freeman's performance hereunder is subject to, and Freeman shall not be responsible for loss, delay, or damage due to, strike, work stoppages, natural elements, vandalism, Act of God, civil disturbances, power failures, explosions, acts of terrorism or war, or for any other cause beyond Freeman's reasonable control, nor for ordinary wear and tear in the handling of Exhibitor's materials.

**8. CLAIM(S) FOR LOSS.** Exhibitor agrees that any and all claims for loss or damage must be submitted to Freeman immediately at the show site and in any case not later than **thirty (30) business days** after the date when Exhibitor's materials are delivered to the carrier for transportation from show site or from Freeman's warehouse. All claims reported after thirty (30) days will be rejected. In no event shall a suit or action be brought against Freeman **more than one (1) year** after the date of loss or damage occurred.

**a. PAYMENT FOR SERVICES MAY NOT BE WITHHELD.** In the event of any dispute between the Exhibitor and Freeman relative to any loss, damage, or claim, Exhibitor shall not be entitled to and shall not withhold payment due Freeman for its services as an offset against the amount of any alleged loss or damage. Any claims against Freeman shall be considered a separate transaction and shall be resolved on their own merits.

**b. MAXIMUM RECOVERY.** If found liable for any loss, Freeman's sole and exclusive maximum liability for loss or damage to Exhibitors materials and Exhibitor's sole and exclusive remedy is limited to \$50 (USD) per pound per article with a maximum liability of \$100.00 (USD) per item, or \$1,500.00 (USD) per shipment whichever is less. All shipment weights are subject to correction and final charges determined by the actual or re-weighted weight of the shipment.

**c. LIMITATION OF LIABILITY.** IN NO EVENT SHALL FREEMAN BE LIABLE TO THE EXHIBITOR OR TO ANY OTHER PARTY FOR SPECIAL, COLLATERAL, EXEMPLARY, INDIRECT, INCIDENTAL, OR CONSEQUENTIAL DAMAGES, WHETHER SUCH DAMAGES OCCUR EITHER PRIOR OR SUBSEQUENT TO, OR ARE ALLEGED AS A RESULT OF, TORTIOUS CONDUCT, FAILURE OF THE EQUIPMENT OR SERVICES OF FREEMAN OR BREACH OF ANY OF THE PROVISIONS OF THIS CONTRACT, REGARDLESS OF THE FORM OF ACTION, WHETHER IN CONTRACT OR IN TORT, INCLUDING STRICT LIABILITY AND NEGLIGENCE, EVEN IF FREEMAN HAS BEEN ADVISED OR HAS NOTICE OF THE POSSIBILITY OF SUCH DAMAGES. SUCH EXCLUDED DAMAGES INCLUDE BUT ARE NOT LIMITED TO LOST PROFITS, LOSS OF USE, AND INTERRUPTION OF BUSINESS OR OTHER CONSEQUENTIAL OR INDIRECT ECONOMIC LOSSES.

**9. DECLARED VALUE.** Declarations of Declared Value are between the Exhibitor and the selected Carrier ONLY, and are in no way an extension of Freeman's maximum liability stated herein. Freeman will use commercially reasonable efforts to transmit the Declared Value instructions to the selected Carrier; however, **FREEMAN WILL NOT BE LIABLE FOR ANY CLAIM ARISING FROM THE TRANSMITTAL OF, OR FAILURE TO TRANSMIT, DECLARED VALUE INSTRUCTIONS TO THE CARRIER NOR FOR FAILURE OF THE CARRIER TO UPHOLD THE DECLARED VALUE OR ANY OTHER TERM OF CARRIAGE.**

**10. JURISDICTION / VENUE.** THIS CONTRACT SHALL BE CONSTRUED UNDER THE LAWS OF THE STATE OF TEXAS WITHOUT GIVING EFFECT TO ITS CONFLICT OF LAWS RULES. EXCLUSIVE VENUE FOR ALL DISPUTES ARISING OUT OF OR RELATING TO THIS CONTRACT SHALL RESIDE IN A COURT OF COMPETENT JURISDICITON IN DALLAS COUNTY, TEXAS.

**11. INDEMNIFICATION.** Exhibitor agrees to indemnify and forever hold harmless Freeman from and against any and all demands, claims, causes of action, fines, penalties, damages (including consequential), liabilities, judgments, and expenses (including but not limited to reasonable attorneys' fees and investigation costs) arising out or contributed to by Exhibitor's negligent supervision of any labor secured through Freeman; Exhibitor's negligence, willful misconduct, or deliberate act, or the negligence, willful misconduct, or deliberate act of Exhibitor's employees, agents, representatives, customers, invitees and/or any Exhibitor Appointed Contractors (EAC) at the show or event to which this Contract relates, including but not limited to Exhibitor's violation of Federal, State, County or Local ordinance and/or Exhibitor's violation of Show Regulations and/or Rules as published and set forth by Facility and/or Show Management.

**12. LIEN.** Exhibitor grants Freeman a security interest in and a lien on all of Exhibitor's materials that is from time to time in the possession of Freeman and all the proceeds thereof, including without limitation insurance proceeds (the "Collateral"), to secure the prompt and full payment and performance of all Exhibitor's indebtedness for monies paid, by Freeman on its behalf, services performed, materials and/or labor from time to time provided by Freeman to or for the benefit of Exhibitor ("Obligations"). Freeman shall have all the rights and remedies of a secured party under the Uniform Commercial Code, as may be amended from time to time ("UCC"), and any notice that Freeman is required to give under the UCC of a time and place of a public sale or the time after which any private sale or other intended disposition of any Collateral is to be made shall be deemed to constitute reasonable notice if such notice is mailed by registered or certified mail at least five (5) days prior to such action. Freeman may hold and not deliver any of the Collateral to Exhibitor for so long as there are any Obligations that remain unpaid or unsatisfied.

**13. WAIVER & RELEASE.** Exhibitor, as a material part of the consideration to Freeman for material handling services, waives and releases all claims against Freeman with respect to all matters for which Freeman has disclaimed liability pursuant to the provisions of this Contract.

**14. DRIVER LIABILITY WAIVER.** IN CONSIDERATION OF FREEMAN PERMITTING ENTRANCE TO THE PREMISES, YOU, YOUR EMPLOYER, THE OWNER OF THE TRUCK AND/OR EQUIPMENT THAT YOU ARE OPERATING (TRUCKOWNER) AND YOU AS AGENT OF YOUR EMPLOYER AND THE TRUCKOWNER, HEREBY ASSUME ALL RISK OF INJURY OR HARM TO YOURSELF AND OTHERS AND DAMAGE TO YOUR PROPERTY AND PROPERTY BELONGING TO YOUR EMPLOYER OR OTHERS ARISING FROM YOUR ACTIVITIES WHILE BEING PERMITTED TO ENTER THE PREMISES. YOU AGREE TO ENTER AT YOUR OWN RISK. YOU HAVE FULL KNOWLEDGE OF ANY RISK INVOLVED IN THIS ACTIVITY. YOU RECOGNIZE THE HAZARDS AND ARE AWARE OF ALL THE RULES FOR SAFE OPERATION. YOUR EMPLOYER, THE TRUCKOWNER, AND YOU AGREE TO INDEMNIFY AND HOLD HARMLESS FREEMAN, ITS EMPLOYEES, OFFICERS, DIRECTORS, AGENTS, ASSIGNS, AFFILIATED COMPANIES AND RELATED ENTITIES, AGAINST ANY AND ALL LIABILITY, ACTIONS, CLAIMS, AND DAMAGES OF ANY KIND WHATSOEVER ARISING FROM YOUR ACTIVITIES WHILE BEING PERMITTED TO ENTER THE PREMISE.

# AIR CARGO

## AIR CARGO SERVICE REQUEST AND SHIPPING INSTRUCTIONS CONTRACT

In tendering this shipment, the Shipper and Consignee agree to these TERMS which no agent or employee of the parties may alter. This Air Service Request and Shipping Instruction Contract is NON-NEGOTIABLE and has been prepared by Shipper, or if by Freeman or another on Shipper's behalf, it shall be deemed, conclusively, to have been prepared by the Shipper. The Shipper agrees that this shipment is subject to the TERMS stated herein All TERMS, including but not limited to, all the limitations of liability, shall apply to our agents and their contracting carriers.

**1. DEFINITIONS:** In this Contract, "Freeman" means Freeman Decorating Services, Inc., and its respective employees, officers, directors, agents, assigns, affiliated companies, and related entities including any contractors appointed by Freeman. The term "Shipper" means the person or business for whom the property is being transported, and includes their respective employees, officers, directors, agents, assigns, affiliated companies, and contractors appointed by the Shipper, excluding only Freeman. "Property" is all objects of any type received from the Shipper for transport by Freeman as described herein. "Consignee" is the party to whom Shipper has designated the goods are to be delivered.

**2. FINAL CONTRACT BETWEEN THE PARTIES:** In exchange for Shipper's payments and Freeman's services, which the parties have specified in this two-page Contract (including the Air Cargo Service Request and Shipping Instructions), Freeman and Shipper each agree that this Contract shall govern their respective rights and obligations regarding transportation of Shipper's property. This Contract shall take effect when the property first comes into the physical possession of Freeman, and the responsibility of Freeman under same shall end when the property has been placed in the possession of the Consignee or the Consignee's designated agent. If any part or provision of this Contract is found by a court of competent jurisdiction to be void or unenforceable, the remainder of the Contract shall continue in full force and effect.

**3. Freeman's RESPONSIBILITIES UNDER THE CONTRACT ARE LIMITED:** Freeman is responsible for the satisfactory performance of only those services which it directly provides under this Contract. Freeman shall not be responsible for the performance of individuals of firms who are not under the direct supervision or control of Freeman. Freeman shall not be responsible for events or causes of loss, delay, or damage beyond its reasonable control, including (by way of illustration only, and not as a limitation on the breadth of this clause), strike, lockout, work slowdown or stoppage, power failure, breakdown of plant or machinery, facility failure, vandalism, theft, Act of God, effect of natural elements, riot, civil commotion or disturbance, terrorism, act of war or belligerent parties, and any other cause or causes beyond the reasonable control of Freeman. EXCEPT FOR ELIGIBLE GUARANTEED SERVICE SHIPMENTS, Freeman DOES NOT GUARANTEE DELIVERY BY ANY SPECIFIC TIME OR DATE.

**4. PACKAGING AND CRATES:** Shipper's property must be well packaged for safe and secure handling, storage and shipment using ordinary care. Each piece must be legibly and durably marked with the name and address, including correct ZIP code of the Shipper and Consignee. When a container is used repeatedly by Shipper, Shipper must remove all old labels, tags, markings, etc., and Shipper must ensure that the container retains adequate strength for transportation. Freeman makes neither representation nor any warranty regarding the acceptability or suitability of any packaging system or procedure that Shipper might use for its property. Freeman shall not be responsible for damage to loose or uncrated materials, padded or shrink-wrapped materials, glass breakage, concealed damage, carpets in bags or poly, or improperly packed or labeled materials. Crates and packaging should be of a design to adequately protect contents for handling by forklift and similar means. General guidance as to acceptable packaging systems and procedures may be found in publications such as the National Motor Freight Classification, published by the National Motor Freight Traffic Association. For shipments of Perishable Commodities, U.S. and Canadian shipments must be packed to travel without spoilage for 72 hours from time of pickup; all International shipments must be packed to travel without spoilage for 24 hours beyond an agreed deadline. Freeman reserves the right to periodically embargo regions of the world due to conditions that may cause damage to perishable commodities. If the integrity of a shipment is in question, Freeman reserves the right to improve packaging at shipper's expense.

**5. REFUSED SHIPMENTS:** If the Consignee refuses a shipment tendered for delivery or if Freeman is unable to deliver a shipment because of fault or mistake of the Consignor or Consignee, Freeman's liability shall then become that of a warehouseman.

- Freeman shall promptly attempt to provide notice, by telephonic, electronic or written communication as provided on the face of these shipping instructions, if so indicated, to Shipper or the party, if any, designated to receive notice in these instructions.
- Storage charges, based on Freeman's applicable rates, shall start no sooner than the next business day following the attempted notification. Storage may be, at Freeman's option, in any location that provides reasonable protection against loss or damage. Freeman may place the shipment in public storage at the owner's expense and without liability to Freeman.
- If Freeman does not receive disposition instructions within 48 hours of the time of Freeman's attempted first notification, Freeman will attempt to issue a second and final confirmed notification. Such notice shall advise that if Freeman does not receive disposition instructions within 10 days of that notification, Freeman may offer the shipment for sale at a public auction and Freeman has the right to offer the shipment for sale. The amount of sale will be applied to Freeman's invoice for transportation, storage and other lawful charges. Shipper will be responsible for the balance of charges not covered by the sale of the goods. If there is a balance remaining after all charges and expenses are paid, such balance will be paid to the owner of the property sold hereunder, upon claim and proof of ownership.
- Where Freeman has attempted to follow the procedure set forth above and the procedure is not possible, nothing shall be construed to abridge the right of Freeman, at its option, to sell the property under such circumstances and in such manner as may be authorized by law.
- When perishable goods cannot be delivered and disposition is not given within a reasonable time, Freeman may dispose of property to the best advantage. Where Freeman is directed by Consignee or Consignor to unload or deliver property at a particular location where Consignor, Consignee, or the Agent of either is not regularly located, Freeman's liability for the shipment shall terminate after unloading or delivery.

**6. LIMITATION ON SHIPPER'S RECOVERABLE DAMAGES:** FREEMAN'S LIABILITY FOR DAMAGES ON DOMESTIC SHIPMENTS, INCLUDING BUT NOT LIMITED TO THOSE DAMAGES ARISING FROM OR RELATED TO MISDELIVERY, INCOMPLETE OR OTHERWISE INADEQUATE DELIVERY (INCLUDING BUT NOT LIMITED TO FAILURE TO FOLLOW SHIPPER OR CONSIGNEE INSTRUCTIONS OR FAILURE TO COLLECT OR PROPERLY DELIVER A PAYMENT INSTRUMENT), NONDELIVERY, MISSED PICKUP, AND LOSS OF OR DAMAGE TO CARGO, SHALL BE LIMITED TO THE HIGHER OF \$50.00 (USD) PER SHIPMENT OR \$.50 (USD) PER POUND (\$1.10 (USD) PER KILOGRAM) OF CARGO ADVERSELY AFFECTED THEREBY, PLUS TRANSPORTATION CHARGES APPLICABLE TO THAT PART OF THE SHIPMENT ADVERSELY AFFECTED THEREBY, UNLESS AT TIME OF SHIPMENT THE SHIPPER MAKES A DECLARATION OF VALUE FOR CARRIAGE IN THE SPACE DESIGNATED ON THE SERVICE REQUEST AND SHIPPING INSTRUCTIONS FORM AND PAYS THE APPROPRIATE VALUATION CHARGE. IN NO EVENT SHALL FREEMAN'S LIABILITY EXCEED THE DECLARED VALUE OF THE SHIPMENT OR THE AMOUNT OF LOSS OR DAMAGE ACTUALLY SUSTAINED, WHICHEVER IS LOWER. IF CARRIAGE OF THE SHIPMENT IS SOLELY OR PARTLY BY AIR AND INVOLVES AN ULTIMATE DESTINATION OR A STOP IN A COUNTRY OTHER THAN THE COUNTRY OF DEPARTURE, Freeman's LIABILITY FOR CARGO LOST, DAMAGED OR DELAYED SHALL BE LIMITED TO \$9.07 PER POUND (\$20.00 PER KILOGRAM) FOR CARRIAGE SUBJECT TO THE UNAMENDED WARSAW CONVENTION OR THE WARSAW CONVENTION AS AMENDED BY THE HAGUE PROTOCOL OF 1955, 17 SPECIAL DRAWING RIGHTS PER KILOGRAM FOR CARRIAGE SUBJECT TO THE WARSAW CONVENTION AS AMENDED BY THE MONTREAL PROTOCOL NO. 4 OF 1975, OR \$9.07 PER POUND (\$20.00 PER KILOGRAM) FOR CARRIAGE WHERE THE WARSAW CONVENTION, INCLUDING ITS AMENDMENTS, DOES NOT APPLY FOR ANY REASON, UNLESS A HIGHER DECLARED VALUE IS REQUESTED, AND THE FEES SET FORTH IN THE SERVICE GUIDE FOR SUCH HIGHER DECLARED VALUE ARE PAID. FOR INTERNATIONAL SHIPMENTS, THIS SHIPPING REQUEST AND SHIPPING INSTRUCTION CONTRACT SHALL BE DEEMED AN AIR WAYBILL WITHIN THE MEANING OF THE WARSAW CONVENTION.

Notwithstanding the above limitations, domestic shipments containing the following items of extraordinary value are limited to a maximum declared value of \$500.00 (USD):

- artworks and objects of art, including without limitation original paintings, drawings, etchings, water colors, tapestries and sculpture;
  - clocks, watches, jewelry (including costume jewelry), furs and fur-trimmed clothing;
  - personal effects;
  - and other inherently fragile or unique items, including prototypes, etc.
- Any declared value in excess of the maximums allowed herein is null and void, and the acceptance by Freeman for carriage of any shipment with a declared value in excess of the allowed maximums does not constitute a waiver of these maximums. Shipper understands that even if Shipper is not able to participate or fully participate in a show due to loss of, theft of, or damage to its property, Freeman shall never be liable or responsible for damages identified by the terms (by way of example only and not in limitation of the breadth of this clause) such as the following: consequential damages, loss of use damages, loss of profits damages, business interruption damages, delay damages, special damages, collateral damages, exemplary damages, damages awarded for gross negligence, direct damages, indirect damages, damages for failure of performance, breach of contract damages, fraud damages, or any other sort of damage for tort or breach of contract. This limitation shall bind the parties:
- whenever or wherever the claimed loss or damage may occur;
  - even though the alleged loss or damage is claimed to result from negligence, strict liability, products liability, breach of contract, breach of statute or regulation, or any other legal theory or cause, and;
  - even though Freeman may have been advised or be on notice of the possibility or even the probability of such damages. Freeman makes no warranties, express or implied, and expressly disclaims any and all warranties. Except for Freeman's failure to deliver in accordance with the Guaranteed Service section of the Service Guide, Freeman will not be liable for misdelivery, incomplete or otherwise inadequate delivery (including but not limited to failure to follow Shipper or Consignee instructions or failure to collect or properly deliver a payment instrument), non-delivery, missed pickup, delay on International shipments, loss or damage unless caused by Freeman's sole negligence.

### 7. SHIPPER'S RESPONSIBILITIES AND INDEMNIFICATION:

- Shipper must pay in full for the services rendered under this Contract at the time the services are requested. The existence of a dispute between Shipper and Freeman relative to any claim or other matter shall have no bearing on this duty of payment. No claim submitted by or on behalf of Shipper will be processed unless Shipper's account is current.
- Shipper understands and acknowledges that Freeman does not accept or transport illegal, dangerous or hazardous materials of any kind or nature. Shipper warrants and ensures that its property is inert, and contains no Hazardous Substances, Hazardous Materials, Chemicals, Gases, Explosives, Radioactive Materials, Biologically hazardous agents, or any other substance, matter or object in any form that could pose a threat to the health or safety of persons, property or the public welfare in general. Such goods may be warehoused at owner's risk and expense or destroyed without compensation.
- Shipper shall defend and indemnify Freeman, its employees, directors, officers, and agents from and against any and all demands, claims, causes of action, fines, penalties, damages (including consequential), liabilities, judgments, and expenses (including but not limited to reasonable attorneys' fees and investigation costs) on account of personal injury, death, or damage to or loss of property or profits arising out of or contributed to by any of the following: Shipper's negligence, willful misconduct, or deliberate act; Shipper's violation of Federal, State, County or Local ordinances; Shipper's violation of Show Regulations and/or Rules as published and set forth by Facility and/or Show Management; and/or Shipper's failure to comply with (b) of this Agreement regarding the inclusion of any dangerous substances in the property placed with Freeman.

**8. CLAIMS:** Shipper, Consignee, or any other party claiming an interest in the shipment must notify Freeman immediately upon delivery, or in the case of loss or damage which could not have been noted at the time of delivery, within five (5) business days of delivery, of any loss or damage to the shipment. Notice of concealed damage must be confirmed in writing or via email at [exhibit.transportation@freeman.com](mailto:exhibit.transportation@freeman.com) within 5 business days of receipt of the property. If Carrier schedules an inspection, claimant must hold the shipping container, all packaging material and contents in the same condition as they were in when damage was discovered. Receipt of the shipment by the Consignee or the Consignee's agent without written notice on the delivery receipt and/or delivery manifest will be prima facie evidence that the shipment was delivered in good condition. The amount of the claim may not be deducted from the transportation charges. Notice of loss or damage MUST be reported to Freeman at 800-995-3579. The shipment, its container(s), and packing material must be made available to Freeman for inspection at the delivery location. All shipments are subject to opening for inspection by Freeman; however, Freeman is not obligated to perform such inspection. All claims for loss or damage MUST be made in writing to Freeman within one hundred and twenty (120) calendar days after the date of acceptance of the shipment by Freeman. Please refer to the Service Guide for claim procedures. All claims for service failure must be made within thirty (30) calendar days from the date of shipment and Freeman's sole liability for such claims arising from Guaranteed Service shipments shall be limited to the transportation charges as provided in the Guaranteed Service section of the Service Guide. All claims for overcharge must be made in writing to Freeman within sixty (60) calendar days after the invoice date. No claim for loss or damage may be maintained against Freeman unless (a) claimant complies with all requirements of this section and (b) for domestic shipments, if the claimant commences the action within one (1) year of the shipment by Freeman unless otherwise required by International, Federal or State Law. If the claim is for loss or damage involving International shipments, claimant must commence the action within two (2) years from the date of acceptance of the shipment by Freeman unless otherwise required by International, Federal or State Law. For purposes of this section, no action shall be deemed to have commenced until receipt by Freeman of service of process of the action on Freeman. Claims for loss or damage must be delivered to the following address: Sedgwick, PO Box 14151, Lexington, KY 40512-4151.

For shipping containers designed for repeated use (tradeshow cases, totes, crates), Freeman shall have no liability for superficial damage to said containers in the form of scuffs, scratches, dents or dings. Freeman will only accept liability for "catastrophic" damage to these shipping containers (crushing, puncture, or complete destruction). Freeman's maximum liability in cases of "catastrophic" damage or total loss will be limited to a depreciated value of the container based on the time elapsed from the original purchase and the purchase price established on the provided original invoice. This maximum liability will be subject to all other applicable limits of liability such as repair costs.

**9. CHOICE OF FORUM:** THIS CONTRACT SHALL BE CONSTRUED UNDER THE LAWS OF THE UNITED STATES (INCLUDING ADOPTED INTERNATIONAL CONVENTIONS) AND THE STATE OF TEXAS WITHOUT GIVING EFFECT TO THE STATE'S CONFLICT OF LAWS RULES. FREEMAN AND SHIPPER AGREE THAT ANY CLAIM OR DISPUTE OF ANY SORT ARISING OUT OF OR IN ANY WAY RELATED TO THIS CONTRACT, ITS PERFORMANCE OR NONPERFORMANCE, OR DAMAGES ALLEGEDLY RESULTING FROM SAME WILL BE ARBITRATED IN THE CITY OF DALLAS, TEXAS, AND THE RULES OF THE AMERICAN ARBITRATION ASSOCIATION WILL APPLY. IF BINDING ARBITRATION IS UNAVAILABLE TO RESOLVE ANY CONTROVERSY AND IT IS NECESSARY TO LITIGATE THE DISPUTE, THE DISPUTE SHALL BE LITIGATED IN A COURT OF COMPETENT JURISDICTION IN DALLAS COUNTY, TEXAS.

**10. MISCELLANEOUS:** Shipper warrants the accuracy of the weight and dimension data furnished in this Contract. Shipper understands that once its property is shipped by Freeman pursuant to the instructions contained in this Contract, Shipper has no right to control the shipment; stop the shipment in transit, or divert or reschedule same, and that Shipper will have no control over the property until it is delivered pursuant to the instructions in this Contract. Shipper agrees that this Contract may be provided to any third party, including common or contract carriers of cargo by air, water, rail, or road, for the purpose of confirming the right of Freeman to control the handling of the property and all matters related to payment for the shipment.

# MOTOR CARGO

## MOTOR CARGO SERVICE REQUEST AND SHIPPING INSTRUCTIONS CONTRACT

This Contract establishes your legal obligations with regard to the property described herein being shipped with Freeman Transportation. It specifically limits your rights and possible recovery if your property is lost or damaged. You must accept all terms and conditions of this Contract. You confirm that you have read and agree with all the terms and conditions of this Contract by receipt without contest. This Contract may not be waived or varied, except in writing, and then only by an authorized representative of Freeman.

**1. DEFINITIONS.** In this Contract, "Freeman" means Freeman Expositions, Inc., and its respective employees, officers, directors, agents, assigns, affiliated companies, and related entities including any contractors appointed by Freeman. The term "Shipper" means the person or business for whom the property is being transported, and includes their respective employees, officers, directors, agents, assigns, affiliated companies, and contractors appointed by the Shipper, excluding only Freeman. "Property" is all objects of any type received from the Shipper for transport by Freeman as described herein. "Consignee" is the party to whom Shipper has designated the goods are to be delivered.

**2. FINAL CONTRACT BETWEEN THE PARTIES.** In exchange for Shipper's payments and Freeman's services, which the parties have specified in this Contract, Freeman and Shipper each agree that this Contract shall govern their respective rights and obligations regarding transportation of Shipper's property. This Contract shall take effect when the property first comes into the physical possession of Freeman for inbound shipments and after loading on the applicable carrier for outbound shipments, and the responsibility of Freeman under same shall end when the property has been placed in the possession of the Consignee or the Consignee's designated agent. If any part or provision of this Contract is found by a court of competent jurisdiction to be void or unenforceable, the remainder of the Contract shall continue in full force and effect.

**3. FREEMAN'S RESPONSIBILITIES UNDER THE CONTRACT ARE LIMITED.** Freeman shall not be responsible for the performance of individuals or firms who are not under the direct supervision or control of Freeman. Freeman shall not be responsible for events or causes of loss, delay, or damage beyond its reasonable control, including (by way of illustration only, and not as a limitation on the breadth of this clause), strike, lockout, work slowdown or stoppage, power failure, breakdown of plant or machinery, facility failure, vandalism, theft, Act of God, effect of natural elements, riot, civil commotion or disturbance, terrorism, act of war or belligerent parties, and any other cause or causes beyond the reasonable control of Freeman. Freeman shall not be liable for delay caused by highway obstructions, or faulty or impassable highways, or lack of capacity of any highway, bridge, or ferry, or caused by breakdown or mechanical defects of vehicles or equipment, or from any cause other than the negligence of Freeman. Freeman shall not be bound to transport by any particular schedule, means, vehicle or otherwise, other than with reasonable dispatch.

**4. PACKAGING AND CRATES.** Shipper's property must be well packaged for safe and secure handling, storage and shipment using ordinary care. Freeman makes neither representation nor any warranty regarding the acceptability or suitability of any packaging system or procedure that Shipper might use for its property. Freeman shall not be responsible for damage to loose or uncrated materials, padwrapped or shrink-wrapped materials, glass breakage, concealed damage, carpets in bags or poly, or improperly packed or labeled materials. Crates and packaging should be of a design to adequately protect contents for handling by forklift and similar means. General guidance as to acceptable packaging systems and procedures may be found in publications such as the National Motor Freight Classification, published by the National Motor Freight Traffic Association. If the integrity of a shipment is in question, Freeman reserves the right to improve packaging at shipper's expense.

**5. PERISHABLE GOODS.** Goods of a perishable nature are carried in dry trailers without environmental or atmospheric control or other special services unless Shipper states on the face of the "Service Request and Shipping Instructions" that the goods are to be carried in a refrigerated, heated, specially ventilated or otherwise specially equipped trailer. This carriage may be subject to additional charges. Shipper is responsible for bringing the goods to the proper temperature before loading the goods into the trailer, for the proper stowage of the goods within the trailer, and for setting the temperature (including maintenance and repair), during all times after the trailer is spotted by Freeman and before the trailer is received by Freeman. Freeman is not responsible for product deterioration caused by inherent vice, defects in the merchandise or transit times in excess of product shelf life. Refrigerated, heated, specially ventilated or otherwise specially equipped trailers are not equipped to change the temperature of goods (they are equipped only to maintain temperature). Shipper will give written notice of requested temperature setting of the thermostatic controls before receipt of the goods by Freeman. When a loaded trailer is received, Freeman will verify that the thermostatic controls are set to maintain trailer temperature as requested. Freeman is unable to determine whether the goods were at the proper temperature when they were loaded into the trailer or when the trailer is delivered to Freeman. Air temperature at the unit sensor will be maintained within a proper range of plus or minus 5 degrees Fahrenheit of the temperature requested by Shipper on the face of the "Service Request and Shipping Instructions" if the goods were at that temperature when loaded into the container and if the temperature controls were properly set when the container was loaded.

**6. REFUSED SHIPMENTS.** If the Consignee refuses a shipment tendered for delivery or if Freeman is unable to deliver a shipment because of fault or mistake of Freeman, Freeman's liability shall then become that of a warehouseman.

(a) Freeman shall promptly attempt to provide notice, by telephonic, electronic or written communication as provided on the face of these shipping instructions, if so indicated, to Shipper or the party, if any, designated in these instructions to receive notice.

(b) Storage charges, if applicable, shall start no sooner than the next business day following the attempted notification. Storage may be, at Freeman's option, in any location that provides reasonable protection against loss or damage. Freeman may place the shipment in public storage at the owner's expense and without liability to Freeman.

(c) If Freeman does not receive disposition instructions within 48 hours of the time of Freeman's attempted first notification, Freeman will attempt to issue a second and final confirmed notification. Such notice shall advise that if Freeman does not receive disposition instructions within 10 days of that notification, Freeman may offer the shipment for sale at a public auction and Freeman has the right to offer the shipment for sale. The amount of sale will be applied to Freeman's invoice for transportation, storage and other lawful charges. Shipper will be responsible for the balance of charges not covered by the sale of the goods. If there is a balance remaining after all charges and expenses are paid, such balance will be paid to the owner of the property sold hereunder, upon claim and proof of ownership.

(d) Where Freeman has attempted to follow the procedure set forth above and the procedure is not possible, nothing shall be construed to abridge the right of Freeman, at its option, to sell the property under such circumstances and in such manner as may be authorized by law.

(e) When perishable goods cannot be delivered and disposition is not given within a reasonable time, Freeman may dispose of property to the best advantage. When Freeman is directed by Consignee or Consignor to unload or deliver property at a particular location where Consignor, Consignee, or the Agent of either is not regularly located, Freeman's liability for the shipment shall terminate after unloading or delivery.

**7. INSURANCE. Freeman IS NOT AN INSURER.** Shipper is responsible for obtaining insurance for its property. Freeman provides no insurance for Shipper or its property.

**8. LIMITATION ON SHIPPER'S RECOVERABLE DAMAGES.** Shipper understands that even if shipper's property is lost, stolen, or damaged, Freeman does not pay replacement or restoration cost of any property. **FREEMAN'S MAXIMUM LIABILITY SHALL BE THE AMOUNT OF PROVEN ACTUAL VALUE NOT EXCEEDING THE LOWER OF FAIR MARKET VALUE.**

**(THE "FAIR MARKET VALUE" EQUALS THE AS IS WHERE IS PRICE FOR THE PROPERTY AT THE LOCATION OF THE SHOW TO WHICH PRICE A WILLING BUYER AND A WILLING SELLER WOULD AGREE IN AN ORDINARY COURSE OF BUSINESS, ARM'S LENGTH SALE.) OR \$5.00 (USD) PER POUND OF CARGO LOST OR DAMAGED UNLESS AT THE TIME OF SHIPMENT SHIPPER MAKES A DECLARATION OF VALUE FOR CARRIAGE IN THE SPACE DESIGNATED ON THE SHIPPING INSTRUCTIONS AND PAYS THE APPROPRIATE VALUATION CHARGE.** Even if Shipper has made a declaration of value, liability shall never exceed the depreciated original invoice value or the fair market value of the property, whichever is less. The value per pound for applying declared valuation charges shall be determined by dividing Shipper's declared value for carriage by the actual weight of the shipment. In all cases not prohibited by law, where a lower value than the actual value of the said property has been stated in writing by Shipper or has been agreed upon in writing as the released value of the property upon which the rate is based, such lower value plus freight charges, if paid, shall be the maximum recoverable amount for loss or damage. **Notwithstanding the above limitations, all shipments containing the following items of extraordinary value are limited to a maximum declared value of \$500.00 (USD):** (a) Artworks and objects of art, including without limitation, original paintings, drawings, etchings, watercolors, tapestries and sculptures or prototypes; (b) Clocks, jewelry, including costume jewelry, furs, and fur-trimmed clothing; (c) Personal effects, including without limitation, papers and documents; or (d) Coin money, currency, gift certificates, debit cards, credit cards, and any other items of extraordinary value. (e) For either unmarked, unlabeled, or improperly packaged television monitors, the maximum liability is the lesser of \$3.00 (USD) per pound or the actual invoice price.

Any declared value in excess of the maximums allowed herein is null and void, and the acceptance by Freeman of carriage of any shipment with a declared value in excess of the allowed maximums does not constitute a waiver of these maximums. In any event, (excluding small package program shipments) **Freeman's MAXIMUM LIABILITY WILL NEVER BE MORE THAN \$100,000 PER SHIPMENT.** Shipper understands that even if Shipper is not able to participate or fully participate in a Show due to loss of, theft of, or damage to their property, Freeman shall not be liable or responsible for damages identified by the terms (by way of example only and not in limitation of the breadth of this clause) such as the following: consequential damages, loss of use damages, loss of profits damages, business interruption damages, delay damages, special damages, collateral damages, exemplary damages, damages awarded for gross negligence, direct damages, indirect damages, or damages for failure of performance, breach of contract damages, fraud damages, or any other sort of damage for tort or breach of contract. This limitation shall bind the parties: **(a) WHENEVER OR WHEREVER THE CLAIMED LOSS OR DAMAGE MAY OCCUR; (b) EVEN THOUGH THE ALLEGED LOSS OR DAMAGE IS CLAIMED TO RESULT FROM NEGLIGENCE, STRICT LIABILITY, PRODUCTS LIABILITY, BREACH OF CONTRACT, BREACH OF STATUTE OR REGULATION, OR ANY OTHER LEGAL THEORY OR CAUSE, AND; (c) EVEN THOUGH FREEMAN MAY HAVE BEEN ADVISED OR BE ON NOTICE OF THE POSSIBILITY OR EVEN THE PROBABILITY OF SUCH DAMAGES.**

### 9. SHIPPER'S RESPONSIBILITIES AND INDEMNIFICATION:

(a) Shipper must pay in full for the services rendered under this Agreement at the time the services are requested. The existence of a dispute between Shipper and Freeman relative to any claim or other matter shall have no bearing on this duty of payment. No claim may be submitted by or on behalf of Shipper to Freeman unless Shipper's account is current.

(b) Shipper understands and acknowledges that Freeman does not accept or transport illegal or hazardous materials of any kind or nature. Shipper warrants and will ensure that its property is inert, and contains no Hazardous Substances, Hazardous Materials, Chemicals, Gasses, Explosives, Radioactive Materials, Biologically hazardous agents, or any other substance, matter or object in any form that could pose a threat to the health or safety of Freeman persons, property, or the public welfare in general. Such goods may be warehoused at owner's risk and expense or destroyed without compensation.

(c) Shipper shall defend and indemnify Freeman, its employees, directors, officers, and agents from and against any and all demands, claims, causes of action, fines, penalties, damages (including consequential), liabilities, judgments, and expenses (including but not limited to reasonable attorneys' fees and investigation costs) on account of personal injury, death, or damage to or loss of property or profits arising out of or contributed to by any of the following: Shipper's negligence, willful misconduct, or deliberate act; Shipper's violation of Federal, State, County or Local ordinances; Shipper's violation of Show Regulations and/or Rules as published and set forth by Facility and/or Show Management; and/or Shipper's failure to comply with subsection (b) of this section regarding the inclusion of any dangerous substances in the property placed with Freeman.

**10. CLAIMS.** Claims must be filed in writing within nine (9) months after the date of delivery of the property (or in the case of export traffic, within nine (9) months after delivery at the port of export), except that claims for failure to make delivery must be filed within nine (9) months after a reasonable time for delivery has elapsed. Suits for loss, damage, or delay shall be instituted against Freeman no later than two (2) years and one (1) day from the day when written notice is given by Freeman to the claimant that Freeman has disallowed the claim or any part or parts of the claim specified in the notice. Shipper shall deliver notice of claim for loss or damage by hand, U.S. mail, courier, facsimile, or electronic means to Sedgwick, PO Box 14151, Lexington, KY 40512-4151 as soon as loss or damage is discovered. The notice of claim shall invite a prompt joint survey of the damage, at a time and place to be agreed between the parties, and such survey shall go forward promptly. However, if in any case the property is received by the Consignee or the Consignee's agent without notice of loss or damage to property being served on Freeman within 5 business days of the receipt of the property, it is agreed between Freeman and Shipper that in that instance the presumption shall arise that the property was delivered in proper quantity and in good condition. Notice of concealed damage must be confirmed in writing or via email at [exhibit.transportation@freeman.com](mailto:exhibit.transportation@freeman.com) within 5 business days of receipt of the property. If Carrier schedules an inspection, claimant must hold the shipping container, all packaging material and contents in the same condition as they were in when damage was discovered. Claims filed more than nine (9) months following the date on which the property was delivered or should have been delivered are agreed to be forever time barred.

For shipping containers designed for repeated use (tradeshow cases, totes, crates), Freeman shall have no liability for superficial damage to said containers in the form of scuffs, scratches, dents or dings. Freeman will only accept liability for "catastrophic" damage to these shipping containers (crushing, puncture, or complete destruction). Freeman's maximum liability in cases of "catastrophic" damage or total loss will be limited to a depreciated value of the container based on the time elapsed from the original purchase and the purchase price established on the provided original invoice. This maximum liability will be subject to all other applicable limits of liability such as repair costs.

**11. CHOICE OF FORUM / ARBITRATION.** THIS CONTRACT SHALL BE CONSTRUED UNDER THE LAWS OF THE STATE OF TEXAS WITHOUT GIVING EFFECT TO ITS CONFLICT OF LAWS RULES. EXCLUSIVE VENUE FOR ALL DISPUTES ARISING OUT OF CONTRACT, TORT, COMMON LAW OR RELATING TO THE ENFORCEMENT OR INTERPRETATION OF THIS CONTRACT SHALL RESIDE IN A COURT OF COMPETENT JURISDICTION IN DALLAS COUNTY, TEXAS. Notwithstanding anything herein to the contrary, any controversy or claim arising out of or relating to this Agreement, or the breach thereof, shall be exclusively settled by arbitration administered by the American Arbitration Association in accordance with its Commercial Arbitration Rules and judgment on the award rendered by the arbitrator(s) may be entered by any court having jurisdiction thereof.

**12. MISCELLANEOUS.** (a) Shipper warrants the accuracy of the weight and dimension data furnished in this Contract; (b) Shipper understands that once its property is shipped by Freeman pursuant to the instructions contained in this Contract, Shipper has no right to control the shipment, stop the shipment in transit, or divert or reschedule same. (c) Shipper agrees that this Contract may be provided to any third party, including common or contract carriers of cargo by air, water, rail, or road, for the purpose of confirming the right of Freeman to control the handling of the property and all matters related to payment for the shipment. Shipper agrees that all shipments are subject to correction and final charges determined by the actual or re-weighed weight of the shipment.

**13. SMALL PACKAGE PROGRAM.** If items shipped via Freeman's Small Packages program are lost, damaged or destroyed while in Freeman's possession, **FREEMAN'S MAXIMUM LIABILITY SHALL BE \$100 per package UNLESS AT THE TIME OF SHIPMENT SHIPPER MAKES A DECLARATION OF VALUE IN THE SPACE DESIGNATED ON THE SHIPPING INSTRUCTIONS AND PAYS THE APPROPRIATE VALUATION CHARGE.** If small packages are received by the Shipper and notice of loss or damage is not received by Freeman within 15 days of the delivery of the property, the parties agree that the presumption shall arise that the property was delivered in proper quantity and in good condition.

## **SECTION XI**

### **FREEMAN SERVICES AND ORDER FORMS**

**\*Order By: September 27, 2019 to Receive Early Order Pricing!**

**Company Name:**



Meeting Room Event Technology Packages (Daily Rentals)	QTY.	Early Order	Daily Rate	Total
<b>Small Meeting Room Package (Up to 50 people)</b>				
96" Tripod Screen with Skirt, Projector(4000 Lumens), Projection Stand with Skirt, Sound System, Computer Direct Interface Box, Wireless Microphone, and Microphone Stand		\$650.00	\$845.00	
<b>Medium Meeting Room Package (50 - 150 people)</b>				
7.5' X 10' Fast fold Screen, Projector (4000 Lumens), Projection Stand with Skirt, Sound System, Computer Direct Interface Box, Wireless Microphone, and Microphone Stand		\$1,100.00	\$1,430.00	
<b>Large Meeting Room Package (150 people +)</b>				
10' X 14' Fast fold Screen, Projector (6000 Lumens) , Projection Stand with Skirt, Sound System, Computer Direct Interface Box, Wireless Microphone, and Microphone Stand		\$1,450.00	\$1,885.00	
<b>Meeting Room Flat Screen Packages (Daily Rentals)</b>				
46" Flat Screen Package - 1080P, with Dual Post Stand and External USB Media Player		\$520.00	\$676.00	
55" Flat Screen Package - 1080P, with Dual Post Stand and External USB Media Player		\$725.00	\$942.50	
70" Flat Screen Package - 1080P, with Dual Post Stand and External USB Media Player		\$1,015.00	\$1,319.15	



A La Carte Meeting Room Equipment (Daily Rentals)	QTY.	Early Order	Daily Rate	Total
LCD XGA Computer Projector (4000 Lumens)		\$425.00	\$552.50	
Projection Stand (for LCD and Overhead Projectors)		\$20.00	\$26.00	
Tripod Screen Circle One: 70" \$30 • 84" \$35 • 96" \$45		\$	\$	
Choose: Blu-ray -or- DVD Player		\$75.00	\$97.50	
Small High Performance PA System (2 speakers, 1 Mixer/Amp)		\$165.00	\$214.50	
Wireless Microphone - Choose One: Handheld -or- Headset -or- Lavalier		\$120.00	\$156.00	
Computer Direct Interface Box (Audio)		\$40.00	\$52.00	
Laptop Computer (Core i5/2.5ghz/4GB/300GBHD/DVD)		\$165.00	\$214.50	
HP Laser Printer (40 PPM)		\$97.50	\$126.75	
Wireless Presentation Mouse		\$30.00	\$39.00	
Flip Chart w/ Pad with Markers		\$40.00	\$52.00	



Quoted Additional Equipment	QTY.	Early Order	Daily Rate	Total

**Freeman has a full complement of Computer, Audio, Video and Lighting Inventory, as well as design capabilities. Whether your needs are big or small, our experts are available to help you!**  
**Please contact us at: 214.333.1817 for a custom quote.**

**\*Early order rate is subject to a 30% increase when ordering equipment after September 27, 2019.**



Contact Your Freeman Representative	Total Your Order	
<b>MIMI TON</b> <a href="mailto:mimi.ton@freeman.com">mimi.ton@freeman.com</a> Phone: 214.333.1817 Fax: 469.621.5608 Online at: <a href="http://www.freeman.com">www.freeman.com</a>	Equipment Sub-Total	
	33% Handling Charge (\$212.00 Min) Includes Delivery, Install & Dismantle	
	Added Labor to Mount Client Owned Flat Screen to Stand (\$75)	
	State Rental Tax on Equipment Only (6.25%)	
	<b>TOTAL CHARGES:</b>	
<b>Don't see what you are looking for?</b> <b>Please call to discuss the options!</b>	** Please note for Monitor Stand & Mount Rentals: Additional labor may be required to mount client provided monitors ** Electrical Services are not included in equipment pricing.	



**\*Order By: September 27, 2019 to Receive Early Order Pricing!**



<b>Exhibiting Company Name:</b>	<b>Booth #:</b>
---------------------------------	-----------------

Packages	QTY.	Early Order	Show Rate	Total
Apple iPad with Floor Stand - White		\$295.00	\$383.50	
32" Flat Screen Package - 1080P, with Dual Post Stand and External USB Media Player		\$720.00	\$936.00	
42" Flat Screen Package - 1080P, with Dual Post Stand and External USB Media Player		\$870.00	\$1,131.00	
46" Flat Screen Package - 1080P, with Dual Post Stand and External USB Media Player		\$1,035.00	\$1,345.50	
55" Flat Screen Package - 1080P, with Dual Post Stand and External USB Media Player		\$1,445.00	\$1,878.50	

Flat Screen Monitors	QTY.	Early Order	Show Rate	Total
24" Flat Screen - 1080P, with Dell Sound Bar - Choose One: Table Top -or- Wall Mounted		\$290.00	\$377.00	
32" Flat Screen - 1080P, with Internal Speakers - Choose One: Table Top -or- Wall Mounted		\$475.00	\$617.50	
42" Flat Screen - 1080P, with Internal Speakers - Choose One: Table Top -or- Wall Mounted		\$625.00	\$812.50	
46" Flat Screen - 1080P, with Internal Speakers - Choose One: Table Top -or- Wall Mounted		\$790.00	\$1,027.00	
55" Flat Screen - 1080P, with Internal Speakers - Choose One: Table Top -or- Wall Mounted		\$1,200.00	\$1,560.00	
60" Flat Screen - 1080P, with Internal Speakers - Choose One: Table Top -or- Wall Mounted		\$1,400.00	\$1,820.00	
70" Flat Screen - 1080P, with Internal Speakers - Choose One: Table Top -or- Wall Mounted		\$1,800.00	\$2,340.00	
80" Flat Screen - 1080P, with Internal Speakers - Choose One: Table Top -or- Wall Mounted		\$2,800.00	\$3,640.00	
<i>Please call for pricing on Flat Screens 90" and larger, LED &amp; LCD Video Wall Options</i>		<i>Please call for pricing!</i>		

Flat Screen Accessories	QTY.	Early Order	Show Rate	Total
Mounting Bracket - (32" - 80" Flat Screen) *Only required if providing your own Flat Screen		\$150.00	\$195.00	
Single Post Stand - (up to 24" Flat Screen; Mounting Bracket Required - Charges May Apply)		\$150.00	\$195.00	
Dual Post Stand - (32" - 80" Flat Screen; Mounting Bracket Required - Charges May Apply)		\$225.00	\$292.50	

Touchscreen Displays	QTY.	Early Order	Show Rate	Total
32" Touchscreen - Choose One: Table Top -or- Wall Mounted		\$800.00	\$1,040.00	
46" Touchscreen - Choose One: Table Top -or- Wall Mounted		\$1,300.00	\$1,690.00	
<i>Please call for pricing on Touchscreens 65" and larger</i>		<i>Please call for pricing!</i>		

Computing	QTY.	Early Order	Show Rate	Total
Desktop Computer with Monitor (3.2 GHz or faster)		\$275.00	\$357.50	
Laptop Computer (Core i5/2.5ghz/4GB/300GBHD/DVD)		\$325.00	\$422.50	
Apple iPad		\$175.00	\$227.50	
iPad Floor Stand - White		\$150.00	\$195.00	
Apple 21.5" iMac (Intel Core 2 Duo/3.06 GHz)		\$300.00	\$390.00	
Apple 15" MacBook Pro (2.3 GHz Quad Core with Thunderbolt)		\$450.00	\$585.00	
Apple 17" MacBook Pro (2.3 GHz Quad Core with Thunderbolt)		\$550.00	\$715.00	

Additional Equipment	QTY.	Early Order	Show Rate	Total
USB Media Player		\$120.00	\$156.00	
Choose: Blu-ray -or- DVD Player		\$150.00	\$195.00	
Sound Bar - 2.1 Full Range, with Built-in Subwoofer		\$75.00	\$97.50	
Small High Performance PA System (2 speakers, 1 Mixer/Amp)		\$330.00	\$429.00	
Wireless Microphone - Choose One: Handheld -or- Headset -or- Lavalier		\$240.00	\$312.00	

Quoted Equipment	QTY.	Early Order	Show Rate	Total

**\*Early order rate is subject to a 30% increase when ordering equipment after September 27, 2019.**

Contact Your Freeman Representative	Total Your Order
MIMI TON <a href="mailto:mimi.ton@freeman.com">mimi.ton@freeman.com</a> Phone: 214.333.1817 Fax: 469.621.5608 Online at: <a href="http://www.freeman.com">www.freeman.com</a>	Equipment Sub-Total
<p><b>Don't see what you are looking for? Please call to discuss the options!</b></p>	<b>33% Handling Charge (\$212.00 Min)</b> Includes Delivery, Install & Dismantle
	<b>Added Labor to Mount Client Owned Flat Screen to Stand (\$75)</b>
	<b>State Rental Tax on Equipment Only (6.25%)</b>
	<b>TOTAL CHARGES:</b>
	<p><i>** Please note for Monitor Stand &amp; Mount Rentals: Additional labor may be required to mount client provided monitors ** Electrical Services are not included in equipment pricing.</i></p>

Please Fill in All Information Below Before Submitting Your Order

Contact Information

Your Name:	Booth Number:
Exhibiting Company Name:	
Company Address:	
City / State:	Zip Code:
Phone:	Fax:
Email:	
Third Party (If Applicable):	
Signature:	

Delivery Information

*A representative must be in your booth at the time of delivery unless alternate arrangements are made. Delivery subject to readiness of the booth structure and set-up. Please call us at 214.333.1817 with questions.*

On-Site Contact Person:	Cell Phone:	
Please Select Your Preferred Date and Time of Delivery (Choose One):		
Saturday, October 19, 2019	<input type="checkbox"/> 8am - 12pm	<input type="checkbox"/> 1pm - 5pm
Sunday, October 20, 2019	<input type="checkbox"/> 8am - 12pm	<input type="checkbox"/> 1pm - 2pm
If You Have a Special Delivery Request, Please Note it Here:		

Payment Information

Method of Payment (Choose One):

- Credit Card** \* In an effort to maximize the security of customer payments, a Freeman representative will include a link to our secure portal to provide credit card payment, with your order confirmation.
- Check** \*Checks must be in U.S. funds drawn on a U.S. or Canadian bank. "U.S. Funds" must be pre-printed on Canadian checks.
- Key Account** \*Key Account customers have been pre-approved with net 30 terms.
- Bank Transfer** \* Please reference the Show Name and Booth Number so we may properly credit your account.  
**Wire Transfer:** Bank Transfer to Bank of America, N.A.; Dallas, TX  
ABA#: 026-009-593, ACCT #: 4426831545 Freeman Audio Visual, Inc.  
Physical address routing identifiers: 100 West 33rd Street, New York, NY

**International Wire Transfer**  
Swift Code: BOFAUS3N ACCT # 4426831545 Freeman Audio Visual, Inc.  
CHIPS address: 0959 Freeman Audio Visual, Inc.  
Physical address for international routing identifiers: 100 West 33rd Street, New York, NY

**ACH Direct Deposit**  
ABA# 111-000-012 ACCT # 4426831545 Freeman Audio Visual, Inc.  
ABA routing transit number physical bank address: 901 Main Street, Dallas, TX

Note: Customers assume responsibility for any bank processing fees.

*\*\* For your convenience, Freeman will use your authorization to charge your credit card account for advanced and on site orders placed by your company representative. These charges may include all Freeman companies, or any charges which Freeman may be obligated to pay on behalf of the Exhibitor including without limitation, any shipping charges.*

*\*\* All payments must be made in advance in US funds.*

*\*\*Full payment, including any applicable tax, is due at the time the order is placed.*

**Cancellation Policy:** Any cancellation must be received within **7 days** of show open to avoid being charged one day's rental rate. Cancellations after delivery will result in a day's charge and labor incurred.

# PAYMENT & LABOR

## YOU ARE ENTERING A CONTRACT WHICH LIMITS YOUR POSSIBLE RECOVERY IN CASE OF LOSS OR DAMAGE.

The terms and conditions set forth below become a part of the Contract between FREEMAN and you, the EXHIBITOR. Acceptance of said terms and conditions will be construed when any of the following conditions are met:

- THE METHOD OF PAYMENT FORM IS SIGNED; OR
- AN ORDER FOR LABOR, SERVICES AND/OR RENTAL EQUIPMENT IS PLACED BY EXHIBITOR WITH FREEMAN; OR
- WORK IS PERFORMED ON BEHALF OF EXHIBITOR BY LABOR SECURED THROUGH FREEMAN.

## DEFINITIONS

For purposes of this Contract, "FREEMAN" or "The Freeman Companies" means Freeman Expositions, Inc., Freeman Expositions, Ltd., Freeman Audio Visual, Inc., Exhibit Surveys, Inc., Freeman Exhibit, Freeman Transportation, FreemanXP, Inc., Stage Rigging, Inc., The Freeman Company, Freeman Electrical, Inc., Freeman Digital Ventures, Inc., and their respective employees, directors, officers, agents, assigns, affiliated companies, and related entities including, but not limited to, any subcontractors FREEMAN may appoint. The term "EXHIBITOR" means the Exhibitor, its employees, agents, representatives, and any Exhibitor Appointed Contractors ("EAC").

## PAYMENT TERMS

Full payment, including any applicable tax, is due in advance or at show site. All payments must be in U.S. secure funds and all checks must be drawn on a U.S. bank. Orders received without advance payment or after the deadline date will incur additional charges as indicated on each order form. Payment for Audio Visual services and equipment is due in advance of move-in, unless otherwise agreed in writing with Freeman. All materials and equipment are on a rental basis for the duration of the show or event and remain the property of FREEMAN except where specifically identified as a sale. All rentals (excluding Audio Visual equipment and computers) include delivery, installation, and removal from EXHIBITOR'S booth. Rental prices on Audio Visual equipment and computers do not include labor, delivery, electrical services or removal of the equipment from the booth. In case of cancellation of any orders or services by EXHIBITOR, a one-hour "per person, per hour" charge will be applied for all labor orders that are not canceled in writing at least 24 hours prior to the scheduled start time. If Prestige Carpet, Custom-Cut Carpet, Modular Rental Exhibits and any other custom-order items or services have already been provided at the time of cancellation, fees will remain at 100% of the original charge. Audio Visual orders cancelled within 7 days from the show opening date will be charged a one-day rental rate on equipment. On-site cancellation of Audio Visual services will result in a one-day rental charge of equipment and any applicable labor. If the Show or Event is canceled because of reasons beyond FREEMAN'S control, EXHIBITOR remains responsible for all charges for services and equipment provided up to and including the date of cancellation. FREEMAN will not issue refunds to EXHIBITOR of any payments made before the date of cancellation. It is EXHIBITOR'S responsibility to advise the FREEMAN Service Center Representative of problems with any orders, and to check the EXHIBITOR'S invoice for accuracy prior to the close of the Show or Event. If EXHIBITOR is exempt from payment of sales tax, FREEMAN requires an exemption certificate for the State in which the services are to be used. Resale certificates are not valid unless EXHIBITOR is rebilling these charges to its customers. For International EXHIBITORS, FREEMAN requires 100% prepayment of advance orders, and any order or services placed at show site must be paid at the show. For all others, should there be any pre-approved unpaid balance after the close of the show; terms will be net, due and payable in DALLAS, TEXAS upon receipt of invoice. Effective 30 days after invoice date, any unpaid balance will bear a FINANCE CHARGE at the lesser of the maximum rate allowed by applicable law, or 1.5% per month, which is an ANNUAL PERCENTAGE RATE of 18%, and future orders will be on a prepaid basis only. If any finance charge hereunder exceeds the maximum rate allowed by applicable law, the finance charge shall automatically be reduced to the maximum rate allowed, and any excess finance charge received by FREEMAN shall be either applied to reduce the principal unpaid balance or refunded to the payer. If past due invoices or invoice balances are placed with a collection agency or attorney for collection or suit, EXHIBITOR agrees to pay all legal and collection costs. THESE PAYMENT TERMS AND CONDITIONS SHALL BE GOVERNED BY AND CONSTRUED IN ACCORDANCE WITH THE LAWS OF THE STATE OF TEXAS. In the event of any dispute between the EXHIBITOR and FREEMAN relative to any loss, damage, or claim, such EXHIBITOR shall not be entitled to and shall not withhold payment, or any partial payment, due to FREEMAN for its services, as an offset against the amount of any alleged loss or damage. Any claims against FREEMAN shall be considered a separate transaction, and shall be resolved on its own merits. FREEMAN reserves the right to charge EXHIBITOR for the difference between the EXHIBITOR'S estimate of charges and the actual charges incurred by EXHIBITOR, or for any charges that FREEMAN may be obligated to pay on behalf of EXHIBITOR, including without limitation, any shipping charges. If EXHIBITOR provides a credit card for payment and charges are rejected by the EXHIBITOR'S credit card company for any reason, FREEMAN hereby provides notice that it reserves the right, and EXHIBITOR authorizes FREEMAN, to continue to attempt to secure payment through that credit card for as long as unpaid balances remain on the EXHIBITOR'S account. In the event that a THIRD PARTY orders on behalf of the EXHIBITOR and the named THIRD PARTY does not discharge payment of the invoice prior to the last day of the show, charges will revert back to the EXHIBITOR. All invoices are due and payable upon receipt, by either party.

## ELECTRICAL

If FREEMAN provides electrical services, claims will not be considered, or adjustments made unless filed in writing, by EXHIBITOR, prior to the close of the event. FREEMAN is not responsible for any damage or loss caused by the loss of power beyond its control and EXHIBITOR agrees to hold FREEMAN, its officers, directors, employees and agents harmless from such power loss. IN NO EVENT SHALL FREEMAN BE LIABLE FOR ANY INDIRECT OR CONSEQUENTIAL DAMAGES (INCLUDING WITHOUT LIMITATION LOST PROFITS) EVEN IF ADVISED OF THE POSSIBILITY OF SUCH DAMAGES, WHETHER UNDER THEORY OF CONTRACT, TORT (INCLUDING NEGLIGENCE), PRODUCTS LIABILITY OR OTHERWISE. EXHIBITOR shall indemnify and hold harmless FREEMAN, its officers, directors, employees, and agents from and against any and all claims, liabilities, damages, fines, penalties or costs of whatsoever nature (including reasonable attorneys' fees) arising out of or in any way connected with EXHIBITOR'S actions or omissions under this Agreement. Please note that electrical services are NOT automatically included in Audio Visual rentals and must be ordered separately from the designated electrical provider.

## LABOR UNDER THE SUPERVISION OF EXHIBITOR RESPONSIBILITIES

EXHIBITOR shall be responsible for the performance of labor provided under this option. It is the responsibility of EXHIBITOR to supervise labor secured through FREEMAN in a reasonable manner as to prevent bodily injury and/or property damage and also to direct them to work in a manner that is in compliance with FREEMAN'S Safe Work Rules and/or Federal, State, County and Local ordinances, rules and/or regulations, including but not limited to Show or Facility Management rules and/or regulations. If any labor secured through Freeman is conducting overhead work, the Exhibitor is responsible for ensuring that everyone in the area of overhead work is wearing a hard hat. If the Exhibitor does not have its own hard hats, Freeman can assist with obtaining them. It is the responsibility of EXHIBITOR to check in with the Service Desk to pick up labor, and to return to the Service Desk to release labor when the work is completed.

## INDEMNIFICATION

EXHIBITOR agrees to indemnify, hold harmless, and defend FREEMAN from and against any and all demands, claims, causes of action, fines, penalties, damages, liabilities, judgments, and expenses (including but not limited to reasonable attorneys' fees and investigation costs) for bodily injury, including any injury to FREEMAN employees, and/or property damage arising out of work performed by labor provided by FREEMAN but supervised by EXHIBITOR. Further, the EXHIBITOR'S indemnification of FREEMAN includes any and all violations of Federal, State, County or Local ordinances, "Show Regulations and/or Rules" as published and/or set forth by Facility or Show Management, and/or directing labor provided by FREEMAN to work in a manner that violates any of the above rules, regulations, and/or ordinances.

## IMPORTANT

PLEASE REFER TO FREEMAN'S "MATERIAL HANDLING TERMS & CONDITIONS" AS IT RELATES TO MATERIAL HANDLING SERVICES AND TO THE "SERVICE REQUEST & SHIPPING INSTRUCTIONS CONTRACT" AS IT RELATES TO TRANSPORTATION SERVICES. CONTRACT TERMS DEPEND ON THE NATURE OF SERVICES SECURED BY EXHIBITOR THROUGH FREEMAN. TERMS & CONDITIONS MAY VARY FOR EACH TYPE OF SERVICE ORDERED THROUGH FREEMAN.

# MATERIAL HANDLING

**YOU ARE ENTERING A BINDING CONTRACT WHICH LIMITS YOUR POSSIBLE RECOVERY IN CASE OF LOSS OR DAMAGE.** Acceptance of said terms and conditions will be construed when any of the following conditions are met: This Material Handling Agreement (MHA) is signed; Exhibitor's materials are delivered to Freeman's warehouse or to an event site for which Freeman is the Official Show Contractor; or an order for labor and/or rental equipment is placed by Exhibitor with Freeman. Please be aware that disposal of exhibit properties is not included as part of your material handling charges. Please contact Freeman for your quoted rates and rules applicable to disposal of your exhibit properties.

**1. DEFINITIONS.** For purposes of this Contract, Freeman means Freeman Expositions, Inc., and its employees, directors, officers, agents, assigns, affiliated companies, and related entities. In no event shall Freeman be deemed to be the Ultimate Consignee for shipping and custom purposes. The term "Exhibitor" means the Exhibitor, its employees, agents, and representatives.

**2. PACKAGING/CRATES AND STORAGE.** Freeman shall not be responsible for damage to loose or uncrated materials, pad wrapped or shrink-wrapped materials, glass breakage, concealed damage, carpets in bags or poly, or improperly packed or labeled materials. Freeman shall not be responsible for crates and packaging which are unsuitable for handling, in poor condition, or have prior damage. Crates and packaging should be of a design to adequately protect contents for handling by forklift and similar means. Freeman does not accept any crates or packaging containing hazardous materials. Goods requiring cold storage and those in accessible storage are stored at Exhibitor's own risk. **FREEMAN ASSUMES NO RESPONSIBILITY OR LIABILITY FOR LOSS OR DAMAGE TO GOODS IN COLD STORAGE OR ACCESSIBLE STORAGE.**

**3. EMPTY CONTAINERS.** Empty container labels will be available at the show site service desk. Affixing labels to the containers is the sole responsibility of Exhibitor or its representative. All previous labels must be removed or obliterated. Freeman assumes no responsibility for: error in the above procedures; removal of containers with old empty labels and without Freeman labels; or improper information on empty labels. **FREEMAN WILL NOT BE LIABLE FOR LOSS OR DAMAGE TO CRATES AND CONTAINERS OR THEIR CONTENTS WHILE SAME ARE IN EMPTY CONTAINER STORAGE.**

**4. INBOUND/OUTBOUND SHIPMENTS.** There may be a lapse of time between the delivery of shipment(s) to the booth and the arrival of Exhibitor, or a lapse of time between the completion of packing and the actual pickup of materials from the booths for loading onto a carrier and during such times, Exhibitor materials will be left unattended. **FREEMAN IS NOT RESPONSIBLE OR LIABLE FOR ANY LOSS, DAMAGE, THEFT, OR DISAPPEARANCE OF EXHIBITOR'S MATERIALS AFTER THEY HAVE BEEN DELIVERED TO EXHIBITOR'S BOOTH AT SHOW SITE OR BEFORE THEY HAVE BEEN PICKED UP FOR RELOADING AT THE CONCLUSION OF THE EVENT.** Freeman recommends the securing of security services from Facility or Show Management. All MHA's submitted to Freeman by Exhibitor will be checked at the time of pickup from the booth and corrections will be made where discrepancies exist between the quantities of items on any form submitted to Freeman and the actual count of such items in the booth at the time of pickup. Freeman is not responsible for any wait time or other charges including business center charges arising from delivery or pickup of Exhibitor's materials.

**5. DELIVERY TO THE CARRIER FOR RELOADING.** Freeman assumes no responsibility for loss, damage, theft, or disappearance of Exhibitor's materials after same have been delivered to Exhibitor's appointed carrier, shipper, or agent for transportation after the conclusion of the show. Freeman loads the materials onto the carrier under directions from the carrier or driver of that carrier. Any loading onto the carrier will be understood to be under the exclusive supervision and control of the carrier or driver of that carrier. **FREEMAN ASSUMES NO RESPONSIBILITY FOR LOSS, DAMAGE, THEFT OR DISAPPEARANCE OF EXHIBITOR'S MATERIALS THAT ARISES OUT OF IMPROPERLY LOADED OR LABELED MATERIALS.**

**6. DESIGNATED CARRIERS.** Freeman shall have the authority to change the Exhibitor designated carrier if that carrier does not pick up the shipment(s) at the appointed time. Where no disposition is made by Exhibitor, materials may be taken to a warehouse to await Exhibitor's shipping instructions and Exhibitor agrees to be responsible for charges relating to such rerouting and handling. **IN NO EVENT SHALL FREEMAN BE RESPONSIBLE FOR ANY LOSS RESULTING FROM SUCH REROUTING DESIGNATION.**

**7. FORCE MAJEURE.** Freeman's performance hereunder is subject to, and Freeman shall not be responsible for loss, delay, or damage due to, strike, work stoppages, natural elements, vandalism, Act of God, civil disturbances, power failures, explosions, acts of terrorism or war, or for any other cause beyond Freeman's reasonable control, nor for ordinary wear and tear in the handling of Exhibitor's materials.

**8. CLAIM(S) FOR LOSS.** Exhibitor agrees that any and all claims for loss or damage must be submitted to Freeman immediately at the show site and in any case not later than **thirty (30) business days** after the date when Exhibitor's materials are delivered to the carrier for transportation from show site or from Freeman's warehouse. All claims reported after thirty (30) days will be rejected. In no event shall a suit or action be brought against Freeman **more than one (1) year** after the date of loss or damage occurred.

**a. PAYMENT FOR SERVICES MAY NOT BE WITHHELD.** In the event of any dispute between the Exhibitor and Freeman relative to any loss, damage, or claim, Exhibitor shall not be entitled to and shall not withhold payment due Freeman for its services as an offset against the amount of any alleged loss or damage. Any claims against Freeman shall be considered a separate transaction and shall be resolved on their own merits.

**b. MAXIMUM RECOVERY.** If found liable for any loss, Freeman's sole and exclusive maximum liability for loss or damage to Exhibitors materials and Exhibitor's sole and exclusive remedy is limited to \$50 (USD) per pound per article with a maximum liability of \$100.00 (USD) per item, or \$1,500.00 (USD) per shipment whichever is less. All shipment weights are subject to correction and final charges determined by the actual or re-weighted weight of the shipment.

**c. LIMITATION OF LIABILITY.** IN NO EVENT SHALL FREEMAN BE LIABLE TO THE EXHIBITOR OR TO ANY OTHER PARTY FOR SPECIAL, COLLATERAL, EXEMPLARY, INDIRECT, INCIDENTAL, OR CONSEQUENTIAL DAMAGES, WHETHER SUCH DAMAGES OCCUR EITHER PRIOR OR SUBSEQUENT TO, OR ARE ALLEGED AS A RESULT OF, TORTIOUS CONDUCT, FAILURE OF THE EQUIPMENT OR SERVICES OF FREEMAN OR BREACH OF ANY OF THE PROVISIONS OF THIS CONTRACT, REGARDLESS OF THE FORM OF ACTION, WHETHER IN CONTRACT OR IN TORT, INCLUDING STRICT LIABILITY AND NEGLIGENCE, EVEN IF FREEMAN HAS BEEN ADVISED OR HAS NOTICE OF THE POSSIBILITY OF SUCH DAMAGES. SUCH EXCLUDED DAMAGES INCLUDE BUT ARE NOT LIMITED TO LOST PROFITS, LOSS OF USE, AND INTERRUPTION OF BUSINESS OR OTHER CONSEQUENTIAL OR INDIRECT ECONOMIC LOSSES.

**9. DECLARED VALUE.** Declarations of Declared Value are between the Exhibitor and the selected Carrier ONLY, and are in no way an extension of Freeman's maximum liability stated herein. Freeman will use commercially reasonable efforts to transmit the Declared Value instructions to the selected Carrier; however, **FREEMAN WILL NOT BE LIABLE FOR ANY CLAIM ARISING FROM THE TRANSMITTAL OF, OR FAILURE TO TRANSMIT, DECLARED VALUE INSTRUCTIONS TO THE CARRIER NOR FOR FAILURE OF THE CARRIER TO UPHOLD THE DECLARED VALUE OR ANY OTHER TERM OF CARRIAGE.**

**10. JURISDICTION / VENUE.** THIS CONTRACT SHALL BE CONSTRUED UNDER THE LAWS OF THE STATE OF TEXAS WITHOUT GIVING EFFECT TO ITS CONFLICT OF LAWS RULES. EXCLUSIVE VENUE FOR ALL DISPUTES ARISING OUT OF OR RELATING TO THIS CONTRACT SHALL RESIDE IN A COURT OF COMPETENT JURISDICITON IN DALLAS COUNTY, TEXAS.

**11. INDEMNIFICATION.** Exhibitor agrees to indemnify and forever hold harmless Freeman from and against any and all demands, claims, causes of action, fines, penalties, damages (including consequential), liabilities, judgments, and expenses (including but not limited to reasonable attorneys' fees and investigation costs) arising out or contributed to by Exhibitor's negligent supervision of any labor secured through Freeman; Exhibitor's negligence, willful misconduct, or deliberate act, or the negligence, willful misconduct, or deliberate act of Exhibitor's employees, agents, representatives, customers, invitees and/or any Exhibitor Appointed Contractors (EAC) at the show or event to which this Contract relates, including but not limited to Exhibitor's violation of Federal, State, County or Local ordinance and/or Exhibitor's violation of Show Regulations and/or Rules as published and set forth by Facility and/or Show Management.

**12. LIEN.** Exhibitor grants Freeman a security interest in and a lien on all of Exhibitor's materials that is from time to time in the possession of Freeman and all the proceeds thereof, including without limitation insurance proceeds (the "Collateral"), to secure the prompt and full payment and performance of all Exhibitor's indebtedness for monies paid, by Freeman on its behalf, services performed, materials and/or labor from time to time provided by Freeman to or for the benefit of Exhibitor ("Obligations"). Freeman shall have all the rights and remedies of a secured party under the Uniform Commercial Code, as may be amended from time to time ("UCC"), and any notice that Freeman is required to give under the UCC of a time and place of a public sale or the time after which any private sale or other intended disposition of any Collateral is to be made shall be deemed to constitute reasonable notice if such notice is mailed by registered or certified mail at least five (5) days prior to such action. Freeman may hold and not deliver any of the Collateral to Exhibitor for so long as there are any Obligations that remain unpaid or unsatisfied.

**13. WAIVER & RELEASE.** Exhibitor, as a material part of the consideration to Freeman for material handling services, waives and releases all claims against Freeman with respect to all matters for which Freeman has disclaimed liability pursuant to the provisions of this Contract.

**14. DRIVER LIABILITY WAIVER.** IN CONSIDERATION OF FREEMAN PERMITTING ENTRANCE TO THE PREMISES, YOU, YOUR EMPLOYER, THE OWNER OF THE TRUCK AND/OR EQUIPMENT THAT YOU ARE OPERATING (TRUCKOWNER) AND YOU AS AGENT OF YOUR EMPLOYER AND THE TRUCKOWNER, HEREBY ASSUME ALL RISK OF INJURY OR HARM TO YOURSELF AND OTHERS AND DAMAGE TO YOUR PROPERTY AND PROPERTY BELONGING TO YOUR EMPLOYER OR OTHERS ARISING FROM YOUR ACTIVITIES WHILE BEING PERMITTED TO ENTER THE PREMISES. YOU AGREE TO ENTER AT YOUR OWN RISK. YOU HAVE FULL KNOWLEDGE OF ANY RISK INVOLVED IN THIS ACTIVITY. YOU RECOGNIZE THE HAZARDS AND ARE AWARE OF ALL THE RULES FOR SAFE OPERATION. YOUR EMPLOYER, THE TRUCKOWNER, AND YOU AGREE TO INDEMNIFY AND HOLD HARMLESS FREEMAN, ITS EMPLOYEES, OFFICERS, DIRECTORS, AGENTS, ASSIGNS, AFFILIATED COMPANIES AND RELATED ENTITIES, AGAINST ANY AND ALL LIABILITY, ACTIONS, CLAIMS, AND DAMAGES OF ANY KIND WHATSOEVER ARISING FROM YOUR ACTIVITIES WHILE BEING PERMITTED TO ENTER THE PREMISE.

# AIR CARGO

## AIR CARGO SERVICE REQUEST AND SHIPPING INSTRUCTIONS CONTRACT

In tendering this shipment, the Shipper and Consignee agree to these TERMS which no agent or employee of the parties may alter. This Air Service Request and Shipping Instruction Contract is NON-NEGOTIABLE and has been prepared by Shipper, or if by Freeman or another on Shipper's behalf, it shall be deemed, conclusively, to have been prepared by the Shipper. The Shipper agrees that this shipment is subject to the TERMS stated herein All TERMS, including but not limited to, all the limitations of liability, shall apply to our agents and their contracting carriers.

**1. DEFINITIONS:** In this Contract, "Freeman" means Freeman Decorating Services, Inc., and its respective employees, officers, directors, agents, assigns, affiliated companies, and related entities including any contractors appointed by Freeman. The term "Shipper" means the person or business for whom the property is being transported, and includes their respective employees, officers, directors, agents, assigns, affiliated companies, and contractors appointed by the Shipper, excluding only Freeman. "Property" is all objects of any type received from the Shipper for transport by Freeman as described herein. "Consignee" is the party to whom Shipper has designated the goods are to be delivered.

**2. FINAL CONTRACT BETWEEN THE PARTIES:** In exchange for Shipper's payments and Freeman's services, which the parties have specified in this two-page Contract (including the Air Cargo Service Request and Shipping Instructions), Freeman and Shipper each agree that this Contract shall govern their respective rights and obligations regarding transportation of Shipper's property. This Contract shall take effect when the property first comes into the physical possession of Freeman, and the responsibility of Freeman under same shall end when the property has been placed in the possession of the Consignee or the Consignee's designated agent. If any part or provision of this Contract is found by a court of competent jurisdiction to be void or unenforceable, the remainder of the Contract shall continue in full force and effect.

**3. Freeman's RESPONSIBILITIES UNDER THE CONTRACT ARE LIMITED:** Freeman is responsible for the satisfactory performance of only those services which it directly provides under this Contract. Freeman shall not be responsible for the performance of individuals of firms who are not under the direct supervision or control of Freeman. Freeman shall not be responsible for events or causes of loss, delay, or damage beyond its reasonable control, including (by way of illustration only, and not as a limitation on the breadth of this clause), strike, lockout, work slowdown or stoppage, power failure, breakdown of plant or machinery, facility failure, vandalism, theft, Act of God, effect of natural elements, riot, civil commotion or disturbance, terrorism, act of war or belligerent parties, and any other cause or causes beyond the reasonable control of Freeman. EXCEPT FOR ELIGIBLE GUARANTEED SERVICE SHIPMENTS, Freeman DOES NOT GUARANTEE DELIVERY BY ANY SPECIFIC TIME OR DATE.

**4. PACKAGING AND CRATES:** Shipper's property must be well packaged for safe and secure handling, storage and shipment using ordinary care. Each piece must be legibly and durably marked with the name and address, including correct ZIP code of the Shipper and Consignee. When a container is used repeatedly by Shipper, Shipper must remove all old labels, tags, markings, etc., and Shipper must ensure that the container retains adequate strength for transportation. Freeman makes neither representation nor any warranty regarding the acceptability or suitability of any packaging system or procedure that Shipper might use for its property. Freeman shall not be responsible for damage to loose or uncrated materials, padded or shrink-wrapped materials, glass breakage, concealed damage, carpets in bags or poly, or improperly packed or labeled materials. Crates and packaging should be of a design to adequately protect contents for handling by forklift and similar means. General guidance as to acceptable packaging systems and procedures may be found in publications such as the National Motor Freight Classification, published by the National Motor Freight Traffic Association. For shipments of Perishable Commodities, U.S. and Canadian shipments must be packed to travel without spoilage for 72 hours from time of pickup; all International shipments must be packed to travel without spoilage for 24 hours beyond an agreed deadline. Freeman reserves the right to periodically embargo regions of the world due to conditions that may cause damage to perishable commodities. If the integrity of a shipment is in question, Freeman reserves the right to improve packaging at shipper's expense.

**5. REFUSED SHIPMENTS:** If the Consignee refuses a shipment tendered for delivery or if Freeman is unable to deliver a shipment because of fault or mistake of the Consignor or Consignee, Freeman's liability shall then become that of a warehouseman.

- Freeman shall promptly attempt to provide notice, by telephonic, electronic or written communication as provided on the face of these shipping instructions, if so indicated, to Shipper or the party, if any, designated to receive notice in these instructions.
- Storage charges, based on Freeman's applicable rates, shall start no sooner than the next business day following the attempted notification. Storage may be, at Freeman's option, in any location that provides reasonable protection against loss or damage. Freeman may place the shipment in public storage at the owner's expense and without liability to Freeman.
- If Freeman does not receive disposition instructions within 48 hours of the time of Freeman's attempted first notification, Freeman will attempt to issue a second and final confirmed notification. Such notice shall advise that if Freeman does not receive disposition instructions within 10 days of that notification, Freeman may offer the shipment for sale at a public auction and Freeman has the right to offer the shipment for sale. The amount of sale will be applied to Freeman's invoice for transportation, storage and other lawful charges. Shipper will be responsible for the balance of charges not covered by the sale of the goods. If there is a balance remaining after all charges and expenses are paid, such balance will be paid to the owner of the property sold hereunder, upon claim and proof of ownership.
- Where Freeman has attempted to follow the procedure set forth above and the procedure is not possible, nothing shall be construed to abridge the right of Freeman, at its option, to sell the property under such circumstances and in such manner as may be authorized by law.
- When perishable goods cannot be delivered and disposition is not given within a reasonable time, Freeman may dispose of property to the best advantage. Where Freeman is directed by Consignee or Consignor to unload or deliver property at a particular location where Consignor, Consignee, or the Agent of either is not regularly located, Freeman's liability for the shipment shall terminate after unloading or delivery.

**6. LIMITATION ON SHIPPER'S RECOVERABLE DAMAGES:** FREEMAN'S LIABILITY FOR DAMAGES ON DOMESTIC SHIPMENTS, INCLUDING BUT NOT LIMITED TO THOSE DAMAGES ARISING FROM OR RELATED TO MISDELIVERY, INCOMPLETE OR OTHERWISE INADEQUATE DELIVERY (INCLUDING BUT NOT LIMITED TO FAILURE TO FOLLOW SHIPPER OR CONSIGNEE INSTRUCTIONS OR FAILURE TO COLLECT OR PROPERLY DELIVER A PAYMENT INSTRUMENT), NONDELIVERY, MISSED PICKUP, AND LOSS OF OR DAMAGE TO CARGO, SHALL BE LIMITED TO THE HIGHER OF \$50.00 (USD) PER SHIPMENT OR \$.50 (USD) PER POUND (\$1.10 (USD) PER KILOGRAM) OF CARGO ADVERSELY AFFECTED THEREBY, PLUS TRANSPORTATION CHARGES APPLICABLE TO THAT PART OF THE SHIPMENT ADVERSELY AFFECTED THEREBY, UNLESS AT TIME OF SHIPMENT THE SHIPPER MAKES A DECLARATION OF VALUE FOR CARRIAGE IN THE SPACE DESIGNATED ON THE SERVICE REQUEST AND SHIPPING INSTRUCTIONS FORM AND PAYS THE APPROPRIATE VALUATION CHARGE. IN NO EVENT SHALL FREEMAN'S LIABILITY EXCEED THE DECLARED VALUE OF THE SHIPMENT OR THE AMOUNT OF LOSS OR DAMAGE ACTUALLY SUSTAINED, WHICHEVER IS LOWER. IF CARRIAGE OF THE SHIPMENT IS SOLELY OR PARTLY BY AIR AND INVOLVES AN ULTIMATE DESTINATION OR A STOP IN A COUNTRY OTHER THAN THE COUNTRY OF DEPARTURE, Freeman's LIABILITY FOR CARGO LOST, DAMAGED OR DELAYED SHALL BE LIMITED TO \$9.07 PER POUND (\$20.00 PER KILOGRAM) FOR CARRIAGE SUBJECT TO THE UNAMENDED WARSAW CONVENTION OR THE WARSAW CONVENTION AS AMENDED BY THE HAGUE PROTOCOL OF 1955, 17 SPECIAL DRAWING RIGHTS PER KILOGRAM FOR CARRIAGE SUBJECT TO THE WARSAW CONVENTION AS AMENDED BY THE MONTREAL PROTOCOL NO. 4 OF 1975, OR \$9.07 PER POUND (\$20.00 PER KILOGRAM) FOR CARRIAGE WHERE THE WARSAW CONVENTION, INCLUDING ITS AMENDMENTS, DOES NOT APPLY FOR ANY REASON, UNLESS A HIGHER DECLARED VALUE IS REQUESTED, AND THE FEES SET FORTH IN THE SERVICE GUIDE FOR SUCH HIGHER DECLARED VALUE ARE PAID. FOR INTERNATIONAL SHIPMENTS, THIS SHIPPING REQUEST AND SHIPPING INSTRUCTION CONTRACT SHALL BE DEEMED AN AIR WAYBILL WITHIN THE MEANING OF THE WARSAW CONVENTION.

Notwithstanding the above limitations, domestic shipments containing the following items of extraordinary value are limited to a maximum declared value of \$500.00 (USD):

- artworks and objects of art, including without limitation original paintings, drawings, etchings, water colors, tapestries and sculpture;
  - clocks, watches, jewelry (including costume jewelry), furs and fur-trimmed clothing;
  - personal effects;
  - and other inherently fragile or unique items, including prototypes, etc.
- Any declared value in excess of the maximums allowed herein is null and void, and the acceptance by Freeman for carriage of any shipment with a declared value in excess of the allowed maximums does not constitute a waiver of these maximums. Shipper understands that even if Shipper is not able to participate or fully participate in a show due to loss of, theft of, or damage to its property, Freeman shall never be liable or responsible for damages identified by the terms (by way of example only and not in limitation of the breadth of this clause) such as the following: consequential damages, loss of use damages, loss of profits damages, business interruption damages, delay damages, special damages, collateral damages, exemplary damages, damages awarded for gross negligence, direct damages, indirect damages, damages for failure of performance, breach of contract damages, fraud damages, or any other sort of damage for tort or breach of contract. This limitation shall bind the parties:
- whenever or wherever the claimed loss or damage may occur;
  - even though the alleged loss or damage is claimed to result from negligence, strict liability, products liability, breach of contract, breach of statute or regulation, or any other legal theory or cause, and;
  - even though Freeman may have been advised or be on notice of the possibility or even the probability of such damages. Freeman makes no warranties, express or implied, and expressly disclaims any and all warranties. Except for Freeman's failure to deliver in accordance with the Guaranteed Service section of the Service Guide, Freeman will not be liable for misdelivery, incomplete or otherwise inadequate delivery (including but not limited to failure to follow Shipper or Consignee instructions or failure to collect or properly deliver a payment instrument), non-delivery, missed pickup, delay on International shipments, loss or damage unless caused by Freeman's sole negligence.

### 7. SHIPPER'S RESPONSIBILITIES AND INDEMNIFICATION:

- Shipper must pay in full for the services rendered under this Contract at the time the services are requested. The existence of a dispute between Shipper and Freeman relative to any claim or other matter shall have no bearing on this duty of payment. No claim submitted by or on behalf of Shipper will be processed unless Shipper's account is current.
- Shipper understands and acknowledges that Freeman does not accept or transport illegal, dangerous or hazardous materials of any kind or nature. Shipper warrants and ensures that its property is inert, and contains no Hazardous Substances, Hazardous Materials, Chemicals, Gases, Explosives, Radioactive Materials, Biologically hazardous agents, or any other substance, matter or object in any form that could pose a threat to the health or safety of persons, property or the public welfare in general. Such goods may be warehoused at owner's risk and expense or destroyed without compensation.
- Shipper shall defend and indemnify Freeman, its employees, directors, officers, and agents from and against any and all demands, claims, causes of action, fines, penalties, damages (including consequential), liabilities, judgments, and expenses (including but not limited to reasonable attorneys' fees and investigation costs) on account of personal injury, death, or damage to or loss of property or profits arising out of or contributed to by any of the following: Shipper's negligence, willful misconduct, or deliberate act; Shipper's violation of Federal, State, County or Local ordinances; Shipper's violation of Show Regulations and/or Rules as published and set forth by Facility and/or Show Management; and/or Shipper's failure to comply with (b) of this Agreement regarding the inclusion of any dangerous substances in the property placed with Freeman.

**8. CLAIMS:** Shipper, Consignee, or any other party claiming an interest in the shipment must notify Freeman immediately upon delivery, or in the case of loss or damage which could not have been noted at the time of delivery, within five (5) business days of delivery, of any loss or damage to the shipment. Notice of concealed damage must be confirmed in writing or via email at [exhibit.transportation@freeman.com](mailto:exhibit.transportation@freeman.com) within 5 business days of receipt of the property. If Carrier schedules an inspection, claimant must hold the shipping container, all packaging material and contents in the same condition as they were in when damage was discovered. Receipt of the shipment by the Consignee or the Consignee's agent without written notice on the delivery receipt and/or delivery manifest will be prima facie evidence that the shipment was delivered in good condition. The amount of the claim may not be deducted from the transportation charges. Notice of loss or damage MUST be reported to Freeman at 800-995-3579. The shipment, its container(s), and packing material must be made available to Freeman for inspection at the delivery location. All shipments are subject to opening for inspection by Freeman; however, Freeman is not obligated to perform such inspection. All claims for loss or damage MUST be made in writing to Freeman within one hundred and twenty (120) calendar days after the date of acceptance of the shipment by Freeman. Please refer to the Service Guide for claim procedures. All claims for service failure must be made within thirty (30) calendar days from the date of shipment and Freeman's sole liability for such claims arising from Guaranteed Service shipments shall be limited to the transportation charges as provided in the Guaranteed Service section of the Service Guide. All claims for overcharge must be made in writing to Freeman within sixty (60) calendar days after the invoice date. No claim for loss or damage may be maintained against Freeman unless (a) claimant complies with all requirements of this section and (b) for domestic shipments, if the claimant commences the action within one (1) year of the shipment by Freeman unless otherwise required by International, Federal or State Law. If the claim is for loss or damage involving International shipments, claimant must commence the action within two (2) years from the date of acceptance of the shipment by Freeman unless otherwise required by International, Federal or State Law. For purposes of this section, no action shall be deemed to have commenced until receipt by Freeman of service of process of the action on Freeman. Claims for loss or damage must be delivered to the following address: Sedgwick, PO Box 14151, Lexington, KY 40512-4151.

For shipping containers designed for repeated use (tradeshow cases, totes, crates), Freeman shall have no liability for superficial damage to said containers in the form of scuffs, scratches, dents or dings. Freeman will only accept liability for "catastrophic" damage to these shipping containers (crushing, puncture, or complete destruction). Freeman's maximum liability in cases of "catastrophic" damage or total loss will be limited to a depreciated value of the container based on the time elapsed from the original purchase and the purchase price established on the provided original invoice. This maximum liability will be subject to all other applicable limits of liability such as repair costs.

**9. CHOICE OF FORUM:** THIS CONTRACT SHALL BE CONSTRUED UNDER THE LAWS OF THE UNITED STATES (INCLUDING ADOPTED INTERNATIONAL CONVENTIONS) AND THE STATE OF TEXAS WITHOUT GIVING EFFECT TO THE STATE'S CONFLICT OF LAWS RULES. FREEMAN AND SHIPPER AGREE THAT ANY CLAIM OR DISPUTE OF ANY SORT ARISING OUT OF OR IN ANY WAY RELATED TO THIS CONTRACT, ITS PERFORMANCE OR NONPERFORMANCE, OR DAMAGES ALLEGEDLY RESULTING FROM SAME WILL BE ARBITRATED IN THE CITY OF DALLAS, TEXAS, AND THE RULES OF THE AMERICAN ARBITRATION ASSOCIATION WILL APPLY. IF BINDING ARBITRATION IS UNAVAILABLE TO RESOLVE ANY CONTROVERSY AND IT IS NECESSARY TO LITIGATE THE DISPUTE, THE DISPUTE SHALL BE LITIGATED IN A COURT OF COMPETENT JURISDICTION IN DALLAS COUNTY, TEXAS.

**10. MISCELLANEOUS:** Shipper warrants the accuracy of the weight and dimension data furnished in this Contract. Shipper understands that once its property is shipped by Freeman pursuant to the instructions contained in this Contract, Shipper has no right to control the shipment; stop the shipment in transit, or divert or reschedule same, and that Shipper will have no control over the property until it is delivered pursuant to the instructions in this Contract. Shipper agrees that this Contract may be provided to any third party, including common or contract carriers of cargo by air, water, rail, or road, for the purpose of confirming the right of Freeman to control the handling of the property and all matters related to payment for the shipment.

# MOTOR CARGO

## MOTOR CARGO SERVICE REQUEST AND SHIPPING INSTRUCTIONS CONTRACT

This Contract establishes your legal obligations with regard to the property described herein being shipped with Freeman Transportation. It specifically limits your rights and possible recovery if your property is lost or damaged. You must accept all terms and conditions of this Contract. You confirm that you have read and agree with all the terms and conditions of this Contract by receipt without contest. This Contract may not be waived or varied, except in writing, and then only by an authorized representative of Freeman.

**1. DEFINITIONS.** In this Contract, "Freeman" means Freeman Expositions, Inc., and its respective employees, officers, directors, agents, assigns, affiliated companies, and related entities including any contractors appointed by Freeman. The term "Shipper" means the person or business for whom the property is being transported, and includes their respective employees, officers, directors, agents, assigns, affiliated companies, and contractors appointed by the Shipper, excluding only Freeman. "Property" is all objects of any type received from the Shipper for transport by Freeman as described herein. "Consignee" is the party to whom Shipper has designated the goods are to be delivered.

**2. FINAL CONTRACT BETWEEN THE PARTIES.** In exchange for Shipper's payments and Freeman's services, which the parties have specified in this Contract, Freeman and Shipper each agree that this Contract shall govern their respective rights and obligations regarding transportation of Shipper's property. This Contract shall take effect when the property first comes into the physical possession of Freeman for inbound shipments and after loading on the applicable carrier for outbound shipments, and the responsibility of Freeman under same shall end when the property has been placed in the possession of the Consignee or the Consignee's designated agent. If any part or provision of this Contract is found by a court of competent jurisdiction to be void or unenforceable, the remainder of the Contract shall continue in full force and effect.

**3. FREEMAN'S RESPONSIBILITIES UNDER THE CONTRACT ARE LIMITED.** Freeman shall not be responsible for the performance of individuals or firms who are not under the direct supervision or control of Freeman. Freeman shall not be responsible for events or causes of loss, delay, or damage beyond its reasonable control, including (by way of illustration only, and not as a limitation on the breadth of this clause), strike, lockout, work slowdown or stoppage, power failure, breakdown of plant or machinery, facility failure, vandalism, theft, Act of God, effect of natural elements, riot, civil commotion or disturbance, terrorism, act of war or belligerent parties, and any other cause or causes beyond the reasonable control of Freeman. Freeman shall not be liable for delay caused by highway obstructions, or faulty or impassable highways, or lack of capacity of any highway, bridge, or ferry, or caused by breakdown or mechanical defects of vehicles or equipment, or from any cause other than the negligence of Freeman. Freeman shall not be bound to transport by any particular schedule, means, vehicle or otherwise, other than with reasonable dispatch.

**4. PACKAGING AND CRATES.** Shipper's property must be well packaged for safe and secure handling, storage and shipment using ordinary care. Freeman makes neither representation nor any warranty regarding the acceptability or suitability of any packaging system or procedure that Shipper might use for its property. Freeman shall not be responsible for damage to loose or uncrated materials, padwrapped or shrink-wrapped materials, glass breakage, concealed damage, carpets in bags or poly, or improperly packed or labeled materials. Crates and packaging should be of a design to adequately protect contents for handling by forklift and similar means. General guidance as to acceptable packaging systems and procedures may be found in publications such as the National Motor Freight Classification, published by the National Motor Freight Traffic Association. If the integrity of a shipment is in question, Freeman reserves the right to improve packaging at shipper's expense.

**5. PERISHABLE GOODS.** Goods of a perishable nature are carried in dry trailers without environmental or atmospheric control or other special services unless Shipper states on the face of the "Service Request and Shipping Instructions" that the goods are to be carried in a refrigerated, heated, specially ventilated or otherwise specially equipped trailer. This carriage may be subject to additional charges. Shipper is responsible for bringing the goods to the proper temperature before loading the goods into the trailer, for the proper stowage of the goods within the trailer, and for setting the temperature (including maintenance and repair), during all times after the trailer is spotted by Freeman and before the trailer is received by Freeman. Freeman is not responsible for product deterioration caused by inherent vice, defects in the merchandise or transit times in excess of product shelf life. Refrigerated, heated, specially ventilated or otherwise specially equipped trailers are not equipped to change the temperature of goods (they are equipped only to maintain temperature). Shipper will give written notice of requested temperature setting of the thermostatic controls before receipt of the goods by Freeman. When a loaded trailer is received, Freeman will verify that the thermostatic controls are set to maintain trailer temperature as requested. Freeman is unable to determine whether the goods were at the proper temperature when they were loaded into the trailer or when the trailer is delivered to Freeman. Air temperature at the unit sensor will be maintained within a proper range of plus or minus 5 degrees Fahrenheit of the temperature requested by Shipper on the face of the "Service Request and Shipping Instructions" if the goods were at that temperature when loaded into the container and if the temperature controls were properly set when the container was loaded.

**6. REFUSED SHIPMENTS.** If the Consignee refuses a shipment tendered for delivery or if Freeman is unable to deliver a shipment because of fault or mistake of Freeman, Freeman's liability shall then become that of a warehouseman.

(a) Freeman shall promptly attempt to provide notice, by telephonic, electronic or written communication as provided on the face of these shipping instructions, if so indicated, to Shipper or the party, if any, designated in these instructions to receive notice.

(b) Storage charges, if applicable, shall start no sooner than the next business day following the attempted notification. Storage may be, at Freeman's option, in any location that provides reasonable protection against loss or damage. Freeman may place the shipment in public storage at the owner's expense and without liability to Freeman.

(c) If Freeman does not receive disposition instructions within 48 hours of the time of Freeman's attempted first notification, Freeman will attempt to issue a second and final confirmed notification. Such notice shall advise that if Freeman does not receive disposition instructions within 10 days of that notification, Freeman may offer the shipment for sale at a public auction and Freeman has the right to offer the shipment for sale. The amount of sale will be applied to Freeman's invoice for transportation, storage and other lawful charges. Shipper will be responsible for the balance of charges not covered by the sale of the goods. If there is a balance remaining after all charges and expenses are paid, such balance will be paid to the owner of the property sold hereunder, upon claim and proof of ownership.

(d) Where Freeman has attempted to follow the procedure set forth above and the procedure is not possible, nothing shall be construed to abridge the right of Freeman, at its option, to sell the property under such circumstances and in such manner as may be authorized by law.

(e) When perishable goods cannot be delivered and disposition is not given within a reasonable time, Freeman may dispose of property to the best advantage. When Freeman is directed by Consignee or Consignor to unload or deliver property at a particular location where Consignor, Consignee, or the Agent of either is not regularly located, Freeman's liability for the shipment shall terminate after unloading or delivery.

**7. INSURANCE. Freeman IS NOT AN INSURER.** Shipper is responsible for obtaining insurance for its property. Freeman provides no insurance for Shipper or its property.

**8. LIMITATION ON SHIPPER'S RECOVERABLE DAMAGES.** Shipper understands that even if shipper's property is lost, stolen, or damaged, Freeman does not pay replacement or restoration cost of any property. **FREEMAN'S MAXIMUM LIABILITY SHALL BE THE AMOUNT OF PROVEN ACTUAL VALUE NOT EXCEEDING THE LOWER OF FAIR MARKET VALUE.**

**(THE "FAIR MARKET VALUE" EQUALS THE AS IS WHERE IS PRICE FOR THE PROPERTY AT THE LOCATION OF THE SHOW TO WHICH PRICE A WILLING BUYER AND A WILLING SELLER WOULD AGREE IN AN ORDINARY COURSE OF BUSINESS, ARM'S LENGTH SALE.) OR \$5.00 (USD) PER POUND OF CARGO LOST OR DAMAGED UNLESS AT THE TIME OF SHIPMENT SHIPPER MAKES A DECLARATION OF VALUE FOR CARRIAGE IN THE SPACE DESIGNATED ON THE SHIPPING INSTRUCTIONS AND PAYS THE APPROPRIATE VALUATION CHARGE.** Even if Shipper has made a declaration of value, liability shall never exceed the depreciated original invoice value or the fair market value of the property, whichever is less. The value per pound for applying declared valuation charges shall be determined by dividing Shipper's declared value for carriage by the actual weight of the shipment. In all cases not prohibited by law, where a lower value than the actual value of the said property has been stated in writing by Shipper or has been agreed upon in writing as the released value of the property upon which the rate is based, such lower value plus freight charges, if paid, shall be the maximum recoverable amount for loss or damage. **Notwithstanding the above limitations, all shipments containing the following items of extraordinary value are limited to a maximum declared value of \$500.00 (USD):** (a) Artworks and objects of art, including without limitation, original paintings, drawings, etchings, watercolors, tapestries and sculptures or prototypes; (b) Clocks, jewelry, including costume jewelry, furs, and fur-trimmed clothing; (c) Personal effects, including without limitation, papers and documents; or (d) Coin money, currency, gift certificates, debit cards, credit cards, and any other items of extraordinary value. (e) For either unmarked, unlabeled, or improperly packaged television monitors, the maximum liability is the lesser of \$3.00 (USD) per pound or the actual invoice price.

Any declared value in excess of the maximums allowed herein is null and void, and the acceptance by Freeman of carriage of any shipment with a declared value in excess of the allowed maximums does not constitute a waiver of these maximums. In any event, (excluding small package program shipments) **Freeman's MAXIMUM LIABILITY WILL NEVER BE MORE THAN \$100,000 PER SHIPMENT.** Shipper understands that even if Shipper is not able to participate or fully participate in a Show due to loss of, theft of, or damage to their property, Freeman shall not be liable or responsible for damages identified by the terms (by way of example only and not in limitation of the breadth of this clause) such as the following: consequential damages, loss of use damages, loss of profits damages, business interruption damages, delay damages, special damages, collateral damages, exemplary damages, damages awarded for gross negligence, direct damages, indirect damages, or damages for failure of performance, breach of contract damages, fraud damages, or any other sort of damage for tort or breach of contract. This limitation shall bind the parties: **(a) WHENEVER OR WHEREVER THE CLAIMED LOSS OR DAMAGE MAY OCCUR; (b) EVEN THOUGH THE ALLEGED LOSS OR DAMAGE IS CLAIMED TO RESULT FROM NEGLIGENCE, STRICT LIABILITY, PRODUCTS LIABILITY, BREACH OF CONTRACT, BREACH OF STATUTE OR REGULATION, OR ANY OTHER LEGAL THEORY OR CAUSE, AND; (c) EVEN THOUGH FREEMAN MAY HAVE BEEN ADVISED OR BE ON NOTICE OF THE POSSIBILITY OR EVEN THE PROBABILITY OF SUCH DAMAGES.**

### 9. SHIPPER'S RESPONSIBILITIES AND INDEMNIFICATION:

(a) Shipper must pay in full for the services rendered under this Agreement at the time the services are requested. The existence of a dispute between Shipper and Freeman relative to any claim or other matter shall have no bearing on this duty of payment. No claim may be submitted by or on behalf of Shipper to Freeman unless Shipper's account is current.

(b) Shipper understands and acknowledges that Freeman does not accept or transport illegal or hazardous materials of any kind or nature. Shipper warrants and will ensure that its property is inert, and contains no Hazardous Substances, Hazardous Materials, Chemicals, Gasses, Explosives, Radioactive Materials, Biologically hazardous agents, or any other substance, matter or object in any form that could pose a threat to the health or safety of Freeman persons, property, or the public welfare in general. Such goods may be warehoused at owner's risk and expense or destroyed without compensation.

(c) Shipper shall defend and indemnify Freeman, its employees, directors, officers, and agents from and against any and all demands, claims, causes of action, fines, penalties, damages (including consequential), liabilities, judgments, and expenses (including but not limited to reasonable attorneys' fees and investigation costs) on account of personal injury, death, or damage to or loss of property or profits arising out of or contributed to by any of the following: Shipper's negligence, willful misconduct, or deliberate act; Shipper's violation of Federal, State, County or Local ordinances; Shipper's violation of Show Regulations and/or Rules as published and set forth by Facility and/or Show Management; and/or Shipper's failure to comply with subsection (b) of this section regarding the inclusion of any dangerous substances in the property placed with Freeman.

**10. CLAIMS.** Claims must be filed in writing within nine (9) months after the date of delivery of the property (or in the case of export traffic, within nine (9) months after delivery at the port of export), except that claims for failure to make delivery must be filed within nine (9) months after a reasonable time for delivery has elapsed. Suits for loss, damage, or delay shall be instituted against Freeman no later than two (2) years and one (1) day from the day when written notice is given by Freeman to the claimant that Freeman has disallowed the claim or any part or parts of the claim specified in the notice. Shipper shall deliver notice of claim for loss or damage by hand, U.S. mail, courier, facsimile, or electronic means to Sedgwick, PO Box 14151, Lexington, KY 40512-4151 as soon as loss or damage is discovered. The notice of claim shall invite a prompt joint survey of the damage, at a time and place to be agreed between the parties, and such survey shall go forward promptly. However, if in any case the property is received by the Consignee or the Consignee's agent without notice of loss or damage to property being served on Freeman within 5 business days of the receipt of the property, it is agreed between Freeman and Shipper that in that instance the presumption shall arise that the property was delivered in proper quantity and in good condition. Notice of concealed damage must be confirmed in writing or via email at [exhibit.transportation@freeman.com](mailto:exhibit.transportation@freeman.com) within 5 business days of receipt of the property. If Carrier schedules an inspection, claimant must hold the shipping container, all packaging material and contents in the same condition as they were in when damage was discovered. Claims filed more than nine (9) months following the date on which the property was delivered or should have been delivered are agreed to be forever time barred.

For shipping containers designed for repeated use (tradeshow cases, totes, crates), Freeman shall have no liability for superficial damage to said containers in the form of scuffs, scratches, dents or dings. Freeman will only accept liability for "catastrophic" damage to these shipping containers (crushing, puncture, or complete destruction). Freeman's maximum liability in cases of "catastrophic" damage or total loss will be limited to a depreciated value of the container based on the time elapsed from the original purchase and the purchase price established on the provided original invoice. This maximum liability will be subject to all other applicable limits of liability such as repair costs.

**11. CHOICE OF FORUM / ARBITRATION.** THIS CONTRACT SHALL BE CONSTRUED UNDER THE LAWS OF THE STATE OF TEXAS WITHOUT GIVING EFFECT TO ITS CONFLICT OF LAWS RULES. EXCLUSIVE VENUE FOR ALL DISPUTES ARISING OUT OF CONTRACT, TORT, COMMON LAW OR RELATING TO THE ENFORCEMENT OR INTERPRETATION OF THIS CONTRACT SHALL RESIDE IN A COURT OF COMPETENT JURISDICTION IN DALLAS COUNTY, TEXAS. Notwithstanding anything herein to the contrary, any controversy or claim arising out of or relating to this Agreement, or the breach thereof, shall be exclusively settled by arbitration administered by the American Arbitration Association in accordance with its Commercial Arbitration Rules and judgment on the award rendered by the arbitrator(s) may be entered by any court having jurisdiction thereof.

**12. MISCELLANEOUS.** (a) Shipper warrants the accuracy of the weight and dimension data furnished in this Contract; (b) Shipper understands that once its property is shipped by Freeman pursuant to the instructions contained in this Contract, Shipper has no right to control the shipment, stop the shipment in transit, or divert or reschedule same. (c) Shipper agrees that this Contract may be provided to any third party, including common or contract carriers of cargo by air, water, rail, or road, for the purpose of confirming the right of Freeman to control the handling of the property and all matters related to payment for the shipment. Shipper agrees that all shipments are subject to correction and final charges determined by the actual or re-weighed weight of the shipment.

**13. SMALL PACKAGE PROGRAM.** If items shipped via Freeman's Small Packages program are lost, damaged or destroyed while in Freeman's possession, **FREEMAN'S MAXIMUM LIABILITY SHALL BE \$100 per package UNLESS AT THE TIME OF SHIPMENT SHIPPER MAKES A DECLARATION OF VALUE IN THE SPACE DESIGNATED ON THE SHIPPING INSTRUCTIONS AND PAYS THE APPROPRIATE VALUATION CHARGE.** If small packages are received by the Shipper and notice of loss or damage is not received by Freeman within 15 days of the delivery of the property, the parties agree that the presumption shall arise that the property was delivered in proper quantity and in good condition.

FREEMAN®

*furnishings 2019*





## **EMPOWERING YOUR BUSINESS FROM THE GROUND UP**

Meaningful engagement doesn't have to be complicated. You just need the right elements. Whether you're a global brand testing a new product, a startup seeking exposure, or an organization needing flexibility, the furnishings to create a dynamic brand experience start here. **To learn more about our exhibit solutions, go to [freeman.com/exhibit-design](http://freeman.com/exhibit-design)**

**It's not about building a booth.  
It's about designing a**

*beacon*

# Fairfax Sofa & La Brea Chairs

10'x10' Booth

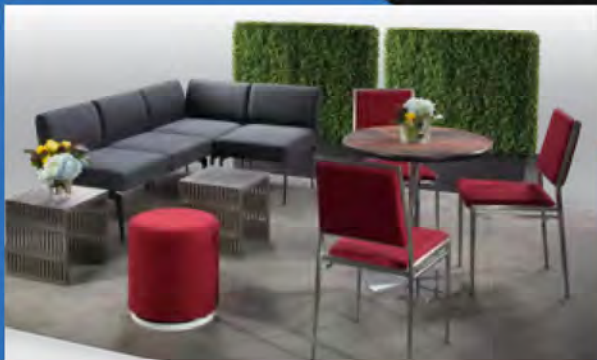

10'x10' Munich Sectional Booth



10'x20' Malba Café & Bench Theater Booth

# Power Up In Style.

Denotes Powered Products



## ROMA

**81021 Chair, Powered**  
(white vinyl) 37"L 31"D 33"H



## ROMA

**83017 Sofa, Powered**  
(white vinyl) 78"L 31"D 33"H

## HEDGE

**4 ft 85035**  
**4' Boxwood Hedge**  
46"L 9"D 47"H



## WIRELESS CHARGING TABLE, POWERED

**820710**  
(white, ac plug-in)  
20"L 20"D 18"H



## Powered Seating

Empower attendees at your next show with functional charging furniture and make searching for wall outlets history. From soft seating and tables to pedestals and lamps, our complete charging collection lets you Power Up the Possibilities.

# Powered Seating



**A) 810120**  
**Naples Chair, Powered**  
 (black vinyl)  
 36" L 30" D 33.25" H

**B) 830121**  
**Naples Sofa, Powered**  
 (black vinyl)  
 87" L 30" D 33.25" H

**C) 830122**  
**Naples Loveseat, Powered**  
 (black vinyl)  
 62" L 30" D 33.25" H

# Powered Tables



**Ventura Powered Bar Tables**  
 72.25" L 26.25" D 42" H  
 (silver frame)  
**A) 820955** (white top)  
**B) 820950** (black top)

**Ventura Powered Café Tables**  
 72.25" L 26.25" D 30" H  
 (silver frame)  
**C) 820964** (black top)  
**D) 820965** (white top)



**Sydney Powered Cocktail Tables**  
 48" L 26" D 18" H  
 (brushed steel)  
**E) 82073** (white)  
**F) 82076** (black)

**Please Note:** Client is responsible for providing labor and an electrical power source to the furniture. One 110V power source is required for each charging panel. Two charging units can be daisy chained together. 10A max per charging panel.

# Powered Banquettes.

Denotes Powered Products



## Modular System

Create round banquettes or custom serpentine seating. The Power Banquette system has three AC and two USB plugs built into the center cone so your client will never be left powerless. Center power cone may also be rented as a free-standing charging station.



POWERED  
DETAIL

Detail of Electrical  
Charging Outlet



**Full Banquette**  
w/ Electrical Charging Outlet  
(white vinyl)  
72"RND 51"H



**8506 Center Cone**  
w/ Electrical Charging Outlet  
(white vinyl)  
38"RND 51"H



**8507 Quarter Curve Ottoman**  
(white vinyl)  
53"L 22"D 18"H



**Ottoman Ring**  
(4 curve ottoman seats)  
(white vinyl)  
72"RND 18"H

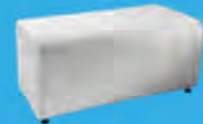

**815119 Half Bench Ottoman**  
(white vinyl)  
39"L 22"D 18"H

# Powered Pedestals



Denotes AC and USB charging outlets 

## Powered Locking Pedestal

- (white)
- A) 85061** 24" L 24" D 36" H
- B) 85063** 24" L 24" D 42" H (black)
- C) 85060** 24" L 24" D 36" H
- D) 85062** 24" L 24" D 42" H

## Wireless Charging Table, Powered

- E) 820710** (white, AC plug-In)
- 20" L 20" D 18" H

**Please Note:** Client is responsible for providing labor and an electrical power source to the furniture. One 110V power source is required for each charging panel. Two charging units can be daisy chained together. 10A max per charging panel.

# Powered Tech Desk



## A) 84083 Tech Desk, Powered w/3 Drawer File Cabinet

(black metal, laminate)  
60" L 30" D 30" H

## B) 84084 Tech Desk, Powered

(black metal, laminate)  
60" L 30" D 30" H

## C) 84080 3 Drawer File Cabinet on Castors

(black metal, laminate)  
16" L 20" D 28" H

# Soft Seating

*Create Engaging Booth Environments*

## HOPI

(gray linen)  
**810140, Chair**  
21"L 25"D 34"H  
**830150, Loveseat**  
48"L 25"D 34"H



## HEDGE

**7 ft 85030**  
**7' Boxwood Hedge**  
36.5"L 12"D 84"H

## PEDESTAL

**85063**  
**Powered Locking**  
(white)  
24"L 24"D 42"H

## CAFÉ TABLE

**8201223**  
**Hydraulic Chrome Base**  
(laminated white top)  
30" Round 29"H

## REGIS

**82075 End Table**  
(brushed metal)  
16"L 15.5"D 16.5"H

## MARCHE

**815159 Swivel Ottoman**  
(blue fabric)  
17" RND 18"H



10'x20' Hopi Lounge & Zenith Café Booth

# Soft Seating Collections

Available in Power 

A.



B.



C.



## BAJA

**A) 81050 Chair**  
(white vinyl)  
36"L 30.5"D 28"H

**B) 83019 Sofa**  
(white vinyl)  
86"L 28"D 30"H

**C) 83020 Loveseat**  
(white vinyl)  
61"L 30.5"D 28"H

A.



B.



## FAIRFAX

**A) 830949 Sofa**  
(white vinyl, brushed metal)  
62"L 26"D 30"H

**B) 810949 Chair**  
(white vinyl, brushed metal)  
27"L 26"D 30"H

A.



B.



C.



## NAPLES

**A) 810119 Chair**  
(black vinyl)  
36"L 30"D 33.25"H  
**810120** (Powered)

**B) 830119 Sofa**  
(black vinyl)  
87"L 30"D 33.25"H  
**830121** (Powered)

**C) 830120 Loveseat**  
(black vinyl)  
62"L 30"D 33.25"H  
**830122** (Powered)

# Munich Collection

*Modular Seating to Design Custom Exhibits*

Denotes Powered Products



## MUNICH

**830201 Sectional 3pc.**  
(gray fabric)  
93.5"L 27"D 28.5"H



## HEDGE

**4 ft 85035**  
**4' Boxwood Hedge**  
46"L 9"D 47"H

 **WIRELESS CHARGING TABLE, POWERED**

**820710**  
(white, ac plug-in)  
20"L 20"D 18"H

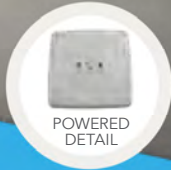

**830200 Munich Armless Loveseat**  
(gray fabric)  
45"L 27"D 28.5"H



**810150 Munich Corner Chair**  
(gray fabric)  
26"L 27"D 28.5"H



**810151 Munich Armless Chair**  
(gray fabric)  
22.5"L 27"D 28.5"H

# Soft Seating Collections



A.



B.



A.



B.



C.

## ALLEGRO

- A) 81019 Chair**  
(blue fabric)  
36"L 34.5"D 30"H
- B) 83015 Sofa**  
(blue fabric)  
73"L 34.5"D 30"H

## TANGIERS

- A) 830118 Sofa**  
(beige textured)  
78"L 37"D 36"H
- B) 810118 Chair**  
(beige textured)  
34"L 37"D 36"H
- C) 830220 Loveseat**  
(beige textured)  
57.5"L 37"D 37"H

## KEY LARGO

- A) 810950 Chair**  
(black fabric)  
35"L 35"D 34"H
- B) 830950 Loveseat**  
(black fabric)  
57"L 35"D 34"H
- C) 830951 Sofa**  
(black fabric)  
79"L 35"D 34"H

## SOUTH BEACH

- (platinum suede)
- A) 8301 Sofa**  
69"L 29"D 33"H
- B) 8151 Ottoman**  
25"L 31"D 18"H



A.



B.



C.



A.



B.

# Accent Chairs



## SWANSON

**810875 Swivel Chair**  
(white vinyl)  
28" L 25" D 30" H

## KEY WEST

**8103 Chair**  
(black)  
31" L 31" D 31" H



## LA BREA

**810874 Chair**  
(charcoal gray, fabric)  
35" L 27" D 40" H



## WENTWORTH

**810145 Chair**  
(brown vinyl)  
32.1" L 26" D 31.5" H

## AURA

**820844 Round Table**  
(white metal)  
15" Round 22" H



# Accent Chair Styles



A.



B.



C.



D.



E.



F.

## Madrid Chair

**A) 81816**  
(white vinyl)  
30"L 30"D 31"H

**B) 8102**  
(black vinyl)  
30"L 30"D 31"H

**C) 810949**  
**Fairfax Chair**  
(white vinyl, brushed metal)  
27"L 26"D 30"H

**D) 810151**  
**Munich Armless Chair**  
(gray fabric)  
22.5"L 27"D 28.5"H

**E) 810140**  
**Hopi Chair**  
(gray linen)  
21"L 25"D 34"H

**F) 810947**  
**Pro Executive Guest Chair**  
(black vinyl)  
24"L 22"D 36"H

# Meeting & Stage Chairs



A.



B.



C.



D.



E.



F.

## Marina Chair

17.5"L 19.5"D 35"H  
**A) 810160** (black vinyl)  
**B) 810161** (brown fabric)  
**C) 810164** (white vinyl)

## Meeting Chair

25.5"L 23.5"D 34"H  
**D) 810835** (espresso vinyl)  
**E) 810836** (taupe fabric)  
**F) 810948** (white vinyl)

# Group Seating

## ZENITH

**A) 810851 Chair**  
(white, chrome)  
18.25"L 22"D 32"H

**B) 820241  
Madison Hydraulic  
Café Table**  
(chrome base, gray  
acajou top)  
30"RND 29"H



## LAGUNA

**C) 810861 Chair**  
(maple, chrome)  
18"L 19"D 34"H

**D) 8201223  
Round Café Table**  
(white laminate top,  
chrome hydraulic base)  
30" Round 29"H



## MALBA

20"L 20"D 32"H

**A) 810131 Chair** (gray)  
**B) 810130 Chair** (green)

## MARINA

17.5"L 19.5"D 35"H

**A) 810164** (white vinyl)  
**B) 810160** (black vinyl)  
**C) 810161** (brown fabric)  
**D) 810162** (ocean blue fabric)  
**E) 810163** (red fabric)



# Styles & Shapes



A.



B.



C.



D.



E.



F.



G.



H.



I.

**A) 810810  
Berlin Chair**  
(black, white)  
18"L 22"D 32"H

**B) 810846  
Christopher Chair**  
(white vinyl, chrome)  
17"L 19"D 35"H

**C) 810841  
Rustique Chair w/arms**  
(gunmetal)  
20"L 18"D 31"H

**D) 81063  
Altura Guest Chair**  
(black crepe)  
25"L 20"D 34"H

**E) 71089  
Diamond Side Chair**  
(black)  
21"W X 23" L X 32"H

**F) 71090  
Diamond Arm Chair**  
(black)  
20"W X 21"L X 33"H

**G) 810837  
Razor Armless Chair**  
(white)  
15.38"L 15.5"D 30.5"H

**H) 81083  
Blade Chair**  
(sky blue)  
20.5"L 19"D 30.5"H

**I) 81082  
Blade Chair**  
(red)  
20.5"L 19"D 30.5"H

## Mix & Match

Create the ultimate seating configuration. Choose from a variety of shapes and sizes to design the perfect look.

**J) 210108 LIMERICK® Chair BY HERMAN MILLER™**  
(gray) 18"W X 17.75"L X 33"H

**K) 81093 Lucent Chair** (frosted, acrylic) 19.5"L 19.75"D 32.5"H



# Ottomans

## Vibe Cube

18"L 18"D 18"H

- A) 81531 (white vinyl)
- B) 81530 (black vinyl)
- C) 81532 (steel blue vinyl)
- D) 81534 (purple vinyl)
- E) 81533 (silver vinyl)
- F) 81519 (red vinyl)
- G) 81517 (yellow vinyl)
- H) 81520 (pink vinyl)
- I) 81518 (blue vinyl)
- J) 81525 (orange vinyl)



D.



E.



F.



G.



H.



I.



J.



# Styles & Shapes



**Beverly Bench**  
60"L 20"D 18"H  
**A) 81556** (white vinyl)  
**B) 81550** (black vinyl)  
**C) 81552** (gray fabric)  
**D) 81555** (red fabric)  
**E) 81554** (ocean blue fabric)  
**F) 81553** (linen fabric)  
**G) 81551** (brown fabric)

**H) 815119 Half Bench**  
(white vinyl)  
39"L 22"D 18"H

**ENDLESS Square**  
34"L 34"D 15"H  
**I) 815123** (black)  
**J) 815122** (white)  
**ENDLESS Curved**  
60.5"L 37.5"D 15"H  
**K) 815952** (black)  
**L) 815953** (white)

**M) 8507 Quarter Curve**  
(white vinyl)  
53"L 22"D 18"H  
**Ring** (4 ottoman seats)  
(white vinyl)  
72"RND 18"H

**N) 81526 Edge LED Cube**  
(white plastic)  
19"L 19"D 19"H  
A/C power only

**O) 82074 Regis Bench**  
(brushed metal)  
47"L 15.5"D 16"H

# Marche Swivel



**Marche Swivel Ottomans**  
17"RND 18"H  
**A) 815150** (white vinyl)  
**B) 815154** (red fabric)  
**C) 815158**  
(pear yellow fabric)  
**D) 815156** (plum fabric)  
**E) 815159** (blue fabric)  
**F) 815151** (gray fabric)  
**G) 815155**  
(rose quartz fabric)  
**H) 815152** (linen fabric)  
**I) 815153**  
(raspberry fabric)  
**J) 815157**  
(meadow green fabric)  
**K) 815160**  
(orange fabric)

# Accent Tables

## ALONDRA

### Cocktail Table

47"L 24"D 16"H

A) 820250 (glass, chrome)

B) 820251 (wood, chrome)



B.



C.



D.



## ALONDRA

### End Table

20"L 20"D 20"H

C) 820252 (glass, chrome)

D) 820253 (wood, chrome)

## GEO

### Cocktail Table

50"L 22"D 16"H

A) 82034 (glass, chrome)

B) 82027 (wood, black)



B.



C.



D.



## GEO

### End Table

26"L 26"D 20"H

C) 82035 (glass, chrome)

D) 82028 (wood, black)

# Styles & Shapes

Available in Power 

## Sydney Cocktail Tables

(brushed steel)  
48"L 26"D 18"H

- A) 82053 (white)
- 82073 (Powered)
- B) 82052 (black)
- 82076 (Powered)
- C) 82077 (blue)
- D) 82078 (wood)

## Sydney End Tables

27"L 23"D 22"H

- E) 82055 (white)
- F) 82054 (black)
- G) 82079 (blue)
- H) 82080 (wood)

## Regis Tables

(brushed metal)

- I) 82074 Bench Table  
47"L 15.5"D 16"H
- J) 82075 End Table  
16"L 15.5"D 16.5"H

## Silverado Tables

(glass, chrome)

- K) 82015 End Table  
24" Round 22"H
- L) 82014 Cocktail Table  
36" Round 17"H

## Oliver Tables

(walnut finish)

- M) 82088 End Table  
22" Round 22"H
- N) 82087 Cocktail Table  
47"L 27"D 19"H

## Aura Round Table

O) 82084

(white metal)  
15" Round 22"H

## Edge LED Cube Table

P) 82057

(plexi top, white plastic)  
20"L 20"D 20"H  
A/C power only

## Wireless Charging

Table, Powered

Q) 820710

(white, AC plug-In)  
20"L 20"D 18"H



# Café Tables

**A) 820940 Blue Hydraulic  
Café Table**  
(chrome base, blue top)  
30" RND 29" H

**B) 810131 Malba Chair**  
(gray)  
20" L 20" D 32" H



**7 ft 85030  
7' Boxwood Hedge**  
36.5" L 12" D 84" H



**30" Round Café Tables**

**A) 898240  
Standard Black Base**  
(red top) 30" RND 29" H

**B) 898895 Lucent Chair**  
(frosted, acrylic)  
19.5" L 19.75" D 32.5" H



**A) 820241 Madison  
Hydraulic Café Table**  
(chrome base, gray acajou top)  
30" RND 29" H

**B) 810130 Malba Chair**  
(green)  
20" L 20" D 32" H



# Customize and Create

Choose your base, black or chrome, then pick a color that suits your design.



**Café Tables**  
**Standard Black Base**  
 30" RND 29"H

**A) 8201220** (white)  
 also available  
**820265** (Madison/gray acajou)  
**820941** (blue)  
**820943** (wood)

**Café Tables**  
**Hydraulic Chrome Base**  
 30" RND 29"H

**B) 820923** (graphite nebula)  
 also available  
**8201208** (maple)  
**820921** (red)  
**820940** (blue)  
**820942** (wood)  
**820925** (silver)  
**8201223** (white)

# Mix & Match

Create your look. Choose from a wide variety of tables and seating options.



**C) 72063 Chelsea butcher block-top cafe table**  
 (oak) 30"RND 30"H  
 also available  
**72064** 36"RND 30"H

**D) 810164 Marina Chair**  
 (white vinyl) 17.5"L 19.5"D 35"H

36" RND 29"H  
**820126** (white)  
**8201209** (graphite nebula)  
**8201206** (maple)

**E) 72069 SOHO Series Black Top Café**  
 (black) 24"RND 30"H  
 also available  
**72067** 36"RND 30"H | **72066** 18"RND 18"H

**F) 81082 Blade Chair**  
 (red) 20.5"L 19"D 30.5"H



# Bar Tables

**A) 8201222**  
**30" Round Bar Table**  
(white top, chrome hydraulic base)  
30" RND 45"H

**B) 810952**  
**Apex Barstool**  
(blue ultra suede)  
21"L 21"D 33"H



**C) 8201226**  
**Rustique Square Metal Bar Table**  
(gunmetal)  
23.75"L 23.75"D 41.25"H

**D) 810839**  
**Rustique Barstool**  
(gunmetal)  
13"L 13"D 30"H



**E) 820930**  
**30" Round Bar Table**  
(blue top, chrome hydraulic base)  
30" RND 45"H

**F) 810860**  
**Laguna Barstool**  
(maple, chrome)  
18"L 20"D 47"H



**G) 820240 30"**  
**Round Bar Table**  
**w/ Hydraulic Chrome Base**  
(Madison/gray acajou)  
30" RND 45"H

**H) 810850**  
**Zenith Barstool**  
(white, chrome)  
19"L 20"D 44"H



# Customize and Create

Choose your base, black or chrome, then pick a color that suits your design.



## Bar Tables

**Standard Black Base**  
30" RND 42"H

- A) 8201221 (white)  
also available
- 820264 (Madison/gray acajou)
- 820931 (blue)
- 820933 (wood)

## Bar Tables

**Hydraulic Chrome Base**  
30" RND 45"H

- E) 820922 (graphite nebula)  
also available
- 8201207 (maple)
- 820920 (red)
- 820930 (blue)
- 820932 (wood)
- 802924 (silver)

- 36" RND 45"H
- 820125 (white)
- 8201211 (graphite nebula)
- 8201205 (maple)

# Style & Design

Choose from a variety of table top colors and styles for the perfect look.



**C) 720163 Chelsea butcher block-top bistro**  
(oak) 30"RND 42"H  
also available  
720164 36"RND 42"H

**D) 81092 Lucent Barstool**  
(frosted, acrylic) 22"L 22.5"D 45.5"H

**E) 72070 SOHO blacktop bistro**  
(black) 24"RND 42"H  
also available  
72068 36"RND 42"H

**F) 810953 Apex Barstools**  
(red vinyl) 21"L 21"D 33"H



# Barstools



## LIFT Barstools

15" Round 23–33.5"H

A) 810870 (white vinyl)

B) 810873 (red vinyl)

C) 810871 (black vinyl)

D) 810872 (gray vinyl)

# Styles & Shapes



A.



B.



C.



D.



E.



F.



G.



H.



I.



J.



K.



L.



M.



N.



O.



P.



Q.



R.



S.



T.

U.

## Mix & Match

- T) 720163 Butcher Block-Top Bistro (oak) 30" L RND 42" H  
also available 720164 36" RND 42" H
- U) 210109 LIMERICK® Stool BY HERMAN MILLER™ (white) 18" X 17.75" L X 44" H

### Apex Barstools

- 21" L 21" D 33" H
- A) 810951 (black vinyl)
- B) 810953 (red vinyl)
- C) 810954 (white vinyl)
- D) 810952 (blue ultra suede)

### Zoey Barstools

- 15" L 16" D 30-34.75" H
- E) 810840 (white, chrome)
- F) 810834 (black, chrome)

### Banana Barstools

- 21" L 22" D 41.75" H
- G) 810104 (black, chrome)
- H) 810103 (white, chrome)

### I) 810201 Oslo Barstool

- (white)
- 17" L 20" D 45" H

### J) 810848 Christopher Barstool

- (white vinyl, chrome)
- 19" L 15" D 41" H

### K) 810202 Shark Barstool

- (white, chrome)
- 22" L 19" D 34-44" H

### L) 810850

- Zenith Barstool
- (white, chrome)
- 19" L 20" D 44" H

### M) 81092

- Lucent Barstool
- (frosted, acrylic)
- 22" L 22.5" D 45.5" H

### N) 810860

- Laguna Barstool
- (maple, chrome)
- 18" L 20" D 47" H

### Blade Barstool

- 20.5" L 20.125" D 40.5" H
- O) 81080 (red)
- P) 81081 (sky blue)

### Q) 71088

- Black Diamond Stool
- (black) 22" W X 18" L X 46" H

### R) Gas Lift Stool w/ arms

- 24" W X 20" L X 46" H
- 71048 (gray, adjustable)
- also available
- 71047 w/o arms

### S) 810839

- Rustique Barstool
- (gunmetal) 13" L 13" D 30" H

# Conference Tables

A.



B.



**42" Round Conference Table**  
42" RND 29"H  
A) 820708 (white laminate)  
B) 820260 (Madison/gray acajou)

D.



C.



## MADISON

(Madison/gray acajou)

C) 820261 5' Table

60"L 48"D 29"H

D) 820262 8' Table

96"L 60"D 29"H

E) 820263 10' Table

120"L 48"D 29"H

E.



# Styles & Shapes

A. | B.



C.



D.



E.



F.



G.



H.



I.



## Atomic Round Tables

- (glass, chrome)
- A) 8201225** 42" RND 30"H
- B) 8201224** 36" RND 30"H

## Geo Rounded Square Tables

- 42"L 42"D 29"H
- C) 82044** (glass, chrome)
- D) 82043** (glass, black)

## Geo Rectangular Tables

- 60"L 36"D 29"H
- E) 82041** (glass, black)
- F) 82051** (glass, chrome)

## G) 820707 Merlin

- Multi Use Table**
- (gray laminate, black)
- 46"L 29"D 30"H

## H) 820706 Work Table

- (white laminate, white)
- 48"L 24"D 30"H

## I) 820203

### 6' Conference Tables

- (graphite nebula)
- 72"L 42"D 29"H

## Mix & Match

- J) 810946 Pro Executive High Back Chair** (black vinyl) 25"L 24"D 48"H Adjustable
- K) 810945 Pro Executive Mid Back Chair** (white vinyl) 24"L 22"D 40"H Adjustable



# Executive Seating

## Pro Executive High Back Chair

25"L 24"D 48"H  
**A) 810844** (white vinyl)  
**B) 810946** (black vinyl)  
 Adjustable height



## Task Stool

**810135**  
 (black fabric)  
 27.5"L 27.5"D  
 Adjustable height



## Pro Executive Guest Chair

24"L 22"D 36"H  
**810947** (black vinyl)



## Gas Lift Chair

26" X 20" L X 38" H  
**A) 71045** (gray, adjustable)  
**71046** w/ arms

## Gas Lift Stool

24" W X 20" L X 46" H  
**B) 71048** (gray, adjustable)  
**71047** w/o arms



## Pro Executive Mid Back Chair

24"L 22"D 40"H  
**A) 810945** (white vinyl)  
**B) 810944** (black vinyl)  
 Adjustable height



# Communal and Powered Tables

Choose from a variety of Powered, Solid or Grommet Hole Table Tops.

Denotes AC and USB charging outlets 



POWERED  
DETAIL



BLACK

WHITE

MAPLE

## Table Top Options

Colors not available in all table options. Please check options listed to the right.

## Bar Tables



A. 

**810860**  
**Laguna Barstool**  
(maple, chrome)  
18"L 20"D 47"H



B.



C.

### Ventura Powered Bar Tables

(silver frame)  
72.25"L 26.25"D 42"H

**A) 820950** (black top)  
**820955** (white top)

### Ventura Communal Bar Tables

(silver frame)  
72.25"L 26.25"D 42"H

Maple Top  
**B) 820954** (solid)  
**820951** (grommets)

White Top  
**C) 820953** (grommets)  
**820956** (solid)

Black Top  
**820952** (solid)

## Café Tables



A. 



C.



D.



B.



E.

### Ventura Powered Café Tables

(silver frame)  
72.25"L 26.25"D 30"H

**A) 820964** (black top)  
**B) 820965** (white top)

### Ventura Communal Café Tables

(silver frame)  
72.25"L 26.25"D 30"H

Maple Top  
**C) 820963** (solid)  
**820960** (grommets)

White Top  
**D) 820961** (grommets)  
**820966** (solid)

Black Top  
**E) 820962** (solid)

# Office Essentials

## MADISON

**A) 84075 Madison Executive Desk**

(gray acajou) 60"L 30"D 29"H

**B) 84077 Madison Credenza**

(gray acajou) 60"L 20"D 29"H

**C) 810135 Task Stool**

(black fabric)

27.5"L 27.5"D 32.75"-40.25"H Adjustable

**D) 810844 Pro Executive**

**High Back Chair**

(white classic vinyl)

25"L 24"D 48"H Adjustable



A.

DESK FRONT



B.

CREDENZA FRONT

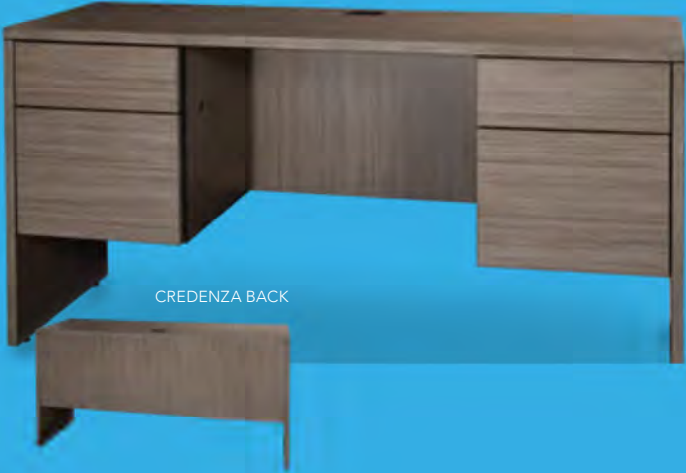

# Tech Powered Desk

Denotes AC and USB charging outlets 



**A) 84083 Tech Desk, Powered, w/3 Drawer File Cabinet**  
(black metal, laminate)  
60"L 30"D 30"H

**B) 84084 Tech Desk, Powered**  
(black metal, laminate)  
60"L 30"D 30"H

**C) 84080 3 Drawer File Cabinet on Castors**  
(black metal, laminate)  
16"L 20"D 28"H

# Lighting & Shelving



## ACCENT LAMPS

**Mason Lamps**  
(brushed silver)  
**A) 850708 Floor Lamp**  
18" RND 55"H  
**B) 850707 Table Lamp**  
16" RND 26"H

## SHELVING

**C) 85020 Posh Shelving**  
(chrome, acrylic)  
36"L 18"D 72"H  
**D) 84078 Madison Bookcase**  
(gray acajou)  
36"L 12"D 72"H

# Show Essentials

Denotes AC and USB charging outlets



## Midtown Powered Counter

Metallic pewter gray curved counter with taupe-colored glass top features two AC & three USB charging outlets, locking storage cabinet and two shelves.



### Midtown Powered Counter

60"L 18"D 42"H (pewter/glass)

850103 (unlighted)

850102 (lighted with plug-in)

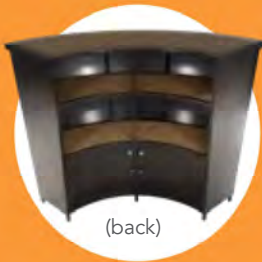

(back)



810860

Laguna Barstool

(maple, chrome)

18" L 20" D 47" H



7ft 85030

7' Boxwood Hedge

36.5"L 12"D 84"H

## Display Counter

A) 72056

Display Counter

(black)

24"W X 49"L X 42"H

B) 210109

limerick Stool

BY HERMAN MILLER™

(white)

18" X 17.75" L X 44" H

B.



A.



# Midtown Bar

Metallic pewter gray curved bar with taupe-colored glass top features locking cabinet for storage and two shelves.

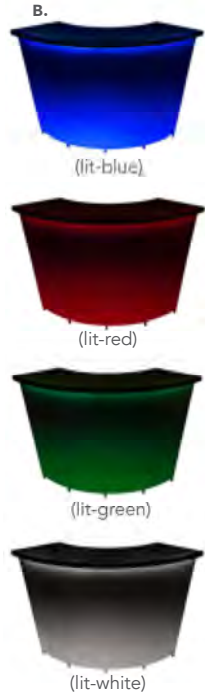

**Midtown Bar**  
60"L 18"D 42"H  
(pewter)  
**A) 850101**  
(unlighted)  
**B) 850100**  
(lighted with plug-in)

**Apex Barstool**  
**C) 810952**  
(blue ultra suede)  
21"L 21"D 33"H

# Lighted & Greenery Products

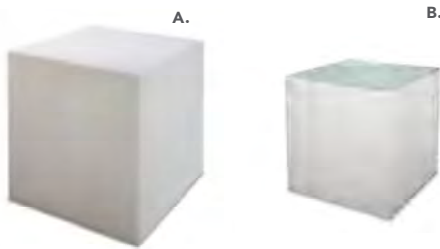

LED light available in white, red, green, blue and rolling color.

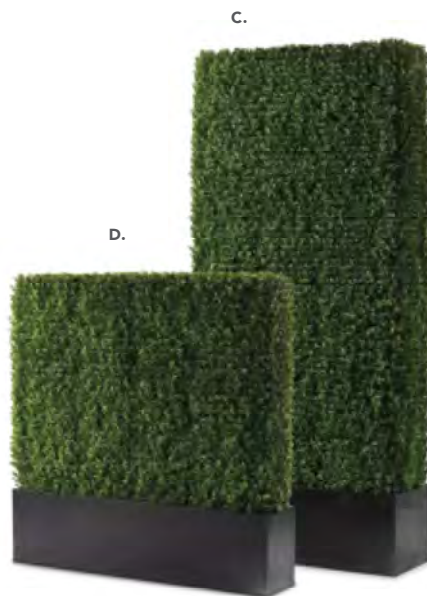

**A) 81526 Edge LED Cube Ottoman**  
(white plastic)  
20"L 20"D 20"H  
A/C power only  
**B) 820857 Edge LED Cube Table**  
(plexi top, white plastic)  
20"L 20"D 20"H  
A/C power only

**C) 7 ft 85030**  
**7' Boxwood Hedge**  
36.5"L 12"D 84"H  
**D) 4 ft 85035**  
**4' Boxwood Hedge**  
46"L 9"D 47"H

# Draped or Undraped Tables & Counters

## Table-top Colors



**Special Draping:** Special drape is available in a variety of colors. Refer to the order form for details. Table-top risers are available in a variety of sizes. See order form for details.

Visit us at [freeman.com](http://freeman.com) for ordering and full product line



## Sizing Chart\*

\*Table and counter widths are available in select cities

### 24"D X 30"H | Tables Draped

<b>124330</b>	Tables Draped	<b>3'L</b> x 24"D x 30"H
<b>124430</b>	Tables Draped	<b>4'L</b> x 24"D x 30"H
<b>124630</b>	Tables Draped	<b>6'L</b> x 24"D x 30"H
<b>124830</b>	Tables Draped	<b>8'L</b> x 24"D x 30"H

### 24"D X 30"H | Tables Undraped

<b>125330</b>	Tables Undraped	<b>3'L</b> x 24"D x 30"H
<b>125430</b>	Tables Undraped	<b>4'L</b> x 24"D x 30"H
<b>125630</b>	Tables Undraped	<b>6'L</b> x 24"D x 30"H
<b>125830</b>	Tables Undraped	<b>8'L</b> x 24"D x 30"H

### 30"D X 30"H | Tables Draped

<b>130330</b>	Tables Draped	<b>3'L</b> x 30"D x 30"H
<b>130430</b>	Tables Draped	<b>4'L</b> x 30"D x 30"H
<b>130630</b>	Tables Draped	<b>6'L</b> x 30"D x 30"H
<b>130830</b>	Tables Draped	<b>8'L</b> x 30"D x 30"H

### 30"D X 30"H | Tables Undraped

<b>131330</b>	Tables Undraped	<b>3'L</b> x 30"D x 30"H
<b>131430</b>	Tables Undraped	<b>4'L</b> x 30"D x 30"H
<b>131630</b>	Tables Undraped	<b>6'L</b> x 30"D x 30"H
<b>131830</b>	Tables Undraped	<b>8'L</b> x 30"D x 30"H

### 24"D X 42"H | Counter Draped

<b>124342</b>	Counter Draped	<b>3'L</b> x 24"D x 42"H
<b>124442</b>	Counter Draped	<b>4'L</b> x 24"D x 42"H
<b>124642</b>	Counter Draped	<b>6'L</b> x 24"D x 42"H
<b>124842</b>	Counter Draped	<b>8'L</b> x 24"D x 42"H

### 24"D X 42"H | Counter Undraped

<b>125342</b>	Counter Undraped	<b>3'L</b> x 24"D x 42"H
<b>125442</b>	Counter Undraped	<b>4'L</b> x 24"D x 42"H
<b>125642</b>	Counter Undraped	<b>6'L</b> x 24"D x 42"H
<b>125842</b>	Counter Undraped	<b>8'L</b> x 24"D x 42"H

### 30"D X 42"H | Counter Draped

<b>130342</b>	Counter Draped	<b>3'L</b> x 30"D x 42"H
<b>130442</b>	Counter Draped	<b>4'L</b> x 30"D x 42"H
<b>130642</b>	Counter Draped	<b>6'L</b> x 30"D x 42"H
<b>130842</b>	Counter Draped	<b>8'L</b> x 30"D x 42"H

### 30"D X 42"H | Counter Undraped

<b>131342</b>	Counter Undraped	<b>3'L</b> x 30"D x 42"H
<b>131442</b>	Counter Undraped	<b>4'L</b> x 30"D x 42"H
<b>131642</b>	Counter Undraped	<b>6'L</b> x 30"D x 42"H
<b>131842</b>	Counter Undraped	<b>8'L</b> x 30"D x 42"H

### 4th Side | Table Draped 30"

<b>12404630</b>	Drape Table 4th Side	<b>6'</b> X 30"
<b>12404830</b>	Drape Table 4th Side	<b>8'</b> X 30"

### 4th Side | Table Draped 42"

<b>12404642</b>	Drape Table 4th Side	<b>6'</b> X 42"
<b>12404842</b>	Drape Table 4th Side	<b>8'</b> X 42"

# Product Display

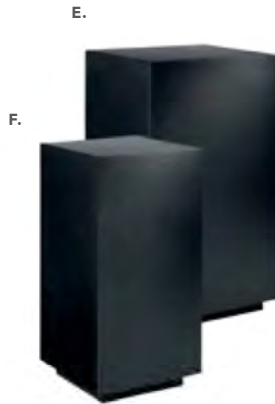

**A) 72056**  
**Display Counter**  
 (black)  
 24"W X 49"L X 42"H

**B) 75079**  
**Orion Computer Kiosk**  
 (black)  
 28"L X 28"D X 40.5"H  
 (computer not included)

**C) 810840**  
**Zoey Barstools**  
 (white, chrome)  
 15"L 16"D 30-34.75"H

**D) 75032**  
**Diplay Cube - Large**  
 (black)  
 24"W X 24"L X 42"H

**E) 75031**  
**Diplay Cube - Medium**  
 (black)  
 18"W X 18"L X 36"H

**F) 75030**  
**Diplay Cube - Small**  
 (black)  
 12"W X 12"L X 42"H

**G) 75022**  
**Diplay Cylinder - High**  
 (black)  
 24"W X 24"L X 36"H

**H) 75021**  
**Diplay Cylinder - Medium**  
 (black)  
 18"W X 18"L X 20"H

**I) 75020**  
**Diplay Cylinder - Low**  
 (black)  
 30"W X 12"L X 15"H  
 available in rectangle sizes

**J) 810947**  
**Pro Executive Guest Chair**  
 (black vinyl)  
 24"L 22"D 36"H

# Product Storage



## RACKS

**A) 750135**  
**Round Literature Rack**  
(black)  
17"W X 17"L X 57"H

**B) 750136**  
**Flat Literature Rack**  
(black)  
10"W X 55"H

## CABINETS

**C) 84080**  
**3 Drawer File Cabinet**  
**on Castors**  
(black metal, laminate)  
16"L 20"D 28"H

**D) 74082**  
**2 Drawer File Cabinet**  
**w/Lock**  
(tan metal)  
15"W X 29"L X 28"H

**E) 74081**  
**4 Drawer File Cabinet**  
**w/Lock**  
(tan metal)  
15"W X 29"L X 50"H



## REFRIGERATORS

**F) 8503001**  
**Large Refrigerator**  
(white) 14.0 cubic feet  
28"W X 28"L X 64"H

**G) 8983000**  
**Small Refrigerator**  
(brown) 4.0 cu feet  
20"W X 22"L X 33"H

# Show & Office Accessories

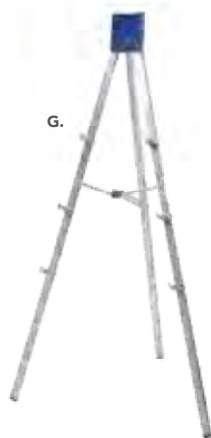

**A) 10201484**  
**Floor Standing**  
**Bulletin Board**  
 (black)  
 48"W X 96"L X 78"H

**B) 71048**  
**Gas Lift Stool w/ arms**  
 (gray, adjustable)  
 24"W X 20"L X 46"H  
 also available  
**71047 w/o arms**

**C) 220121**  
**Chrome Stanchion**  
**w/ 8' Retractable Belt**  
 (black, belt) 42"H

**D) 220110**  
**Chrome Bag Rack**  
 (3" at center)  
 1"W X 41"H X 26"W

**E) 220109**  
**Chrome Coat Tree**  
 (21" w at the base)  
 8 1/4"W X 69 1/2"H

**F) 220118**  
**Chrome Sign Holder**  
 (sign holds)  
 22"W X 28"H

**G) 220143**  
**Brushed Aluminum Easel**  
 (open 5 1/4"W X 64 1/4"H)  
 26"W X 62"H

**H) 220106**  
**Corrugated Wastebasket**  
 (black)



## Nationwide Service

**24 hours a day, 7 days a week, 365 days a year. Visit us at [freeman.com](http://freeman.com) or call 1.888.508.5058 for customer service.**

FREEMAN® Trade Show Furnishings is proud to offer this collection of the highest quality, design-oriented furnishings. Our nationwide distribution and professional staff is dedicated to the success of your exhibit. Make FREEMAN® Trade Show Furnishings your furniture solution.

# FREEMAN

275 Bodwell St  
Avon, MA 02322  
(508) 894-5100 Fax: (469) 621-5608



ONLINE PRICE  
DISCOUNT PRICE  
DEADLINE DATE

SEPTEMBER 27, 2019

INCLUDE THE FREEMAN METHOD OF  
PAYMENT FORM WITH YOUR ORDER

NAME OF SHOW: **AFP 2019 / OCTOBER 20-23, 2019**

COMPANY NAME: \_\_\_\_\_ BOOTH #: \_\_\_\_\_ BOOTH SIZE: **X**

CONTACT NAME : \_\_\_\_\_ PHONE #: \_\_\_\_\_

E-MAIL ADDRESS : \_\_\_\_\_

For Assistance, please call (508) 894-5100 to speak with one of our experts.

For fast, easy ordering, go to [www.freeman.com](http://www.freeman.com)

Qty	Part #	Description	Online Price	Discount Price	Standard Price	Total
<b>SOFT SEATING</b>						
<b>Naples Group - Black Vinyl</b>						
	810119*	Chair.....	601.20	661.30	841.70	_____
	830120*	Loveseat.....	800.10	880.10	1,120.15	_____
	830119*	Sofa.....	890.40	979.45	1,246.55	_____
<b>Munich Group - Gray Fabric</b>						
	810150*	Corner Chair.....	552.25	607.50	773.15	_____
	810151*	Armless Chair.....	482.05	530.25	674.85	_____
	830200*	Armless Loveseat.....	809.65	890.60	1,133.50	_____
	830201*	Sectional - 3 Piece.....	1,843.90	2,028.30	2,581.45	_____
<b>Baja Group - White Vinyl</b>						
	81050*	Chair.....	549.90	604.90	769.85	_____
	83020*	Loveseat.....	585.00	643.50	819.00	_____
	83019*	Sofa.....	753.75	829.15	1,055.25	_____
<b>South Beach Group - Platinum Suede</b>						
	8301*	Sofa.....	775.70	853.25	1,086.00	_____
	8151*	Ottoman.....	338.20	372.00	473.50	_____
<b>Key Largo Group - Black Fabric</b>						
	830950*	Loveseat.....	470.35	517.40	658.50	_____
	830951*	Sofa.....	521.80	574.00	730.50	_____
	810950*	Chair.....	372.05	409.25	520.85	_____
<b>Allegro Group - Blue Fabric</b>						
	81019*	Chair.....	498.70	548.55	698.20	_____
	83015*	Sofa.....	795.90	875.50	1,114.25	_____
<b>Fairfax Group - White Vinyl</b>						
	810949*	Chair.....	313.55	344.90	438.95	_____
	830949*	Sofa.....	500.75	550.85	701.05	_____
<b>Hopi Group - Gray Linen</b>						
	810140*	Chair.....	208.25	229.10	291.55	_____
	830150*	Loveseat.....	317.30	349.05	444.20	_____
<b>Tangiers Group - Beige Fabric</b>						
	810118*	Chair.....	526.40	579.05	736.95	_____
	830220*	Loveseat.....	680.95	749.05	953.35	_____
	830118*	Sofa.....	743.05	817.35	1,040.25	_____
<b>CASUAL SEATING</b>						
<b>Ottomans</b>						
	815122*	Endless Square - White Vinyl.....	370.05	407.05	518.05	_____
	815123*	Endless Square - Black Vinyl.....	370.05	407.05	518.05	_____
	815953*	Endless Curve - White Vinyl.....	485.90	534.50	680.25	_____
	815952*	Endless Curve - Black Vinyl.....	485.90	534.50	680.25	_____
	815119*	Half-Bench - White Vinyl.....	329.95	362.95	461.95	_____
	81518*	Vibe Cube - Blue Vinyl.....	131.05	144.15	183.45	_____
	81519*	Vibe Cube - Red Vinyl.....	131.05	144.15	183.45	_____

FREEMAN furnishings

Take advantage of the Online price  
by ordering at [www.freeman.com](http://www.freeman.com) before  
SEPTEMBER 27, 2019

NAME OF SHOW: **AFP 2019 / OCTOBER 20-23, 2019**

COMPANY NAME: \_\_\_\_\_ BOOTH #: \_\_\_\_\_ BOOTH SIZE: X

CONTACT NAME : \_\_\_\_\_ PHONE #: \_\_\_\_\_

E-MAIL ADDRESS : \_\_\_\_\_

For Assistance, please call (508) 894-5100 to speak with one of our experts.

**For fast, easy ordering, go to [www.freeman.com](http://www.freeman.com)**

Qty	Part #	Description	Online Price	Discount Price	Standard Price	Total
<b>CASUAL SEATING (cont'd)</b>						
_____	81525*	Vibe Cube - Orange Vinyl.....	131.05	144.15	183.45	_____
_____	81520*	Vibe Cube - Pink Vinyl.....	131.05	144.15	183.45	_____
_____	81517*	Vibe Cube - Yellow Vinyl.....	131.05	144.15	183.45	_____
_____	81530*	Vibe Cube - Black Vinyl.....	131.05	144.15	183.45	_____
_____	81531*	Vibe Cube - White Vinyl.....	131.05	144.15	183.45	_____
_____	81532*	Vibe Cube - Steel Blue Vinyl.....	131.05	144.15	183.45	_____
_____	81533*	Vibe Cube - Silver Vinyl.....	131.05	144.15	183.45	_____
_____	81534*	Vibe Cube - Purple Vinyl.....	131.05	144.15	183.45	_____
_____	815151*	Marche Swivel - Gray Fabric.....	203.60	223.95	285.05	_____
_____	815154*	Marche Swivel - Red Fabric.....	203.60	223.95	285.05	_____
_____	815159*	Marche Swivel - Blue Fabric.....	203.60	223.95	285.05	_____
_____	815152*	Marche Swivel - Linen Fabric.....	203.60	223.95	285.05	_____
_____	815157*	Marche Swivel - Meadow Green Fabric.....	203.60	223.95	285.05	_____
_____	815158*	Marche Swivel - Pear Yellow Fabric.....	203.60	223.95	285.05	_____
_____	815156*	Marche Swivel - Plum Fabric.....	203.60	223.95	285.05	_____
_____	815153*	Marche Swivel - Raspberry Fabric.....	203.60	223.95	285.05	_____
_____	815155*	Marche Swivel - Rose Quartz Fabric.....	203.60	223.95	285.05	_____
_____	815150*	Marche Swivel - White Vinyl.....	203.60	223.95	285.05	_____
_____	815160*	Marche Swivel - Orange Fabric.....	203.60	223.95	285.05	_____
_____	81526*	Edge LED Cube - High Density Plastic.....	249.35	274.30	349.10	_____
<b>Banquettes</b>						
_____	8506*	Center Cone w/Electrical Charging Outlet.....	650.00	715.00	910.00	_____
_____	8507*	Quarter Curve Ottoman.....	431.60	474.75	604.25	_____
<b>Beverly Bench Ottomans</b>						
_____	81550*	Black Vinyl.....	409.50	450.45	573.30	_____
_____	81551*	Brown Fabric.....	409.50	450.45	573.30	_____
_____	81552*	Gray Fabric.....	409.50	450.45	573.30	_____
_____	81553*	Linen Fabric.....	409.50	450.45	573.30	_____
_____	81554*	Ocean Blue Fabric.....	409.50	450.45	573.30	_____
_____	81555*	Red Fabric.....	409.50	450.45	573.30	_____
_____	81556*	White Vinyl.....	409.50	450.45	573.30	_____
<b>Accent Chairs</b>						
_____	71089	Black Diamond Side Chair.....	146.90	161.60	205.65	_____
_____	71090	Black Diamond Arm Chair.....	209.40	230.35	293.15	_____
_____	810861*	Laguna Chair - Maple/Chrome.....	126.35	139.00	176.90	_____
_____	210108	Limerick® Chair by Herman Miller.....	116.50	128.15	163.10	_____
_____	8102*	Madrid Chair - Black Vinyl/Chrome.....	963.35	1,059.70	1,348.70	_____
_____	810816*	Madrid Chair - White Vinyl/Chrome.....	963.35	1,059.70	1,348.70	_____
_____	810948*	Meeting Chair - White Vinyl.....	346.70	381.35	485.40	_____
_____	810835*	Meeting Chair - Espresso Vinyl.....	264.65	291.10	370.50	_____
_____	810836*	Meeting Chair - Taupe Microfiber.....	346.70	381.35	485.40	_____
_____	8103*	Key West Tub Chair - Black Fabric.....	485.90	534.50	680.25	_____
_____	810164*	Marina Chair - White Vinyl.....	132.75	146.05	185.85	_____
_____	810160*	Marina Chair - Black Vinyl.....	132.75	146.05	185.85	_____
_____	810161*	Marina Chair - Brown Fabric.....	132.75	146.05	185.85	_____
_____	810162*	Marina Chair - Ocean Blue Fabric.....	132.75	146.05	185.85	_____
_____	810163*	Marina Chair - Red Fabric.....	132.75	146.05	185.85	_____

**FREEMAN furnishings**

Take advantage of the Online price  
by ordering at [www.freeman.com](http://www.freeman.com) before  
SEPTEMBER 27, 2019

NAME OF SHOW: **AFP 2019 / OCTOBER 20-23, 2019**

COMPANY NAME: \_\_\_\_\_ BOOTH #: \_\_\_\_\_ BOOTH SIZE: X

CONTACT NAME : \_\_\_\_\_ PHONE #: \_\_\_\_\_

E-MAIL ADDRESS : \_\_\_\_\_

For Assistance, please call (508) 894-5100 to speak with one of our experts.

**For fast, easy ordering, go to [www.freeman.com](http://www.freeman.com)**

Qty	Part #	Description	Online Price	Discount Price	Standard Price	Total
<b>Occasional Chairs (cont.)</b>						
	810131*	Malba Chair - Gray Molded Plastic.....	90.10	99.10	126.15	
	810130*	Malba Chair - Green Molded Plastic.....	90.10	99.10	126.15	
	810846*	Christopher Chair - White Vinyl/Chrome.....	159.35	175.30	223.10	
	810851*	Zenith Chair - White/Chrome.....	142.75	157.05	199.85	
	810841*	Rustique Chair - Gunmetal.....	159.35	175.30	223.10	
	810837*	Razor Armless Chair - White High Density Plastic....	139.90	153.90	195.85	
	810875*	Swanson Swivel Chair - White Vinyl.....	288.80	317.70	404.30	
	81083*	Blade Chair - Sky Blue.....	72.00	79.20	100.80	
	81082*	Blade Chair - Red.....	72.00	79.20	100.80	
	810810*	Berlin Stack Chair - White & Black Plastic/Chrome...	132.55	145.80	185.55	
	81093*	Lucent Chair - Frosted Acrylic.....	186.75	205.45	261.45	
	810145*	Wentworth Chair - Brown Vinyl.....	303.75	334.15	425.25	
<b>Executive Seating</b>						
	71046	Gray Gaslift Chair With Arms.....	392.40	431.65	549.35	
	71045	Gray Gaslift Chair Without Arms.....	308.80	339.70	432.30	
	810874*	La Brea Swivel Chair - Charcoal Gray Fabric.....	385.05	423.55	539.05	
	81063*	Altura Conference/Guest Chair - Black Fabric/Black Steel.....	388.75	427.65	544.25	
	810844*	Pro Executive High Back Chair - White Vinyl.....	363.20	399.50	508.50	
	810946*	Pro Executive High Back Chair - Black Vinyl.....	363.20	399.50	508.50	
	810945*	Pro Executive Mid Back Chair - White Vinyl.....	320.60	352.65	448.85	
	810944*	Pro Executive Mid Back Chair - Black Vinyl.....	283.30	311.65	396.60	
	810947*	Pro Executive Guest Chair - Black Vinyl.....	332.30	365.55	465.20	
<b>Barstools</b>						
	71088	Black Diamond Stool.....	255.75	281.35	358.05	
	71048	Gray Gaslift Stool with Arms.....	445.65	490.20	623.90	
	71047	Gray Gaslift Stool without Arms.....	392.40	431.65	549.35	
	810860*	Laguna Barstool - Maple/Chrome.....	159.10	175.00	222.75	
	210109	Limerick® Stool by Herman Miller.....	166.20	182.80	232.70	
	810872*	Lift Barstool - Gray Vinyl/Chrome.....	201.55	221.70	282.15	
	810873*	Lift Barstool - Red Vinyl/Chrome.....	201.55	221.70	282.15	
	810871*	Lift Barstool - Black Vinyl/Chrome.....	201.55	221.70	282.15	
	810870*	Lift Barstool - White Vinyl/Chrome.....	201.55	221.70	282.15	
	810951*	Apex Barstool - Black Vinyl.....	210.60	231.65	294.85	
	810952*	Apex Barstool - Blue Ultra Suede.....	210.60	231.65	294.85	
	810953*	Apex Barstool - Red Vinyl.....	210.60	231.65	294.85	
	810954*	Apex Barstool - White Vinyl.....	210.60	231.65	294.85	
	810103*	Banana Barstool - White Vinyl/Chrome.....	231.70	254.85	324.40	
	810104*	Banana Barstool - Black Vinyl/Chrome.....	231.70	254.85	324.40	
	810850*	Zenith Barstool - White/Chrome.....	142.75	157.05	199.85	
	810840*	Zoey Barstool - White Vinyl/Chrome.....	377.10	414.80	527.95	
	810834*	Zoey Barstool - Black Vinyl/Chrome.....	377.10	414.80	527.95	
	810848*	Christopher Barstool - White Vinyl/Chrome.....	191.90	211.10	268.65	
	810202*	Shark Swivel Barstool - White Plastic/Chrome.....	334.10	367.50	467.75	
	810839*	Rustique Barstool - Gunmetal.....	159.35	175.30	223.10	
	810201*	Oslo Barstool - White Plastic/Chrome.....	291.55	320.70	408.15	
	81080*	Blade Barstool - Red.....	146.25	160.90	204.75	
	81081*	Blade Barstool - Sky Blue.....	146.25	160.90	204.75	
	81092*	Lucent Barstool - Frosted Acrylic.....	198.00	217.80	277.20	
	810135*	Task Stool - Black Fabric.....	159.75	175.75	223.65	

NAME OF SHOW: **AFP 2019 / OCTOBER 20-23, 2019**

COMPANY NAME: \_\_\_\_\_ BOOTH #: \_\_\_\_\_ BOOTH SIZE: **X**

CONTACT NAME : \_\_\_\_\_ PHONE #: \_\_\_\_\_

E-MAIL ADDRESS : \_\_\_\_\_

For Assistance, please call (508) 894-5100 to speak with one of our experts.

**For fast, easy ordering, go to [www.freeman.com](http://www.freeman.com)**

Qty	Part #	Description	Online Price	Discount Price	Standard Price	Total
-----	--------	-------------	--------------	----------------	----------------	-------

**Draped Tables & Counters**

<b>Draped Tables</b> - Tables are 24" wide					
<input type="checkbox"/> Black	<input type="checkbox"/> Blue	<input type="checkbox"/> Brown	<input type="checkbox"/> Green	<input type="checkbox"/> Flax	
<input type="checkbox"/> Gold	<input type="checkbox"/> Gray	<input type="checkbox"/> Plum	<input type="checkbox"/> Red	<input type="checkbox"/> White	

_____	124330	Draped Table 3'L x 30"H.....	N/A	N/A	N/A	_____
_____	124430	Draped Table 4'L x 30"H.....	207.75	228.55	290.85	_____
_____	124630	Draped Table 6'L x 30"H.....	259.60	285.55	363.45	_____
_____	124830	Draped Table 8'L x 30"H.....	289.30	318.25	405.00	_____
_____	12404630	4th Side Drape 6'L x 30"H.....	46.80	51.50	65.50	_____
_____	12404830	4th Side Drape 8'L x 30"H.....	46.80	51.50	65.50	_____
_____	124342	Draped Counter 3'L x 42"H.....	N/A	N/A	N/A	_____
_____	124442	Draped Counter 4'L x 42"H.....	262.85	289.15	368.00	_____
_____	124642	Draped Counter 6'L x 42"H.....	312.40	343.65	437.35	_____
_____	124842	Draped Counter 8'L x 42"H.....	343.80	378.20	481.30	_____
_____	12404642	4th Side Drape 6'L x 42"H.....	65.30	71.85	91.40	_____
_____	12404842	4th Side Drape 8'L x 42"H.....	65.30	71.85	91.40	_____

**Undraped Tables & Counters**

_____	125330	Undraped Table 3'L x 30"H.....	N/A	N/A	N/A	_____
_____	125430	Undraped Table 4'L x 30"H.....	87.60	96.35	122.65	_____
_____	125630	Undraped Table 6'L x 30"H.....	107.60	118.35	150.65	_____
_____	125830	Undraped Table 8'L x 30"H.....	135.05	148.55	189.05	_____
_____	125342	Undraped Counter 3'L x 42"H.....	N/A	N/A	N/A	_____
_____	125442	Undraped Counter 4'L x 42"H.....	119.10	131.00	166.75	_____
_____	125642	Undraped Counter 6'L x 42"H.....	138.95	152.85	194.55	_____
_____	125842	Undraped Counter 8'L x 42"H.....	168.10	184.90	235.35	_____

**Table Top Risers - Risers are 8" wide**

_____	1504100	Black 4'L x 7"H Corrugated Riser.....	30.40	33.45	42.55	_____
_____	1504101	White 4'L x 7"H Corrugated Riser.....	30.40	33.45	42.55	_____
_____	1506100	Black 6'L x 7"H Corrugated Riser.....	35.60	39.15	49.85	_____
_____	1506101	White 6'L x 7"H Corrugated Riser.....	35.60	39.15	49.85	_____
_____	1508100	Black 8'L x 7"H Corrugated Riser.....	41.10	45.20	57.55	_____
_____	1508101	White 8'L x 7"H Corrugated Riser.....	41.10	45.20	57.55	_____
_____	1504200	Black 4'L x 14"H Corrugated Riser.....	46.55	51.20	65.15	_____
_____	1504201	White 4'L x 14"H Corrugated Riser.....	46.55	51.20	65.15	_____
_____	1506200	Black 6'L x 14"H Corrugated Riser.....	56.95	62.65	79.75	_____
_____	1506201	White 6'L x 14"H Corrugated Riser.....	56.95	62.65	79.75	_____
_____	1508200	Black 8'L x 14"H Corrugated Riser.....	67.35	74.10	94.30	_____
_____	1508201	White 8'L x 14"H Corrugated Riser.....	67.35	74.10	94.30	_____

**Pedestal Tables - Soho Series**

_____	72069	Black Top Cafe Table - 30"H x 24"W.....	287.20	315.90	402.10	_____
_____	72067	Black Top Cafe Table - 30"H x 36"W.....	287.20	315.90	402.10	_____
_____	72066	Black Top Mini Table - 18"H x 18"W.....	183.75	202.15	257.25	_____
_____	72070	Black Top Bistro Table - 42"H x 24"W.....	287.20	315.90	402.10	_____
_____	72068	Black Top Bistro Table - 42"H x 36"W.....	287.20	315.90	402.10	_____

**Pedestal Tables - Chelsea Series**

_____	72063	Butcher Block Top Cafe Table - 30"H x 30"W.....	229.10	252.00	320.75	_____
_____	72064	Butcher Block Top Cafe Table - 30"H x 36"W.....	229.10	252.00	320.75	_____

**FREEMAN furnishings**

Take advantage of the Online price  
by ordering at [www.freeman.com](http://www.freeman.com) before  
SEPTEMBER 27, 2019

NAME OF SHOW: **AFP 2019 / OCTOBER 20-23, 2019**

COMPANY NAME: \_\_\_\_\_ BOOTH #: \_\_\_\_\_ BOOTH SIZE: **X**  
 CONTACT NAME : \_\_\_\_\_ PHONE #: \_\_\_\_\_  
 E-MAIL ADDRESS : \_\_\_\_\_

For Assistance, please call (508) 894-5100 to speak with one of our experts.

**For fast, easy ordering, go to [www.freeman.com](http://www.freeman.com)**

Qty	Part #	Description	Online Price	Discount Price	Standard Price	Total
<b>Pedestal Tables - Chelsea Series (continued)</b>						
	720163	Butcher Block Top Bistro Table - 42"H x 30"W.....	229.10	252.00	320.75	
	720164	Butcher Block Top Bistro Table - 42"H x 36"W.....	229.10	252.00	320.75	
<b>Pedestal Tables</b>						
	8201208*	Hydraulic Base Cafe Table - Maple.....	325.25	357.80	455.35	
	8201207*	Hydraulic Base Bar Table - Maple.....	341.65	375.80	478.30	
	8201209*	Hydraulic Base Cafe Table - Graphite.....	365.05	401.55	511.05	
	8201211*	Hydraulic Base Bar Table - Graphite.....	374.40	411.85	524.15	
	8201206*	Hydraulic Base Cafe Table - Maple.....	362.70	398.95	507.80	
	8201205*	Hydraulic Base Bar Table - Maple.....	369.70	406.65	517.60	
	820126*	Hydraulic Base Cafe Table - White Laminate.....	379.10	417.00	530.75	
	820125*	Hydraulic Base Bar Table - White Laminate.....	362.70	398.95	507.80	
	820241*	Madison Hydraulic Base Cafe Table - Gray Acajou.	299.50	329.45	419.30	
	820240*	Madison Hydraulic Base Bar Table - Gray Acajou...	299.50	329.45	419.30	
	820265*	Madison Cafe Table - Gray Acajou.....	224.65	247.10	314.50	
	820264*	Madison Bar Table - Gray Acajou.....	245.70	270.25	344.00	
	8201220*	30" Cafe Table Black Base - White Laminate.....	238.70	262.55	334.20	
	8201221*	30" Bar Table Black Base - White Laminate.....	255.05	280.55	357.05	
	8201222*	30" Bar Table Chrome Base - White Laminate.....	367.40	404.15	514.35	
	8201223*	30" Cafe Table Chrome Base - White Laminate.....	367.40	404.15	514.35	
	820920*	30" Bar Table Chrome Hydraulic Base - Red.....	283.15	311.45	396.40	
	820921*	30" Cafe Table Chrome Hydraulic Base - Red.....	283.15	311.45	396.40	
	820922*	30" Bar Table Chrome Hydraulic Base - Graphite.....	283.15	311.45	396.40	
	820923*	30" Cafe Table Chrome Hydraulic Base - Graphite....	283.15	311.45	396.40	
	820924*	30" Bar Table Chrome Hydraulic Base - Silver.....	346.30	380.95	484.80	
	820925*	30" Cafe Table Chrome Hydraulic Base - Silver.....	346.30	380.95	484.80	
	820930*	30" Bar Table w/ Hydraulic Base - Blue.....	272.25	299.50	381.15	
	820931*	30" Bar Table w/ Black Base - Blue.....	216.00	237.60	302.40	
	820932*	30" Bar Table w/ Hydraulic Base - Wood.....	333.00	366.30	466.20	
	820933*	30" Bar Table w/ Black Base - Wood.....	222.75	245.05	311.85	
	820940*	30" Cafe Table w/ Hydraulic Base - Blue.....	272.25	299.50	381.15	
	820941*	30" Cafe Table w/ Black Base - Blue.....	166.50	183.15	233.10	
	820942*	30" Cafe Table w/ Hydraulic Base - Wood.....	333.00	366.30	466.20	
	820943*	30" Cafe Table w/ Black Base - Wood.....	211.50	232.65	296.10	
<b>Accent Tables</b>						
	82015*	Silverado End Table - Tempered Glass/Painted Steel.....	310.25	341.30	434.35	
	82014*	Silverado Cocktail Table - Tempered Glass/Painted Steel.....	330.70	363.75	463.00	
	820252*	Alondra End Table - Glass/Chrome.....	208.25	229.10	291.55	
	820250*	Alondra Cocktail Table - Glass/Chrome.....	287.80	316.60	402.90	
	820253*	Alondra End Table - Wood/Chrome.....	208.25	229.10	291.55	
	820251*	Alondra Cocktail Table - Wood/Chrome.....	287.80	316.60	402.90	
	8201224*	Atomic 36" Round Table - Glass/Chrome.....	320.60	352.65	448.85	
	8201225*	Atomic 42" Round Table - Glass/Chrome.....	320.60	352.65	448.85	
	82028*	Geo End Table - Wood/Black Steel.....	245.70	270.25	344.00	
	82027*	Geo Cocktail Table - Wood/Black Steel.....	250.40	275.45	350.55	
	82035*	Geo End Table - Glass/Chrome.....	280.40	308.45	392.55	

NAME OF SHOW: **AFP 2019 / OCTOBER 20-23, 2019**

COMPANY NAME: \_\_\_\_\_ BOOTH #: \_\_\_\_\_ BOOTH SIZE: **X**

CONTACT NAME : \_\_\_\_\_ PHONE #: \_\_\_\_\_

E-MAIL ADDRESS : \_\_\_\_\_

For Assistance, please call (508) 894-5100 to speak with one of our experts.

**For fast, easy ordering, go to [www.freeman.com](http://www.freeman.com)**

Qty	Part #	Description	Online Price	Discount Price	Standard Price	Total
<b>Accent Tables (continued)</b>						
_____	82034*	Geo Cocktail Table - Glass/Chrome.....	310.25	341.30	434.35	_____
_____	82054*	Sydney End Table - Black Laminate/Brushed Steel..	229.40	252.35	321.15	_____
_____	82055*	Sydney End Table - White Laminate/Brushed Steel..	229.40	252.35	321.15	_____
_____	82052*	Sydney Cocktail Table - Black Laminate/Brushed Steel.....	229.40	252.35	321.15	_____
_____	82053*	Sydney Cocktail Table - White Laminate/Brushed Steel.....	229.40	252.35	321.15	_____
_____	82079*	Sydney End Table - Blue Laminate/Brushed Steel....	229.40	252.35	321.15	_____
_____	82080*	Sydney End Table - Wood Laminate/Brushed Steel..	229.40	252.35	321.15	_____
_____	82077*	Sydney Cocktail Table - Blue Laminate/Brushed Steel.....	229.40	252.35	321.15	_____
_____	82078*	Sydney Cocktail Table - Wood Laminate/Brushed Steel.....	229.40	252.35	321.15	_____
_____	82075*	Regis End Table - Brushed Metal.....	217.60	239.35	304.65	_____
_____	82074*	Regis Bench Table - Brushed Metal.....	306.55	337.20	429.15	_____
_____	820844*	Aura Round Table - White Metal.....	168.85	185.75	236.40	_____
_____	82057*	Edge LED Cube Table-White Plastic/Clear Acrylic....	249.35	274.30	349.10	_____
_____	82043*	Geo Square-Round Table - Glass/Black Steel.....	547.25	602.00	766.15	_____
_____	82044*	Geo Square-Round Table - Glass/Chrome.....	547.25	602.00	766.15	_____
_____	82088*	Oliver End Table - Walnut Finish.....	173.95	191.35	243.55	_____
_____	82087*	Oliver Table - Walnut Finish.....	220.70	242.75	309.00	_____
_____	8201226*	Rustique Square Metal Bar Table - Gray.....	280.80	308.90	393.10	_____
<b>Conference Tables</b>						
_____	82041*	Geo Conference Table - Glass/Black Steel.....	456.05	501.65	638.45	_____
_____	82051*	Geo Conference Table - Glass/Chrome.....	456.05	501.65	638.45	_____
_____	820260*	Madison Conference Table - Gray Acajou.....	383.75	422.15	537.25	_____
_____	820708*	42" Round Conference Table - White Laminate.....	658.75	724.65	922.25	_____
_____	820203*	6' Oval Conference Table - Graphite.....	714.10	785.50	999.75	_____
_____	820261*	Madison 5' Conference Table - Gray Acajou.....	465.65	512.20	651.90	_____
_____	820262*	Madison 8' Conference Table - Gray Acajou.....	929.00	1,021.90	1,300.60	_____
_____	820263*	Madison 10' Conference Table - Gray Acajou.....	929.00	1,021.90	1,300.60	_____
_____	820951*	Ventura Bar Table - Maple w/ Grommets.....	695.00	764.50	973.00	_____
_____	820952*	Ventura Communal Bar Table - Black.....	680.95	749.05	953.35	_____
_____	820953*	Ventura Bar Table - White w/ Grommets.....	695.00	764.50	973.00	_____
_____	820954*	Ventura Communal Bar Table - Maple.....	695.00	764.50	973.00	_____
_____	820956*	Ventura Communal Bar Table - White.....	695.00	764.50	973.00	_____
_____	820963*	Ventura Communal Cafe Table - Maple.....	445.50	490.05	623.70	_____
_____	820960*	Ventura Cafe Table - Maple w/ Grommets.....	668.25	735.10	935.55	_____
_____	820961*	Ventura Cafe Table - White w/ Grommets.....	668.25	735.10	935.55	_____
_____	820966*	Ventura Communal Cafe Table - White.....	445.50	490.05	623.70	_____
_____	820962*	Ventura Communal Cafe Table - Black.....	445.50	490.05	623.70	_____
<b>Office</b>						
_____	84075*	Madison Desk - Gray Acajou.....	554.85	610.35	776.80	_____
_____	84077*	Madison Credenza - Gray Acajou.....	479.70	527.65	671.60	_____
_____	84078*	Madison Bookcase - Gray Acajou.....	409.50	450.45	573.30	_____
<b>Computer Desks/Tables</b>						
_____	820706*	Work Desk - White Laminate.....	412.10	453.30	576.95	_____
_____	820707*	Merlin Table - Gray Laminate.....	522.35	574.60	731.30	_____

NAME OF SHOW: **AFP 2019 / OCTOBER 20-23, 2019**

COMPANY NAME: \_\_\_\_\_ BOOTH #: \_\_\_\_\_ BOOTH SIZE: X

CONTACT NAME : \_\_\_\_\_ PHONE #: \_\_\_\_\_

E-MAIL ADDRESS : \_\_\_\_\_

For Assistance, please call (508) 894-5100 to speak with one of our experts.

**For fast, easy ordering, go to [www.freeman.com](http://www.freeman.com)**

Qty	Part #	Description	Online Price	Discount Price	Standard Price	Total
-----	--------	-------------	--------------	----------------	----------------	-------

**POWERED**

**Powered Seating**

_____	810120*	Naples Chair, Powered - Black Vinyl.....	791.40	870.55	1,107.95	_____
_____	830122*	Naples Loveseat, Powered - Black Vinyl.....	1,054.25	1,159.70	1,475.95	_____
_____	830121*	Naples Sofa, Powered - Black Vinyl.....	1,223.60	1,345.95	1,713.05	_____
_____	81021*	Roma Chair, Powered - White Vinyl.....	791.40	870.55	1,107.95	_____
_____	83017*	Roma Sofa, Powered - White Vinyl.....	1,223.60	1,345.95	1,713.05	_____

**Powered Tables**

_____	820950*	Ventura Communal Bar Table, Powered - Black.....	842.40	926.65	1,179.35	_____
_____	820955*	Ventura Communal Bar Table, Powered - White.....	765.20	841.70	1,071.30	_____
_____	820964*	Ventura Communal Cafe Table, Powered - Black.....	564.75	621.25	790.65	_____
_____	820965*	Ventura Communal Cafe Table, Powered - White.....	564.75	621.25	790.65	_____
_____	84083*	Tech Desk w/ 3 Drawer File Cabinet, Powered - Black Metal.....	563.95	620.35	789.55	_____
_____	84084*	Tech Desk, Powered - Black Metal.....	496.10	545.70	694.55	_____
_____	82076*	Sydney Cocktail Table, Powered - Black.....	383.75	422.15	537.25	_____
_____	82073*	Sydney Cocktail Table, Powered - White.....	383.75	422.15	537.25	_____

**Powered Pedestals**

_____	85060*	Powered Locking Pedestal 36" H, Black.....	575.35	632.90	805.50	_____
_____	85061*	Powered Locking Pedestal 36" H, White.....	575.35	632.90	805.50	_____
_____	85062*	Powered Locking Pedestal 42" H, Black.....	689.20	758.10	964.90	_____
_____	85063*	Powered Locking Pedestal 42" H, White.....	689.20	758.10	964.90	_____
_____	820710*	Wireless Charging Table, Powered.....	447.75	492.55	626.85	_____

**Midtown Counters & Bars**

_____	850103*	Midtown Powered Counter Unlighted - Pewter.....	1,347.75	1,482.55	1,886.85	_____
_____	850102*	Midtown Powered Counter Lighted w/ Plug-In - Pewter.....	1,572.75	1,730.05	2,201.85	_____
_____	850101*	Midtown Bar Unlighted - Pewter.....	1,212.75	1,334.05	1,697.85	_____
_____	850100*	Midtown Bar Lighted w/ Plug-In - Pewter.....	1,437.75	1,581.55	2,012.85	_____

**DISPLAY & ACCESSORIES**

**Product Storage**

_____	84080*	3 Door File Cabinet on Castors - Black .....	173.15	190.45	242.40	_____
_____	74082	File Cabinet w/Lock - Two Drawer - Standard Size...	238.00	261.80	333.20	_____
_____	74081	File Cabinet w/Lock - Four Drawer - Standard Size..	308.80	339.70	432.30	_____
_____	85020*	Posh Shelving w/ Chrome Frame - White.....	512.45	563.70	717.45	_____

**Refrigerator**

_____	75057	Small Refrigerator.....	515.70	567.25	722.00	_____
_____	8503001*	Refrigerator - White.....	960.50	1,056.55	1,344.70	_____

**Lighting**

_____	850707*	Mason Table Lamp - White/Brushed Silver.....	157.20	172.90	220.10	_____
_____	850708*	Mason Floor Lamp - White/Brushed Silver.....	230.90	254.00	323.25	_____

**FREEMAN furnishings**

Take advantage of the Online price by ordering at [www.freeman.com](http://www.freeman.com) before SEPTEMBER 27, 2019

NAME OF SHOW: **AFP 2019 / OCTOBER 20-23, 2019**

COMPANY NAME: \_\_\_\_\_ BOOTH #: \_\_\_\_\_ BOOTH SIZE: X

CONTACT NAME : \_\_\_\_\_ PHONE #: \_\_\_\_\_

E-MAIL ADDRESS : \_\_\_\_\_

For Assistance, please call (508) 894-5100 to speak with one of our experts.

**For fast, easy ordering, go to [www.freeman.com](http://www.freeman.com)**

Qty	Part #	Description	Online Price	Discount Price	Standard Price	Total
<b>DISPLAY &amp; ACCESSORIES</b>						

**Display**

_____	75020	Display Cylinder - Black - Low.....	238.00	261.80	333.20	_____
_____	75021	Display Cylinder - Black - Medium.....	238.00	261.80	333.20	_____
_____	75022	Display Cylinder - Black - High.....	238.00	261.80	333.20	_____
_____	75030	Display Cube - Black - 12" Small.....	277.75	305.55	388.85	_____
_____	75031	Display Cube - Black - 18" Medium.....	297.35	327.10	416.30	_____
_____	75032	Display Cube - Black - 24" Large.....	337.25	371.00	472.15	_____
_____	75079	Orion Computer Kiosk - Black.....	428.85	471.75	600.40	_____
_____	72056	Display Counter - Black.....	278.40	306.25	389.75	_____

**Boxwood Hedges**

_____	85030*	7' Boxwood Hedge.....	639.00	702.90	894.60	_____
_____	85035*	4' Boxwood Hedge.....	342.00	376.20	478.80	_____

**Accessories**

_____	220121	Chrome Stanchion w/ 8' Retractable Belt.....	108.50	119.35	151.90	_____
_____	220118	Chrome Sign Holder.....	205.65	226.20	287.90	_____
_____	750135	Round Literature Rack.....	251.25	276.40	351.75	_____
_____	750136	Flat Literature Rack.....	222.10	244.30	310.95	_____
_____	220109	Chrome Coat Tree.....	74.55	82.00	104.35	_____
_____	220134	Aluminum Easel.....	63.15	69.45	88.40	_____
_____	220110	Chrome Bag Rack.....	163.90	180.30	229.45	_____
_____	10201484	Floor Standing Bulletin Board.....	332.40	365.65	465.35	_____
_____	220106	Corrugated Wastebasket.....	26.50	29.15	37.10	_____

**Special Drape**

- Black    Blue    Brown    Green    Flax  
 Gold    Gray    Plum    Red    White

_____	12103	Special Drape 3'H (per ft.).....	21.75	23.95	30.45	_____
_____	12108	Special Drape 8'H (per ft.).....	30.10	33.10	42.15	_____

TOTAL COST		
_____	+	_____
Sub-Total	6.25% Tax	Total Cost

Taxes: Due to varying taxes across counties and cities for various categories, applicable taxes will be applied to your order accordingly based on the jurisdictions of the show city.

\*Asterisk indicates item is a Freeman Select furnishing

INCLUDE THE FREEMAN METHOD OF PAYMENT FORM WITH YOUR ORDER

NAME OF SHOW: **AFP 2019 / OCTOBER 20-23, 2019**

COMPANY NAME: \_\_\_\_\_ BOOTH #: \_\_\_\_\_

CONTACT NAME: \_\_\_\_\_ PHONE #: \_\_\_\_\_

E-MAIL ADDRESS: \_\_\_\_\_

For Assistance, please call (508) 894-5100 to speak with one of our experts.

For fast, easy ordering, go to [www.freeman.com/store](http://www.freeman.com/store)

## SHOWCASES

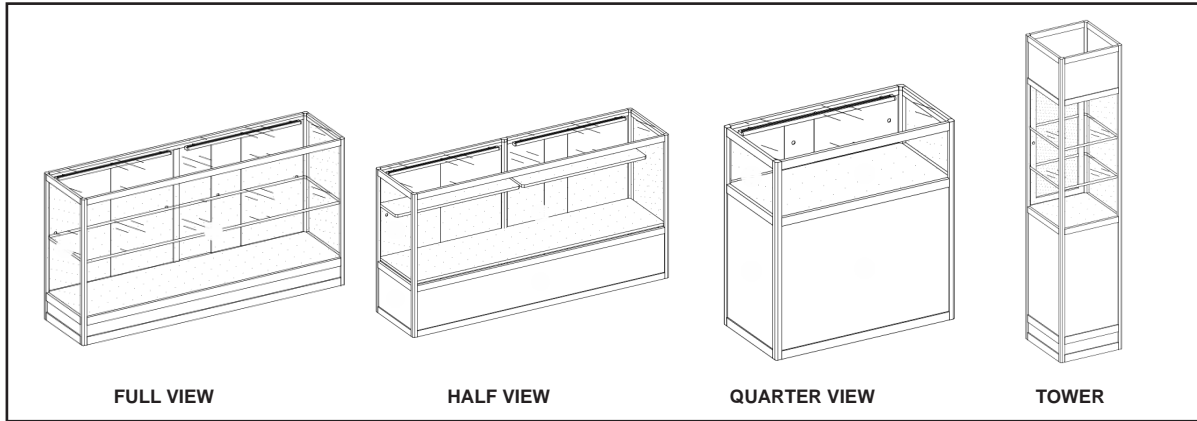

FULL VIEW

HALF VIEW

QUARTER VIEW

TOWER

Want to add graphics? Please contact an Exhibitor Sales Specialist at [NEexhibitorsales@freeman.com](mailto:NEexhibitorsales@freeman.com)

SELECT A SIZE  FULL VIEW  HALF VIEW  QUARTER VIEW

Qty	Description	Discount Price	Standard Price	Total
<b>White PVC, Sliding Doors with lock &amp; includes light (no mirrors)</b>				
_____	Showcase 1m x 36"H .....	\$684.55	\$958.35	_____
_____	Showcase 1m x 42"H .....	\$684.55	\$958.35	_____
_____	Showcase 2m x 36"H .....	\$868.75	\$1,216.25	_____
_____	Showcase 2m x 42"H .....	\$868.75	\$1,216.25	_____
_____	Showcase 1/2m x 1/2m x 8' H Tower .....	\$930.80	\$1,303.10	_____

### QUICK TIPS

- REMEMBER TO MAKE A SELECTION FOR ITEMS WITH CHECKBOXES. OTHERWISE, A SELECTION WILL BE MADE FOR YOU.
- ELECTRICAL SERVICES AND CORD LABOR MUST BE ORDERED SEPERATELY.

### TOTAL COST

Sub-Total \_\_\_\_\_ + Tax (6.25%) \_\_\_\_\_ = TOTAL \_\_\_\_\_

# FROM THE GROUND UP

Engage your audience from the moment they set foot in your exhibit with custom carpets. Our colorfast carpeting boasts a consistent shade every time and the padding exceeds industry standards, ensuring that you'll be floored by the quality. Custom options can be ordered and include borders, patterns and logo applications in both our classic and prestige carpeting lines.

**Sustainability Tip:**

 DARKER COLORED CARPETS SUCH AS BLACK AND GRAY AND THE TWO-TONED CARPET ARE MADE OF 20-25% RECYCLED CONTENT. RENTING CARPET FROM FREEMAN MINIMIZES YOUR SHIPPING FOOTPRINT.

- Colorfast carpet technology guarantees a uniform and professional look throughout the life of your exhibit
- Diverse customization options guarantee the fulfillment of your brand standards
- All carpet and padding is manufactured with recycled material
- Rental prices are all-inclusive so there are never hidden charges for material handling or pickup
- Renting carpet from Freeman minimizes your shipping footprint.



Call customer service at the number listed on the Quick Facts. For fast, easy ordering, go to [freeman.com](http://freeman.com)

## PRESTIGE CARPET

Freeman's prestige carpet combines plush comfort with durable soil and stain resistance, perfect for high-traffic areas. Five popular colors are available in a luxurious 40-ounce weight and all nine designer colors are available in a 28-ounce weight.

Freeman's prestige carpet packages include new 10-foot-wide carpet, delivery, Visqueen covering, installation, carpet tape, carpet removal and all carpet material handling fees. Prestige carpet is one time use. The carpet for your booth will be brand new and recycled at the end of the show. Price includes environmentally friendly disposal of carpet after usage. Foam carpet padding is available for a minimal fee. If you have a large order, please contact us to see if volume discounts may apply.

### Custom Options

Prestige carpets can also be customized to fit your exhibit needs with unique logos, patterns and borders. Call the phone number on the Quick Facts for assistance.



\*Colors available in both 28 oz. and 40 oz.

 **Sustainability Tip:** Prestige carpet is one time use. The carpet for your booth will be brand new and recycled at the end of the show.

## CLASSIC CARPET

### Custom Cut

Freeman classic carpet is available in a range of colors and includes delivery, Visqueen covering, installation, carpet tape, carpet removal and all carpet material handling fees. Foam carpet padding is available for a minimal fee. If you have a large order, please contact us to see if volume discounts may apply.

### Standard Cut

Our classic carpet comes in a variety of sizes. Prices include delivery, installation, carpet tape, carpet removal and all carpet material handling fees. Foam carpet padding and Visqueen covering are available for a minimal fee.

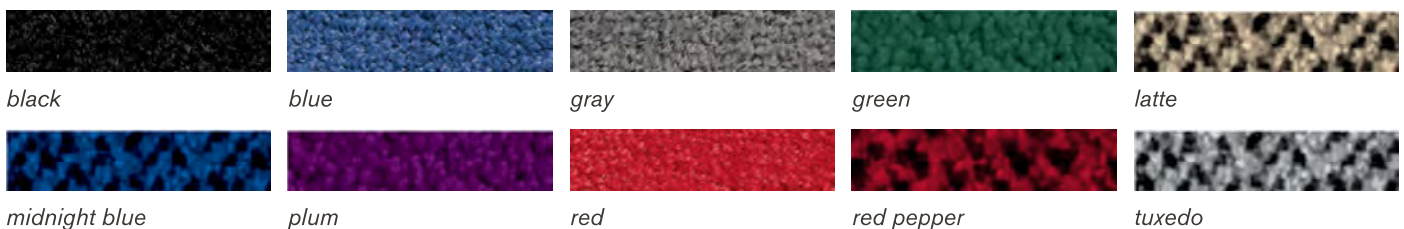

*Actual colors may vary slightly*

**Sustainability Tip:** Freeman Classic carpet is reused a minimum of four times before retired from inventory and recycled. Darker colored carpets such as black and gray, as well as the two-toned carpet are made of 20-25% recycled content.

# FREEMAN

275 Bodwell St  
Avon, MA 02322  
(508) 894-5100 Fax: (469) 621-5608



ONLINE PRICE  
DISCOUNT PRICE  
DEADLINE DATE  
SEPTEMBER 27, 2019

INCLUDE THE FREEMAN METHOD OF PAYMENT FORM WITH YOUR ORDER

NAME OF SHOW: **AFP 2019 / OCTOBER 20-23, 2019**

COMPANY NAME: \_\_\_\_\_ BOOTH #: \_\_\_\_\_ BOOTH SIZE: \_\_\_\_\_ X

CONTACT NAME : \_\_\_\_\_ PHONE #: \_\_\_\_\_

E-MAIL ADDRESS : \_\_\_\_\_

For Assistance, please call (508) 894-5100 to speak with one of our experts.

- Orders received after the deadline or without payment will be charged the Standard price.
- All utility lines must be installed before carpet installation. Utilities should be ordered in advance.
- Pricing includes delivery, material handling, installation and removal.

All carpets, padding and plastic covering contain recycled content and are recyclable.

For fast, easy ordering, go to [www.freeman.com](http://www.freeman.com)

## 10' CLASSIC CARPET , PADDING & PLASTIC COVERING

CHOOSE YOUR CARPET COLOR:

- Black  Blue  Gray  Green  Latte  Midnight Blue  Plum  Red  Red Pepper  Tuxedo

Qty	Description	Online Price	Discount Price	Standard Price	Total
_____	10' x 10' Classic Carpet .....	\$ 400.40	\$ 440.45	\$ 560.55	_____
_____	10' x 20' Classic Carpet .....	\$ 800.80	\$ 880.90	\$ 1,121.10	_____
_____	10' x 30' Classic Carpet .....	\$ 1,201.20	\$ 1,321.30	\$ 1,681.70	_____
_____	10' x 40' Classic Carpet .....	\$ 1,601.60	\$ 1,761.75	\$ 2,242.25	_____
_____	10' x 10' Carpet Padding - Single Layer.....	\$ 192.40	\$ 211.65	\$ 269.35	_____
_____	10' x 20' Carpet Padding - Single Layer.....	\$ 384.80	\$ 423.30	\$ 538.70	_____
_____	10' x 30' Carpet Padding - Single Layer.....	\$ 577.20	\$ 634.90	\$ 808.10	_____
_____	10' x 40' Carpet Padding - Single Layer.....	\$ 769.60	\$ 846.55	\$ 1,077.45	_____
_____	10' x 10' Carpet Padding - Double Layer.....	\$ 384.80	\$ 423.30	\$ 538.70	_____
_____	10' x 20' Carpet Padding - Double Layer.....	\$ 769.60	\$ 846.55	\$ 1,077.45	_____
_____	10' x 30' Carpet Padding - Double Layer.....	\$ 1,154.40	\$ 1,269.85	\$ 1,616.15	_____
_____	10' x 40' Carpet Padding - Double Layer.....	\$ 1,539.20	\$ 1,693.10	\$ 2,154.90	_____
_____	Plastic Covering (price per sq. ft.).....	\$ 1.50	\$ 1.65	\$ 2.10	_____

## 9' CLASSIC CARPET , PADDING & PLASTIC COVERING

CHOOSE YOUR CARPET COLOR:

- Black  Blue  Gray  Green  Latte  Midnight Blue  Plum  Red  Red Pepper  Tuxedo

Qty	Description	Online Price	Discount Price	Standard Price	Total
_____	9' x 10' Classic Carpet .....	\$ 328.90	\$ 361.80	\$ 460.45	_____
_____	9' x 20' Classic Carpet .....	\$ 657.80	\$ 723.60	\$ 920.90	_____
_____	9' x 30' Classic Carpet .....	\$ 986.70	\$ 1,085.35	\$ 1,381.40	_____
_____	9' x 40' Classic Carpet .....	\$ 1,315.60	\$ 1,447.15	\$ 1,841.85	_____
_____	9' x 10' Carpet Padding - Single Layer.....	\$ 173.15	\$ 190.45	\$ 242.40	_____
_____	9' x 20' Carpet Padding - Single Layer.....	\$ 346.30	\$ 380.95	\$ 484.80	_____
_____	9' x 30' Carpet Padding - Single Layer.....	\$ 519.45	\$ 571.40	\$ 727.25	_____
_____	9' x 40' Carpet Padding - Single Layer.....	\$ 692.60	\$ 761.85	\$ 969.65	_____
_____	9' x 10' Carpet Padding - Double Layer.....	\$ 346.30	\$ 380.95	\$ 484.80	_____
_____	9' x 20' Carpet Padding - Double Layer.....	\$ 692.60	\$ 761.85	\$ 969.65	_____
_____	9' x 30' Carpet Padding - Double Layer.....	\$ 1,038.90	\$ 1,142.80	\$ 1,454.45	_____
_____	9' x 40' Carpet Padding - Double Layer.....	\$ 1,385.20	\$ 1,523.70	\$ 1,939.30	_____
_____	Plastic Covering (price per sq. ft.).....	\$ 1.50	\$ 1.65	\$ 2.10	_____

\*\*9' carpet is laid toward the front edge, leaving 1' at the back of the booth for access to utility ports.\*\*

TOTAL COST		
Sub- Total	+	6.25% Tax
	=	Total Cost

FREEMAN standard size carpet

Take advantage of the Online price by ordering at [www.freeman.com](http://www.freeman.com) before SEPTEMBER 27, 2019

# FREEMAN

275 Bodwell St  
Avon, MA 02322  
(508) 894-5100 Fax: (469) 621-5608



ONLINE PRICE  
DISCOUNT PRICE  
DEADLINE DATE  
SEPTEMBER 27, 2019

INCLUDE THE FREEMAN METHOD OF  
PAYMENT FORM WITH YOUR ORDER

NAME OF SHOW: **AFP 2019 / OCTOBER 20-23, 2019**

COMPANY NAME: \_\_\_\_\_ BOOTH #: \_\_\_\_\_ BOOTH SIZE: \_\_\_\_\_ X

CONTACT NAME: \_\_\_\_\_ PHONE #: \_\_\_\_\_

E-MAIL ADDRESS: \_\_\_\_\_

For Assistance, please call (508) 894-5100 to speak with one of our experts.

- Guaranteed new, high-quality carpet.
- Orders received after the deadline or without payment will be charged the Standard price and are subject to availability.
- Prestige and Custom Cut Classic Carpet are subject to a 100% cancellation charge.
- All utility lines must be installed before carpet installation. Utilities should be ordered in advance.

All carpets, padding and plastic covering contain recycled content and are recyclable.

For fast, easy ordering, go to [www.freeman.com](http://www.freeman.com)

**CUSTOM CUT CLASSIC CARPET - includes plastic covering, delivery, material handling, installation and removal**

- Order Custom Cut Classic Carpeting by the sq. ft. if your size is not listed on the standard size order form.

Sample: Booth Size: 10 x 25 = 250 sq. ft. @ \$ **4.20**

**CHOOSE YOUR CARPET COLOR - 16 oz. Carpet:**

- Black  Blue  Gray  Green  Latte  Midnight Blue  Plum  Red  Red Pepper  Tuxedo

**16 oz. Carpet Rental** - Price per sq. ft (100 sq. ft. minimum)

Per sq. ft.	Booth Size: _____ x _____ = _____ sq. ft. @	Online Price	Discount Price	Standard Price	Total
		\$ <b>4.20</b>	\$ <b>4.60</b>	\$ <b>5.90</b>	_____

**PRESTIGE CARPET - includes plastic covering, delivery, material handling, installation and removal**

**CHOOSE YOUR CARPET COLOR - 28 oz. Carpet:**

- Black  Cardinal  Charcoal  Cream  Gray Pearl  Navy  Toast  Wedgewood  White

**28 oz. Carpet Rental** - Price per sq. ft. (100 sq. ft. minimum)

	Booth Size: _____ x _____ = _____ sq. ft. @	Online Price	Discount Price	Standard Price	Total
1 - 700 sq. ft.		\$ <b>5.95</b>	\$ <b>6.55</b>	\$ <b>8.35</b>	_____
Over 700 sq. ft.		\$ <b>4.60</b>	\$ <b>5.05</b>	\$ <b>6.45</b>	_____

**CHOOSE YOUR CARPET COLOR - 40 oz. Carpet:**

- Black  Charcoal  Gray Pearl  Navy  White

**40 oz. Carpet Rental** - Price per sq. ft. (100 sq. ft. minimum)

	Booth Size: _____ x _____ = _____ sq. ft. @	Online Price	Discount Price	Standard Price	Total
1 - 700 sq. ft.		\$ <b>6.50</b>	\$ <b>7.15</b>	\$ <b>9.10</b>	_____
Over 700 sq. ft.		\$ <b>5.95</b>	\$ <b>6.55</b>	\$ <b>8.35</b>	_____

**CARPET PADDING - includes delivery, material handling, installation and removal**

- Order Carpet Padding by the sq. ft. if your size is not listed on the standard size order form.

Sample: Booth Size: 10 x 25 = 250 sq. ft. @ \$ **2.05**

Qty	Description	Price per sq. ft. (90 sq. ft. minimum)	Online Price	Discount Price	Standard Price	Total
_____	Carpet Padding -1/2" (90 - 700 sq. ft.)		\$ <b>2.05</b>	\$ <b>2.25</b>	\$ <b>2.85</b>	_____
_____	Carpet Padding-1/2" (Over 700 sq. ft.)		\$ <b>1.60</b>	\$ <b>1.75</b>	\$ <b>2.25</b>	_____
_____	Double Carpet Padding - 1/2" (90 - 700 sq. ft.)		\$ <b>4.10</b>	\$ <b>4.50</b>	\$ <b>5.75</b>	_____
_____	Double Carpet Padding -1/2" (Over 700 sq. ft.)		\$ <b>3.20</b>	\$ <b>3.50</b>	\$ <b>4.50</b>	_____

TOTAL COST		
_____	+	_____
Sub- Total		6.25% Tax
	=	_____
		Total Cost

FREEMAN cut to size carpet

Take advantage of the Online price by ordering at [www.freeman.com](http://www.freeman.com) before SEPTEMBER 27, 2019

# FREEMAN

275 Bodwell St  
 Avon, MA 02322  
 (508) 894-5100 Fax: (469) 621-5608



INCLUDE THE FREEMAN METHOD OF PAYMENT FORM WITH YOUR ORDER

NAME OF SHOW: **AFP 2019 / OCTOBER 20-23, 2019**

COMPANY NAME: \_\_\_\_\_ BOOTH #: \_\_\_\_\_ BOOTH SIZE: \_\_\_\_\_ X

CONTACT NAME : \_\_\_\_\_ PHONE #: \_\_\_\_\_

E-MAIL ADDRESS : \_\_\_\_\_

For Assistance, please call (508) 894-5100 to speak with one of our experts.

For fast, easy ordering, go to [www.freeman.com](http://www.freeman.com)

## CLEANING SERVICES

- **Cleaning is an exclusive service. This includes all floor services and trash removal.**
- Prices are based on total square footage of booth regardless of area to be cleaned.
- **Show Site Prices will apply to all cleaning orders placed at show site.**

### VACUUMING (per sq. ft. - 100 sq. ft. minimum)

Qty (sq. ft.)	Part #	Description	Advance Price	Show Site Price	Total
_____	610100	Booth Vacuuming - One Time .....	.95	1.35	_____
_____	610200	Booth Vacuuming - 2 Days .....	N/A	N/A	_____
_____	610300	Booth Vacuuming - 3 Days .....	2.85	4.00	_____
_____	610400	Booth Vacuuming - 4 Days .....	N/A	N/A	_____

• Includes emptying of your booth's wastebasket(s) at the time of vacuuming.

### SHAMPOOING (per sq ft - 100 sq ft minimum)

Qty (sq. ft.)	Part #	Description	Advance Price	Show Site Price	Total
_____	630100	Shampoo Carpet - One Time .....	1.40	1.95	_____
_____	630200	Shampoo Carpet - 2 Days .....	2.80	3.90	_____
_____	630300	Shampoo Carpet - 3 Days .....	4.20	5.90	_____

### PORTER SERVICE (per day)

Qty (# days)	Part #	Description	Advance Price	Show Site Price	Total
_____	620500	Exhibit Area / Under 500 sq.ft. ....	201.75	282.45	_____
_____	6201500	Exhibit Area / 501 - 1,500 sq. ft. ....	248.55	347.95	_____
_____	6202500	Exhibit Area / 1,501 - 2,500 sq. ft. ....	296.40	414.95	_____
_____	6203500	Exhibit Area / Over 2,500 sq.ft.....			Call for Quote

### TOTAL COST

_____	+	_____	=	_____
Sub-Total		N/A %Tax		Total Cost

# FIT TO PRINT

SmartFabric® is a triple-layered fabric made of 100 percent polyester that's ideal for printed graphics. It's an extremely versatile all-in-one fabric and has been treated to meet NFPA 701 small-scale flammability standards. This lightweight material provides an easy way to make a big impact and has a small shipping footprint to reduce your shipping cost and carbon emissions.



\* Client to provide print-ready artwork, or Freeman can design artwork for an additional fee.

## SMARTFABRIC® RENTAL EXHIBITS



**10 x 10 ft. unit**

**GRAPHIC SIZE**

116"W 92.5"H



**10 x 20 ft. unit**

**GRAPHIC SIZE**

233.5"W 92.5"H

### RENTAL EXHIBITS INCLUDE:

- Custom Fabric Graphic\* with zippered carrying case (fabric graphic purchased to keep)
- Rental Frame, a 100% recyclable structure
- 9' x 10' or 9' x 20' Classic Carpet (color selections on page 3)
- Exhibit Installation & Dismantle
- Exhibit Material Handling
- Nightly Vacuuming
- 3 Arm Lights per 10' Booth
- 6 Arm Lights per 20' Booth
- Power for lights only

## FRAME ONLY UNIT

If you rented a SmartFabric booth previously, you own the graphic. For subsequent shows, all you need to do is rent the frame. We will install your fabric graphic over the frame.\*\*

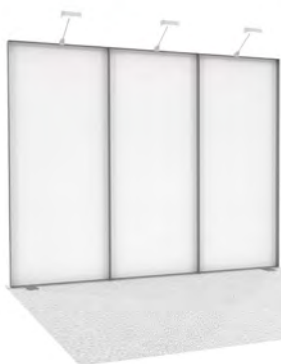

**10 x 10 ft. frame**

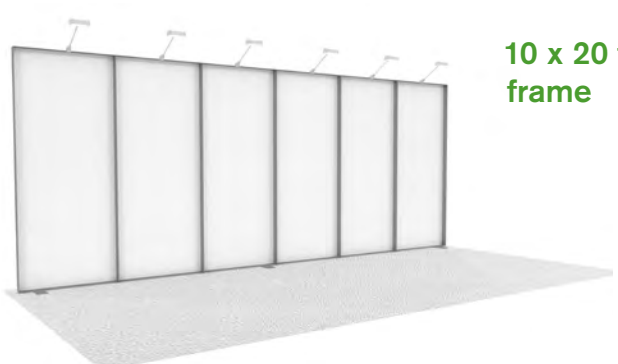

**10 x 20 ft. frame**

### RENTAL EXHIBITS INCLUDE:

- Rental Frame
- 9' x 10' or 9' x 20' Classic Carpet (color selections on page 3)
- Exhibit Installation & Dismantle
- Exhibit Material Handling
- Nightly Vacuuming
- 3 Arm Lights per 10' Booth
- 6 Arm Lights per 20' Booth
- Power for lights only

\*Client to provide print-ready artwork, or Freeman can design artwork for an additional fee. \*\*Only Freeman SmartFabric will be installed on the frame.

## CLASSIC CARPET

Freeman Classic carpet is reused a minimum of four times before being retired from inventory and recycled. Darker-colored carpets such as black and gray, as well as two-toned carpets, are made of 20-25 percent recycled content.

**9' x 10' or 9' x 20' (16 oz.)** – Color Options Included with Rental Package Options

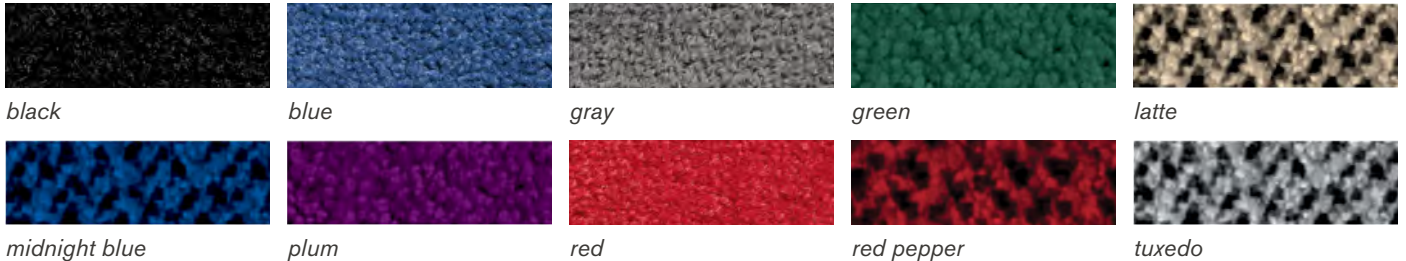

9' carpet is laid toward the front edge, leaving 1' at the back of the booth for utility port access. Actual colors may vary slightly.

## PRESTIGE CARPET

Prestige carpet is for one time use. The carpet for your booth will be brand new and recycled at the end of the show. Renting carpet from Freeman minimizes your shipping footprint.

**(28 oz.)** – Available Upgrade Color Options

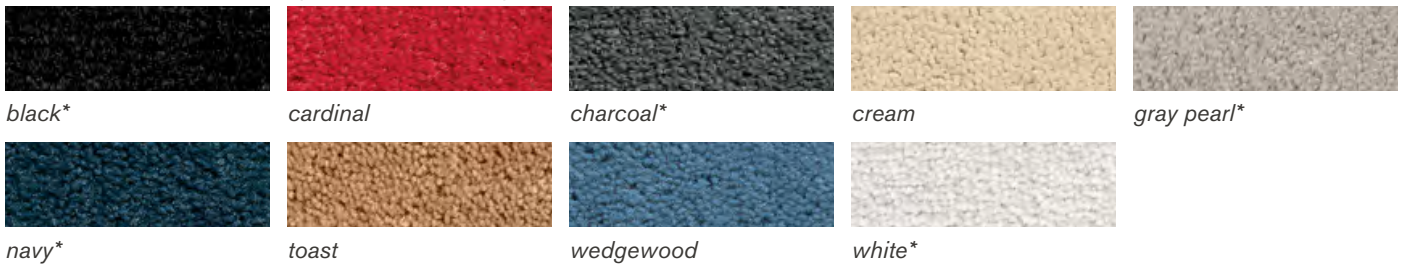

\*Colors available in both 28 oz. and 40 oz. Actual colors may vary slightly.

## OPTIONAL ACCESSORIES

### SMARTFABRIC® ZIPPERED CARRYING CASE

20"W | 8"H | 16"D

One SmartFabric zipper bag is included with purchase.



### CLEAR ACRYLIC SHELF

36"W | .25"H | 12"D

(holds up to 15 lbs each)



## CUSTOM GRAPHICS

An exhibitor sales specialist will contact you to review the process for providing your own graphic files or options for using our graphic design services to design your back wall.

## FREEMAN SUSTAINABILITY FOCUS

 This solution is a clean footprint booth. This rental unit includes a 100 percent recyclable aluminum frame. All flooring, lighting, furniture, and booth structure will go back into inventory to be reused or recycled.

# FREEMAN

275 Bodwell St  
Avon, MA 02322  
(508) 894-5100 Fax: (469) 621-5608



DISCOUNT PRICE  
DEADLINE DATE  
SEPTEMBER 27, 2019

INCLUDE THE FREEMAN METHOD OF PAYMENT FORM WITH YOUR ORDER

NAME OF SHOW: **AFP 2019 / OCTOBER 20-23, 2019**

COMPANY NAME: \_\_\_\_\_ BOOTH #: \_\_\_\_\_ BOOTH SIZE: X

CONTACT NAME : \_\_\_\_\_ PHONE #: \_\_\_\_\_

E-MAIL ADDRESS : \_\_\_\_\_

For Assistance, please call (508) 894-5100 to speak with one of our experts.

For fast, easy ordering, go to [www.freeman.com](http://www.freeman.com)

## SMARTFABRIC EXHIBIT

SmartFabric Exhibits provide a custom printed fabric graphic to keep and reuse on future events.



### SmartFabric Rental Exhibit Includes:

- 116.5" X 92.5" Custom Fabric Graphic (Purchased item to keep)
- Carrying Case for Graphic (To carry the purchased fabric graphic)
- Classic Carpet 9' X 10' or 9' X 20' (Select color below)
- Installation & Dismantle of Exhibit
- Material Handling of Exhibit
- Nightly Vacuuming
- 3-Arm Lights (per 10 ft.)
- Power for LIGHTS only

Classic Carpet:  Black  Blue  Gray  Green  Latte  
 Midnight Blue  Plum  Red  Red Pepper  Tuxedo

Qty	Description	Discount	Standard	Total
_____	10' x 10' SmartFabric Exhibit.....	\$ 2,155.00	\$ 3,017.00	_____
_____	10' x 20' SmartFabric Exhibit.....	\$ 4,155.00	\$ 5,817.00	_____

## CUSTOM GRAPHICS

A Freeman Exhibitor Sales Specialist will be contacting you to review the process for providing graphic files and helpful tips that will ensure a successful graphic print.

## FRAME ONLY UNIT

The SmartFabric frame only unit is for exhibitors who have previously rented the SmartFabric exhibit (above) and have the fabric graphic ready for reuse. If you need a new graphic made, please select the SmartFabric Rental Exhibit (above). No fabric graphics will be printed without the rental unit.



### Frame Only Unit Includes:

- Classic Carpet 9' X 10' or 9' X 20' (Select color below)
- Installation & Dismantle of Exhibit
- Material Handling of Exhibit
- Nightly Vacuuming
- 3-Arm Lights (per 10 ft.)
- Power for LIGHTS only

Classic Carpet:  Black  Blue  Gray  Green  Latte  
 Midnight Blue  Plum  Red  Red Pepper  Tuxedo

Qty	Description	Discount	Standard	Total
_____	10' x 10' Frame Only Unit.....	\$ 1,410.00	\$ 1,974.00	_____
_____	10' x 20' Frame Only Unit.....	\$ 2,350.00	\$ 3,290.00	_____

## ACCESSORIES

Qty	Description	Discount	Standard	Total
_____	SmartFabric Arm Light .....	\$ 65.00	\$ 91.00	_____
_____	SmartFabric Acrylic Shelf (supports up to 15 lbs).....	\$ 150.00	\$ 210.00	_____
_____	SmartFabric Carrying Case (purchase).....	\$ 20.00	\$ 28.00	_____

## QUICK TIPS

• Orders received after the deadline or without payment will be charged the Standard price and are subject to availability. All graphics are subject to a 100% cancellation charge once production begins.

☑ The product offered has recyclable content or has eco-friendly attributes and is 100% recyclable according to manufacturer's specifications.

\*\*9' carpet is laid toward the front edge, leaving 1' at the back of the booth for access to utility ports.\*\*

TOTAL COST		
_____	+	_____ = _____
Sub-Total		6.25 % Tax Total Cost

# RENTAL EXHIBITS THAT IMPRESS

When it comes to designing your exhibit, effective solutions don't require expensive investments. Take the stress out of your upcoming show with a rental exhibit from Freeman. With quality rental options that meet your budget requirements, we'll have you exhibit ready at a moment's notice, without the hassle of ownership.

**PACKAGE 1**



10 X 20



10 X 10

**PACKAGE 1 UPGRADE OPTIONS**

With Graphics and Cabinet

10 X 10



# FREEMAN

## PACKAGE 2



10 X 20



10 X 10

## PACKAGE 3



10 X 20



10 X 10

## PACKAGE 4



10 X 20



10 X 10

## PACKAGE 2 UPGRADE OPTIONS

With Graphics and Cabinet

10 X 10



## PACKAGE 3 UPGRADE OPTIONS

With Graphics and Cabinet

10 X 10



## PACKAGE 4 UPGRADE OPTIONS

With Graphics and Cabinet

10 X 10



# FREEMAN

## PACKAGE 5



10 X 20



10 X 10

## PACKAGE 6



10 X 20



10 X 10

## PACKAGE 5 UPGRADE OPTIONS

With Graphics and Cabinet

10 X 10



## PACKAGE 6 UPGRADE OPTIONS

With Graphics and Cabinet

10 X 10



# FREEMAN

There are upgrade options available that allow you to change the panels to slatwall, add shelves, change the metal color and add cabinets as a storage option with the dual purpose of a reception counter.



10 X 10

**SLATWALL**



10 X 10

**COLORED PANELS**



10 X 10

**SHELVES**



10 X 10

**BLACK METAL**



**CABINETS**

## Booth Panel Options – Color Options Included with Rental Package



## Classic Carpet (16 oz.) – Color Options Included with Rental Package Options. Darker colored Classic carpet is made of 25-50% recycled content.



9' carpet is laid toward the front edge, leaving 1' at the back of the booth for utility port access. Actual colors may vary slightly.

## Prestige Carpet (28 oz.) – Available Upgrade Color Options



\*Colors available in both 28 oz. and 40 oz. Actual colors may vary slightly.

## Rental Exhibits Include:

- 9x10 or 9x20 Classic Carpet
- Exhibit Installation & Dismantle
- Exhibit Material Handling
- Nightly Vacuuming
- 2-arm lights per 10' Booth
- Power (500 watts) for LIGHTS only (and Labor to hang lights)

## questions?

All packages can be customized or modified to fit your specific needs. To speak with an Exhibitor Sales Specialist, call the number listed on the Quick Facts.



## “CLEAN FOOTPRINT” MATERIALS

When you select “Clean Footprint” materials for your booth we will use only materials that can be reused or recycled. All flooring, lighting, furniture, and booth structure will go back into inventory to be reused again. Your personalized graphic panels used in the booth will be printed on reusable and 100% recyclable substrate such as Freeman honeycomb, conerd board and reboard. Using a Freeman rental unit includes 100% recyclable aluminum in the structure and virtually eliminates your shipping footprint and carbon emissions.

# FREEMAN

275 Bodwell St  
Avon, MA 02322  
(508) 894-5100 Fax: (469) 621-5608



DISCOUNT PRICE  
DEADLINE DATE  
SEPTEMBER 27, 2019

INCLUDE THE FREEMAN METHOD OF  
PAYMENT FORM WITH YOUR ORDER

NAME OF SHOW: **AFP 2019 / OCTOBER 20-23, 2019**

COMPANY NAME: \_\_\_\_\_ BOOTH #: \_\_\_\_\_ BOOTH SIZE: \_\_\_\_\_ X

CONTACT NAME : \_\_\_\_\_ PHONE #: \_\_\_\_\_

E-MAIL ADDRESS : \_\_\_\_\_

For Assistance, please call **(508) 894-5100** to speak with one of our experts.

For fast, easy ordering, go to [www.freeman.com](http://www.freeman.com)

**All Exhibits Include:** installation & dismantle of exhibit, material handling of exhibit, 9' x 10' or 9' x 20' classic carpet with nightly vacuuming, 2 arm lights (per 10' unit), power (500 watts) for lights ONLY and labor to hang arm lights.

To place your order, please check the appropriate box and complete the remaining selections at the bottom of the form.

## RENTAL EXHIBITS

		Discount Price	Standard Price		Discount Price	Standard Price	
Package 1	<input type="checkbox"/> 10' x 10'	3,474.40	4,864.15	<input type="checkbox"/> 10' x 20'	5,316.80	7,443.50	_____
Package 2	<input type="checkbox"/> 10' x 10'	2,154.00	3,015.60	<input type="checkbox"/> 10' x 20'	3,991.85	5,588.60	_____
Package 3	<input type="checkbox"/> 10' x 10'	4,023.70	5,633.20	<input type="checkbox"/> 10' x 20'	4,721.10	6,609.55	_____
Package 4	<input type="checkbox"/> 10' x 10'	2,921.65	4,090.30	<input type="checkbox"/> 10' x 20'	5,987.70	8,382.80	_____
Package 5	<input type="checkbox"/> 10' x 10'	3,063.00	4,288.20	<input type="checkbox"/> 10' x 20'	6,125.85	8,576.20	_____
Package 6	<input type="checkbox"/> 10' x 10'	3,193.40	4,470.75	<input type="checkbox"/> 10' x 20'	5,035.85	7,050.20	_____

## CHOOSE YOUR PANEL

- Black Fabric     Blue Fabric     Gray Fabric     White Hardwall     White Perfboard

## CARPET

Our Classic Carpet and nightly vacuuming are included in the price of your Rental Exhibit. The following colors are available:

Check color choice

- Black     Blue     Gray     Green     Latte  
 Midnight Blue     Plum     Red     Red Pepper     Tuxedo

You may want to add padding or upgrade your carpet to one of our 15 designer colors in our PRESTIGE carpet line. Now available in **28 oz.** and **40 oz.** weight. Refer to our enclosed Carpet order form for color selections and pricing.

## LIGHTING

Each Rental Exhibit includes 2 Arm Lights (per 10' unit).

Note: Power and labor to hang the lights are included in our standard rental exhibit package price. Power consumption not to exceed 500 Watts.

Additional power must be ordered separately.

## HEADER IDENTIFICATION SIGN

Indicate which color lettering you would like. We have a wide variety of standard colors available:

- Black     Blue     Brown     Burgundy     PMS Color \_\_\_\_\_  
 Red     Teal     White     Green     Font Type \_\_\_\_\_

Indicate exactly how you want your company name to appear:

\*Unless font type is indicated, Helvetica will be used.

## ENHANCE YOUR EXHIBIT

Enhance your exhibit and have an Exhibitor Sales Specialist contact you for pricing by checking any of the following boxes:

- Slatwall & Shelves     Cabinets & Counters     Specialty Colored Metal     Recyclable Graphics  
 Colored Panels     Creating a Custom Exhibit     Graphics & Custom Logo     White Eco-Board

The product offered has recyclable content or has eco-friendly attributes and is 100% recyclable according to manufacturer's specifications.

TOTAL COST		
_____	+	_____ = _____
Sub-Total		6.25 % Tax    Total Cost

# FREEMAN

275 Bodwell St  
Avon, MA 02322  
(508) 894-5100 Fax: (469) 621-5608



DISCOUNT PRICE  
DEADLINE DATE  
SEPTEMBER 27, 2019

INCLUDE THE FREEMAN METHOD OF  
PAYMENT FORM WITH YOUR ORDER

NAME OF SHOW: **AFP 2019 / OCTOBER 20-23, 2019**

COMPANY NAME: \_\_\_\_\_ BOOTH #: \_\_\_\_\_ BOOTH SIZE: \_\_\_\_\_ X

CONTACT NAME : \_\_\_\_\_ PHONE #: \_\_\_\_\_

E-MAIL ADDRESS : \_\_\_\_\_

For Assistance, please call (508) 894-5100 to speak with one of our experts.

For fast, easy ordering, go to [www.freeman.com](http://www.freeman.com)  
**ACCESSORIES FOR RENTAL UNITS**

<p><b>LIGHTS (use only on rentals)</b></p>	<p><b>SHELVES (use only on rentals)</b></p>	<p><b>CABINETS</b></p>
<p><b>GONDOLAS</b></p>	<p><b>RADIUS CABINET (does not have doors)</b></p>	<p><b>LITERATURE POCKETS</b></p>

Qty	Part #	Description	Discount Price	Standard Price	Total
<b>LIGHT FIXTURES</b>					
<b>(electrical service &amp; labor to install lights not included)</b>					
___	172512	Arm Light .....	82.00	114.80	_____
___	172514	4' Tracklight (3 lights)	323.45	452.85	_____
___	17252	Halogen Light .....	N/A	N/A	_____

<b>CABINETS &amp; LOCKS</b>					
<b>Cabinets</b>					
<input type="checkbox"/> Black Fabric <input type="checkbox"/> Blue Fabric <input type="checkbox"/> Gray Fabric <input type="checkbox"/> White PVC					
___	17305	1M x ½M x 36" High.....	438.90	614.45	_____
___	17306	1M x ½M x 42" High.....	438.90	614.45	_____
___	17308	2M x ½M x 36" High.....	640.65	896.90	_____
___	17309	2M x ½M x 42" High.....	640.65	896.90	_____
___	173010	1M Radius x ½M x 36" High.	684.55	958.35	_____
___	173011	1M Radius x ½M x 42" High..	684.55	958.35	_____
(Radius Cabinets do not have doors)					
___	17301	Cabinet Lock .....	18.40	25.75	_____
Inside Shelves Available ..... Quoted on Request					

Qty	Part #	Description	Discount Price	Standard Price	Total
<b>GONDOLAS</b>					
<b>Gondolas</b>					
<input type="checkbox"/> Blue Fabric <input type="checkbox"/> Gray Fabric <input type="checkbox"/> Perboard <input type="checkbox"/> White PVC					
___	174541	Single Sided 1M x 4' High...	342.25	479.15	_____
___	174542	Double Sided 1M x 4' High..	456.40	638.95	_____
___	174581	Single Sided 1M x 8' High...	513.50	718.90	_____
___	174582	Double Sided 1M x 8' High..	684.55	958.35	_____

<b>SHELVES</b>					
___	17201	1M Straight (37" x12") .....	82.00	114.80	_____
___	17206	1M Angled (37" x 12") .....	82.00	114.80	_____

<b>LITERATURE POCKETS</b>					
___	174015	For 8½ x 11 Literature .....	34.75	48.65	_____

<b>TOTAL COST</b>					
_____	Sub-Total	+	6.25% Tax	=	_____
			Total Cost		

Don't see what you need?  
Please call Exhibitor Sales at (508) 894-5100.

*\* Remember to make a selection for items with checkboxes. Otherwise, a selection will be made for you.*

# FLEXING TO FIT YOUR NEEDS

---

TotalFlex® provides the ability to configure exhibits to fit your space, budget and vision from show to show. Available for rent or for purchase, this pop-up display is versatile, lightweight and durable, and setup can be completed without tools in only a few minutes.



Call customer service at the number listed on the Quick Facts. For fast, easy ordering, go to [www.freeman.com](http://www.freeman.com)

The TotalFlex® solution is the most versatile exhibit option available:

- Floor unit cases easily convert into a podium.
- Velcro-compatible fabric panels available in a wide selection of colors.
- Compatible with shelves, lights and other innovative trade show accessories.
- Available in a variety of sizes for rent or purchase, including a tabletop version (shown on front).
- Freeman offers full graphic and logo design solutions.\*
- All TotalFlex® rental units include installation & dismantling of display system, material handling, 9'x10' or 9'x20' Classic Carpet with nightly vacuuming, 200-watt halogen lights (1 light for the table-top unit, 2 lights per 8x10 unit) as well as power and labor to hang them.

*\*Graphic design elements are priced separately and not included with TotalFlex® order.*



**FLOOR UNITS**

10'w x 8'h Floor Standing Unit

20'w x 8'h Floor Standing Unit

**TABLE TOP UNITS**

6'w x 40"h Table Top Unit

8'w x 40"h Table Top Unit

# FREEMAN

275 Bodwell St  
Avon, MA 02322  
(508) 894-5100 Fax: (469) 621-5608



DISCOUNT PRICE  
DEADLINE DATE  
SEPTEMBER 27, 2019

INCLUDE THE FREEMAN METHOD OF  
PAYMENT FORM WITH YOUR ORDER

NAME OF SHOW: **AFP 2019 / OCTOBER 20-23, 2019**

COMPANY NAME: \_\_\_\_\_ BOOTH #: \_\_\_\_\_ BOOTH SIZE: \_\_\_\_\_ X

CONTACT NAME : \_\_\_\_\_ PHONE #: \_\_\_\_\_

E-MAIL ADDRESS : \_\_\_\_\_

For Assistance, please call (508) 894-5100 to speak with one of our experts.

For fast, easy ordering, go to [www.freeman.com](http://www.freeman.com)

## TABLETOP UNIT

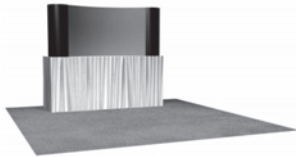

RENTAL			QTY	TOTAL
Size	Discount Price	Standard Price		
40"H x 6'W	1,146.00	1,604.40	_____	_____
40"H x 8'W	1,330.20	1,862.30	_____	_____

PURCHASE*			QTY	TOTAL
Size	Discount Price	Standard Price		
40"H x 6'W	1,193.20	1,670.50	_____	_____
40"H x 8'W	1,352.25	1,893.15	_____	_____

\*Shipping Not Included

**Rental Units Include:**  
Draped Table (select color below)  
Classic Carpet 9' X 10' (select color below)  
Installation & Dismantle of Exhibit  
Material Handling of Exhibit  
Nightly Vacuuming  
1-200 Watt Halogen Light (Power (500 watts) for LIGHTS only and Labor to hang lights)

**Purchase Units Include:**  
1-Case  
One Time Installation & Dismantle

Header Identification Sign - (white with black text) Indicate copy below:

**Fabric Panel Colors for All Units:**  Black  Gray  Blue

*\*Other Colors Also Available for Purchase Units*

**9' x 10' Classic Carpet:**  Black  Blue  Green  Gray  
 Latte  Midnight Blue  Plum  Red  Red Pepper  Tuxedo

**Table Drape:**

Black  Blue  Brown  Green  Flax  
 Gold  Gray  Plum  Red  White

## FLOOR UNIT

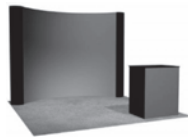

RENTAL			QTY	TOTAL
Size	Discount Price	Standard Price		
8'H x 8'W	1,880.25	2,632.35	_____	_____
8'H x 10'W	2,239.85	3,135.80	_____	_____

PURCHASE*			QTY	TOTAL
Size	Discount Price	Standard Price		
8'H x 8'W	2,704.80	3,786.70	_____	_____
8'H x 10'W	3,175.90	4,446.25	_____	_____

\*Shipping Not Included

**Rental Units Include:**  
Classic Carpet 9' X 10' (select color below)  
Installation & Dismantle of Exhibit  
Material Handling of Exhibit  
Nightly Vacuuming  
1-Podium - 8'H X 10'W unit only  
2-200 Watt Halogen Lights (Power (500 watts) for LIGHTS only and Labor to hang lights)

**Purchase Units Include:**  
2-Cases  
One Time Installation & Dismantle  
1-Podium - 8'H X 10'W unit only

Header Identification Sign - (white with black text) Indicate copy below:

**Fabric Panel Colors for All Units:**  Black  Gray  Blue

*\*Other Colors Also Available for Purchase Units*

**9' x 10' Classic Carpet:**  Black  Blue  Green  Gray  
 Latte  Midnight Blue  Plum  Red  Red Pepper  Tuxedo

All Classic carpet contain recycled content and are recyclable.

## CUSTOM GRAPHIC / PHOTO PANELS

Our custom graphic panels can dramatically enhance your exhibit's appearance.

Please check the box to have an Exhibitor Sales Specialist contact you to assist in creating a unique exhibit.

OPTIONAL ACCESSORIES			RENTAL			PURCHASE			
Part #	Description	Qty	Discount Price	Standard Price	Total	Qty	Discount Price	Standard Price	Total
1715800	2-200 Watt Halogen Light Kit	_____	231.70	324.40	_____	_____	298.00	417.20	_____
1715801	1-200 Watt Halogen Light Kit	_____	121.40	169.95	_____	_____	219.15	306.80	_____
1715802	Straight Shelf	_____	93.05	130.25	_____	_____	151.25	211.75	_____
1715803	Angled Shelf	_____	93.05	130.25	_____	_____	151.25	211.75	_____

## QUICK TIPS

\* If shipping literature or products, material handling rates will apply.

\* Order in advance to save time, money and ensure availability. **Orders received after the deadline date or without payment will be charged the Standard Price.**

### PURCHASE UNITS TOTAL COST

Sub-Total + 6.25% Tax = Total Cost

### RENTAL UNITS TOTAL COST

Sub-Total + 6.25% Tax = Total Cost

# SEEING IS BELIEVING

---

Quality graphics contribute significantly to the impact of your exhibit. With state-of-the-art design and printing capabilities, Freeman brings your banners, signage, and exhibit graphics to life in a larger-than-life way. Our graphics products redefine “high definition,” which means your brand has never been seen like this before.

- Photo-quality / high-resolution printing on a variety of rigid and rolled material including honeycomb, foam, Polyfoam, PVC, acrylic, fabric, vinyl and mesh materials
- Grand Format printers provide high-resolution digital printing of single and double-sided banners in virtually any size
- Electronic file transfer, in-house printing, and company-wide procedure standardization allow us to control quality, cost and scheduling on a nationwide basis
- Extensive resources ensure that last minute repairs and replacements are handled efficiently as needed, no matter where your event may be located



Call customer service at the number listed on the Quick Facts. For fast, easy ordering, go to [freeman.com](http://freeman.com)

## CREATING VISUAL EXCITEMENT

Quality graphics contribute significantly to the impact of your exhibit. Vivid colors and sharp images attract attention, build traffic, and communicate messages more effectively. Freeman has invested in the latest printing technology and has the skills to provide you with the finest high-resolution digital graphic reproduction available.

## STATE-OF-THE-ART CAPABILITIES

Freeman can provide four-color, photo-quality, high-resolution digital printing in virtually any size for banners, signage, exhibit graphics, and more. Each Freeman location has stand-alone printing capabilities, along with two additional graphic locations for additional support and for special requirements.

## SUPERIOR QUALITY CONTROL

Electronic file transfer, in-house printing, and company-wide standardization of procedures allow us to control quality, cost and scheduling for our customers on a nationwide basis. Last minute repairs and replacements are handled efficiently through our nationwide resources.

## DEPTH OF RESOURCES

- 5M UV roll printers provide grand format, four-color, high-resolution digital printing of single and double-sided banners up to 16' wide and virtually any size with seams.
- 3M Dye Sublimation printers provide 10' fabric graphics that work perfectly in our SmartWall panel system.
- UV flatbeds print directly to a variety of ridged materials and offer a 100% recyclable graphic when using a cardboard substrate.
- Freeman offers 100% recyclable substrates that can save you money and the environment.
- Large format Eco-Solvent printers produce high quality graphics for wall, carpet and window applications.
- 3M high speed digital cutters allow for precise cutting of multiple panel applications and also custom router graphic panels.
- Computer-aided graphic design & layout available for your assistance.

## REPRODUCTION AND INSTALLATION

- Suspended banners
- Accent graphic photo panels
- Large format signage and banners
- Logo reproduction
- Backlit displays and murals
- Four-color carpet image printing



# FREEMAN

275 Bodwell St  
Avon, MA 02322  
(508) 894-5100 Fax: (469) 621-5608



DISCOUNT PRICE  
DEADLINE DATE  
SEPTEMBER 27, 2019

INCLUDE THE FREEMAN METHOD OF  
PAYMENT FORM WITH YOUR ORDER

NAME OF SHOW: **AFP 2019 / OCTOBER 20-23, 2019**

COMPANY NAME: \_\_\_\_\_ BOOTH #: \_\_\_\_\_ BOOTH SIZE: \_\_\_\_\_ X

CONTACT NAME: \_\_\_\_\_ PHONE #: \_\_\_\_\_

E-MAIL ADDRESS: \_\_\_\_\_

For Assistance, please call (508) 894-5100 to speak with one of our experts.

For fast, easy ordering, go to [www.freeman.com](http://www.freeman.com)  
**GRAPHICS**

To order your graphics, complete this order form and attach your sign copy or electronic file.  
Please see artwork guidelines for electronic files on page 2 of this form.  
Note: All graphics are subject to a 100% Cancellation Charge.

### DIGITAL GRAPHICS

Freeman has the capabilities to provide you with the finest digital graphic reproduction available. Capabilities include four-color, photo-quality, high-resolution digital printing virtually any size for banners, signage, exhibit graphics and more.

\_\_\_\_\_ L X \_\_\_\_\_ W = \_\_\_\_\_ sq.ft.

sq. ft. \_\_\_\_\_ \$ 22.80 per sq. ft. discount price  
x or = \$ \_\_\_\_\_  
\$ 34.20 per sq. ft. standard price

- Minimum order per graphic 9 sq. ft. (1296 sq. in.)
- Double sq. ft. for double-sided graphics
- Round sq. ft. to next whole increment
- File conversion, retouching, cloning or color correcting may incur additional labor charges. (See reverse side for graphic guidelines.)

### LARGE DIGITAL GRAPHICS

Please call an Exhibitor Sales Specialist for price quotes on graphics over 80 sq. ft.

File Information:  
Electronic File Name \_\_\_\_\_  
Application \_\_\_\_\_  
PMS Colors \_\_\_\_\_

### Backing Material:

- |   |   |
|---|---|
| <input type="checkbox"/> Freeman Foam (Foamcore)        | <input type="checkbox"/> Masonite                                 |
| <input type="checkbox"/> Freeman PVC (PVC)              | <input type="checkbox"/> Plexi                                    |
| <input type="checkbox"/> Freeman HD Foam (Gatorfoam)    | <input checked="" type="checkbox"/> Freeman Honeycomb (Eco-Board) |
| <input type="checkbox"/> Freeman Polyfoam (Ultra Board) | <input type="checkbox"/> Other                                    |

The product offered has recycled content or has eco-friendly attributes and is 100% recyclable according to the manufacturer's specifications.

Vertical Horizontal Use Your Judgment For Sign Layout

Special Instructions \_\_\_\_\_

### STANDARD SIZES

#### CHOOSE YOUR SIZE:

QTY.	Discount Price	Standard Price	TOTAL
7" x 11" @ _____	52.95	79.45 =	_____
7" x 22" @ _____	54.65	82.00 =	_____
7" x 44" @ _____	67.55	101.35 =	_____
9" x 44" @ _____	87.55	131.35 =	_____
11" x 14" @ _____	52.95	79.45 =	_____
14" x 22" @ _____	65.80	98.70 =	_____
14" x 44" @ _____	136.85	205.30 =	_____
22" x 28" @ _____	136.85	205.30 =	_____
28" x 44" @ _____	200.65	301.00 =	_____
20" x 60" @ _____	N/A	N/A =	_____

(white only)

Note: File conversion, retouching, cloning or color may incur additional labor charges. (See reverse side for graphic guidelines.)

### INDICATE YOUR SIGN COPY HERE:

\* Please feel free to attach additional sign copy on separate page.

Vertical Horizontal Use Your Judgment For Sign Layout

Background Color: \_\_\_\_\_

Lettering Color: \_\_\_\_\_

TOTAL COST		
Sub-Total	+	6.25 % Tax = Total Cost

## CUSTOMER GUIDELINES FOR SUBMITTING GRAPHICS ARTWORK

*Our goal is to provide you with the best possible quality graphics for your event or exhibit. You can help us in that effort by providing digital art files using the following guidelines. If you are sending us completed, print-ready files, please pass the following information on to your graphics designer or art department. Artwork must be submitted in the proper resolution and/or file size to produce quality images. Please provide proper color matching information and proofs to ensure accurate color reproduction.*

### PLEASE PROVIDE THE FOLLOWING WHEN SUBMITTING ART

**RASTER ART** (photos, logos containing any continuous tone images):

- Art submitted at 1:1 (100%), resolution should be no less than 60 dpi (100 dpi preferred)
- Art submitted at 2:1 (50%), resolution should be no less than 120 dpi (200 dpi preferred)
- Art submitted at 4:1 (25%), resolution should be no less than 240 dpi (400 dpi preferred)

**VECTOR ART:**

- Logos should be vector and have outlined fonts (if provided as bitmap, please use high-res images)

**FONTS and LINKS**

- Supply all fonts used in your design (zip Mac fonts). If unsure how to collect fonts, convert them to outlines
- Supply all links used in your document. Use packaging feature if available. If unsure how to collect links, embed them in the file when saving.

**COLOR**

- If PMS color matching is required, please use original Pantone + Solid Coated swatches in your artwork. Modifying Pantone names will result in printing default color (CMYK)
- CMYK artwork will be produced "As Is". Our color output is balanced and vibrant.
- Convert RGB art to CMYK if possible.
- If you are sending Certified Color Proofs (Gracol, Swop, Fogra), please provide ICC file information used to print your samples. Best option would be to include ICC chart on your prints.

**ARTWORK IN THE STRUCTURE**

- Please note that any panels going in the metal frame will hide 1/4" of your art all the way around. If you have a continuous wall where individual panels are divided by metal, use 1.25" spacing in between each panel to account for gaps and the natural flow of the graphics.

### ACCEPTABLE FILE SOFTWARE

We are capable of working with both PC and MAC based software, and can accept art created with the ADOBE Creative Suite - Illustrator, InDesign, and Photoshop

Always provide the following:

- Native files with fonts and links (zipped)
- High-res PDF-X/4 exports of the files

### ACCEPTABLE FILE TYPES and SUPPORT FILES

**NATIVE FILES:**

- AI CLOUD (CC) file with Packaged supporting links and fonts. You may keep images linked but Packaging feature must be used.
- AI (CS6, CS5, CS4...) file with embedded links and outlined fonts
- EPS file with embedded links and outlined fonts
- INDD file with Packaged supporting links and fonts

**PRINT FILES:**

- High-res PDF-X/4 (preferred)
- AI with PDF content (choose this option when saving file)
- EPS files with embedded links and outlined fonts

**RASTER OR BITMAP ART:**

- Photoshop EPS (preferred, use 8-bit preview, Max, Quality JPG compression)
- PSD (make sure font layers are rasterized)
- TIFF, JPG (quality 8 and higher)

Mac users: Use Zip or Stuffit programs when submitting fonts other than OTF (Open Type Fonts)

### WAYS TO SEND ARTWORK

• Files below 10 MB can be delivered via email. Larger files may be posted to Freeman's FTP site. You may get the password and other needed information from your Freeman service representative in order to post files. However, a hard copy proof and backup of the files on CD-Rom/DVD may be required to be sent via overnight delivery in addition to posting the electronic files. Please call (508) 894-5100 for assistance.

# UNION JURISDICTIONS BOSTON, MASSACHUSETTS

We have provided these definitions to acquaint you with specific guidelines for labor. If you have any questions once you have read this, please address them to Show Management or to Freeman directly.

The unpacking, erection, assembling, dismantling, and packing of displays and equipment may be done by full-time employees of an exhibiting company. The official labor contractor for the exposition will have skilled craftsmen to assist exhibitors who wish to hire labor to perform these services. Arrangements for all temporary labor should be made through the official service contractor. Official labor order forms are included in the exhibitor service manual.

## MATERIAL HANDLING

Work rules require that the official material handling contractor off-load all equipment and display material from commercial carriers/common carriers or van lines. ***The use of fork trucks, pallet jacks and lift gates are permitted only by personnel of the official material handling contractor.*** Exhibitors are allowed to perform their own material handling, provided they meet all of the following criteria:

Personnel performing the work must be **bonafide, full-time company employees** of the exhibiting company.

They must be off-loading from a company owned truck or rental vehicle, or from a car, van or truck owned by personnel of the exhibiting company. All trucks, including co-owned or rental vehicles, over 24' in length will be off-loaded or loaded by the official material handling contractor.

They may use **only** hand-operated equipment, which they have provided; two-wheeled hand trucks and four-wheeled flat trucks are permitted. The use of fork trucks, pallet jacks, lift gates or any other mechanical equipment is not permitted by anyone other than the official drayage contractor.

## BOOTH LABOR

Exhibitors are allowed to set-up and/or dismantle their own booths, provided that they use their own **bonafide, full-time employees**. Please advise them not to bring outside labor of any kind.

## TIPPING

Our Work Rules prohibit the SOLICITATION of tips by any of our employees. Our employees are paid excellent wages denoting a professional status and we feel that tipping is not necessary. Should you be SOLICITED for a tip, please report the incident to our Service Center as soon as possible.

# LET US DO THE HEAVY LIFTING

Freeman specialists are ready to assist you with all of your exhibit requests, from beginning to end. And when it comes to installing and dismantling exhibits, we make no exceptions. Whether it's shipping and storage, emergency on-site repairs, basic installation and dismantling or support service coordination, including electrical, furnishings and more, Freeman has the resources and capabilities to ensure the most successful show experience possible.



Call customer service at the number listed on the Quick Facts. For fast, easy ordering, go to [www.freeman.com](http://www.freeman.com)

Freeman installation & dismantling experts work closely with you to coordinate every phase of your trade show participation, including:

- Pre-planning and budget consultation
- Skilled labor coupled with support services coordination - electrical, furnishings, floral, transportation, and audio visual
- On-site supervisors with dedicated floor managers
- Full, in-house carpentry for emergency repairs and refurbishing
- Post-show evaluations focused on incremental improvement to meet rapidly changing market conditions based upon customer feedback
- Post-show evaluations that help identify small changes that make big impacts

## ON-SITE SUPERVISION

You may wish to supervise labor on your own, but if you need assistance, Freeman installation & dismantling experts will get the job done as an extension of your team.

---

### If You Use Freeman Staff

Exhibits can be set up prior to your arrival under the direction of Freeman I&D supervisors.



01/17 | 55774

# FREEMAN

275 Bodwell Street  
Avon, MA 02322

(508) 894-5100 • Fax: (469) 621-5608



DISCOUNT PRICE  
DEADLINE DATE  
SEPTEMBER 27, 2019

INCLUDE THE FREEMAN METHOD OF  
PAYMENT FORM WITH YOUR ORDER

NAME OF SHOW: **AFP 2019 / OCTOBER 20-23, 2019**

COMPANY NAME: \_\_\_\_\_ BOOTH #: \_\_\_\_\_

CONTACT NAME: \_\_\_\_\_ PHONE #: \_\_\_\_\_

E-MAIL ADDRESS: \_\_\_\_\_

For Assistance, please call (508) 894-5100 to speak with one of our experts.

For fast, easy ordering, go to [www.freeman.com](http://www.freeman.com)

## DISPLAY LABOR (One Hour Minimum per Worker)

Description	Advance Price	Show Site Price
<b>Straight Time-</b> 8:00 A.M. to 4:30 P.M. Monday through Friday.....	\$162.00	\$226.75
<b>Overtime-</b> 4:30 P.M. to 8:00 A.M. Monday through Friday and All Day Saturday.....	\$241.75	\$338.50
<b>Double Time-</b> All Day Sunday and Holidays.....	\$290.25	\$406.25

- Show Site prices will apply to all labor orders placed at show site.
  - Price is per person/per hour.
  - Start time guaranteed only at start of working day.
  - One hour minimum per person - labor thereafter is charged in half (1/2) hour increments.
  - Labor must be canceled in writing, 24 hours in advance to avoid a one (1) hour cancellation fee per worker
  - When scheduling dismantle labor, be sure to allow sufficient time for empty containers to be returned to your booth.
  - Freeman supervised jobs will be completed at our discretion prior to show opening and before the hall must be cleared. **Please include setup plan/photo, special instructions & inbound shipping information with this order.**
- Union Holidays: New Years Day, Martin Luther King Day, President's Day, Good Friday, Patriot's Day, Memorial Day, Independence Day, Labor Day, Columbus Day, Veteran's Day, Thanksgiving Day, Christmas Day.*

## INSTALLATION LABOR

- Freeman Supervised Labor - Please complete the reverse side of this form.**
- Installation of your exhibit will be completed at our discretion prior to show opening.
  - The charge for this service is 30% of the total installation labor bill, with a minimum of \$45.00.

Emergency contact: \_\_\_\_\_ Phone Number: \_\_\_\_\_

- Exhibitor Supervised Labor (Supervisor must check in at Service Desk to pick up labor)**

Supervisor will be: \_\_\_\_\_ Phone Number: \_\_\_\_\_

Date	Start Time	No. of People	Approx. Hrs. per Person	Total Hrs.	Hourly Rate	Estimated Total Cost
_____	_____	_____ x _____	_____ = _____	_____ @ \$ _____	= \$ _____	
_____	_____	_____ x _____	_____ = _____	_____ @ \$ _____	= \$ _____	
_____	_____	_____ x _____	_____ = _____	_____ @ \$ _____	= \$ _____	
Freeman Supervision (30%/\$45.00)						= \$ _____
Tax						= \$ <b>(N/A)</b>
Total Installation						= \$ _____

## DISMANTLE LABOR

- Freeman Supervised Labor - Please complete the reverse side of this form.**
- Freeman is not responsible for product or literature that is not properly packed and labeled by exhibitor.
  - The charge for this service is 30% of the total dismantle labor bill, with a minimum of \$45.00.

Emergency contact: \_\_\_\_\_ Phone Number: \_\_\_\_\_

- Exhibitor Supervised Labor (Supervisor must check in at Service Desk to pick up labor)**

Supervisor will be: \_\_\_\_\_ Phone Number: \_\_\_\_\_

Date	Start Time	No. of People	Approx. Hrs. per Person	Total Hrs.	Hourly Rate	Estimated Total Cost
_____	_____	_____ x _____	_____ = _____	_____ @ \$ _____	= \$ _____	
_____	_____	_____ x _____	_____ = _____	_____ @ \$ _____	= \$ _____	
_____	_____	_____ x _____	_____ = _____	_____ @ \$ _____	= \$ _____	
Freeman Supervision (30%/\$45.00)						= \$ _____
Tax						= \$ <b>(N/A)</b>
Total Dismantle						= \$ _____

Freeman installation & dismantle labor

NAME OF SHOW: **AFP 2019 / OCTOBER 20-23, 2019**

COMPANY NAME: \_\_\_\_\_

BOOTH#: \_\_\_\_\_

CONTACT NAME: \_\_\_\_\_

PHONE#: \_\_\_\_\_

**FREEMAN SUPERVISED LABOR**

***IN ORDER TO BETTER SERVE YOU - PLEASE COMPLETE THE FOLLOWING INFORMATION IF YOUR DISPLAY IS TO BE SET-UP AND/OR DISMANTLED BY FREEMAN I&D AND YOU WILL NOT BE PRESENT TO SUPERVISE THE INSTALLATION AND/OR DISMANTLE.***

**INBOUND SHIPPING & SET UP INFORMATION**

Freight will be shipped to Warehouse \_\_\_\_\_ Show Site \_\_\_\_\_ Date Shipped \_\_\_\_\_

Total No. of: \_\_\_\_\_ Crates \_\_\_\_\_ Cartons \_\_\_\_\_ Fiber Cases \_\_\_\_\_

Setup Plan/Photo: Attached \_\_\_\_\_ To Be Sent With Exhibit \_\_\_\_\_ In Crate No. \_\_\_\_\_

Carpet: With Exhibit \_\_\_\_\_ Rented From Freeman \_\_\_\_\_ Color \_\_\_\_\_ Size \_\_\_\_\_

Electrical Placement: \_\_\_\_\_ Drawing Attached Drawing With Exhibit Electrical Under Carpet \_\_\_\_\_

Comments: \_\_\_\_\_

Graphics: With Exhibit \_\_\_\_\_ Shipped Separately \_\_\_\_\_

Comments: \_\_\_\_\_

Special Tools/Hardware Required: \_\_\_\_\_

**OUTBOUND SHIPPING INFORMATION**

**SHIP TO:** \_\_\_\_\_  
\_\_\_\_\_  
\_\_\_\_\_  
\_\_\_\_\_

**Select a Carrier:**

**Freeman Exhibit Transportation:**

**Other Carrier:**

No need to schedule your outbound shipment.  
Charges will appear on your Freeman invoice.

Carrier Name: \_\_\_\_\_  
Carrier Phone: \_\_\_\_\_

Freeman will make arrangements for all Freeman Exhibit Transportation shipments.  
Arrangements for pick-up by other carriers is the responsibility of the exhibitor.

**Select Level of Service:**

- 1 Day: Delivery next business day
- 2 Day: Delivery by 5:00 PM second business day
- Deferred: Delivery within 3-5 business days
- Standard Ground
- Specialized: Pad wrapped, uncrated or truckload

**Freight Charges:**

Same as ship to  
Bill To: \_\_\_\_\_

**Select Shipment Options: (if applicable)**

- Have loading dock
- Inside delivery
- Pad wrap required
- Do not stack
- Lift gate required
- Air ride required
- Residential

**In the event your selected carrier fails to show on final move-out day, please select one of the following options:**

- Reroute via Freeman's choice
- Deliver back to Freeman warehouse at Exhibitor's expense.

**PLEASE NOTE: Freeman is not responsible for product or literature that is not properly packed and labeled by exhibitor.**

**FREEMAN installation & dismantle labor**

# FREEMAN

275 Bodwell Street  
Avon, MA 02322  
(508) 894-5100 • Fax: (469) 621-5608



**DISCOUNT PRICE  
DEADLINE DATE  
SEPTEMBER 27, 2019**

**INCLUDE THE FREEMAN  
METHOD OF PAYMENT WITH  
YOUR ORDER**

NAME OF SHOW: AFP 2019 / OCTOBER 20-23, 2019

COMPANY NAME: \_\_\_\_\_ BOOTH #: \_\_\_\_\_

CONTACT NAME: \_\_\_\_\_ PHONE #: \_\_\_\_\_

E-MAIL ADDRESS: \_\_\_\_\_

For Assistance, please call (508) 894-5100 to speak with one of our experts.

## CORD INSTALLATION LABOR

	Advance	Show Site
<b>Straight Time-</b> 8:00 A.M. to 4:30 P.M. Monday through Friday .....	\$162.00	\$226.75
<b>Overtime-</b> 4:30 P.M. to 8:00 A.M. Monday through Friday, all day Saturday .....	\$241.75	\$338.50
<b>Double Time-</b> All Day Sunday and Holidays.....	\$290.25	\$406.25

•Price is per person/per hour  
•Supervisor must check in at Service Desk to pick up labor  
•Labor must be canceled in writing, 24 hours in advance to avoid a one (1) hour cancellation fee per worker

**Utility services for all 120V power provided by the facility does not include the installation of cords to specific areas within the booth space. Freeman labor, display company labor or the exhibitor can perform this work. Rental carpeting and padding will not be installed until cord installation is completed.**

**\*High voltage (208V and over), please contact the facility's electrical department.**

**Freeman Supervised Labor**

- Freeman must receive detailed blueprints/floor plan's for power distributed under carpet.
- Installation of electrical cords will be completed at our discretion prior to exhibitor move-in.
- The charge for this service is 30% of the total installation labor bill, with a minimum of \$45.00.
- A detailed floor plan must accompany this order.

Emergency Contact: \_\_\_\_\_ Phone Number: \_\_\_\_\_

**Exhibitor Supervised Labor**

Name of supervisor \_\_\_\_\_ Phone Number: \_\_\_\_\_

**\*Start times cannot always be guaranteed.**

- If no time is provided, labor will be available on a first-come, first serve basis only.
- Exhibitors supervising the labor themselves should visit the Freeman service center to pick up labor.
- Carpet will not be installed until cords have been laid.

Date	Start Time	No. of People	Approx. Hrs. per Person	Total Hrs.	Hourly Rate	Estimated Total Cost
_____	_____	_____	x _____ = _____	_____	@ \$ _____ = \$ _____	_____
_____	_____	_____	x _____ = _____	_____	@ \$ _____ = \$ _____	_____
Freeman Supervision (30%/\$45.00)						= \$ _____
Total Installation						= \$ _____

## CORD DISMANTLE LABOR

- Dismantle labor will be charged at 50% of the total install time rounded to the next half hour (1 hour minimum)
- Cord dismantle will be done on straight time whenever possible.

Date	No. of People	Approx. Hrs. per Person	Total Hrs.	Hourly Rate	Estimated Total Cost
_____	_____	x _____ = _____	_____	@ \$ _____ = \$ _____	_____

## CORD RENTAL

Description	Price	Quantity
15' Flat Cord .....	<b>\$25.00*</b>	_____
25' Flat Cord .....	<b>\$35.00*</b>	_____
50' Flat Cord .....	<b>\$45.00*</b>	_____
Tape to cover cords.....	<b>\$25.00/roll*</b>	_____

There will be a minimum charge of \$25.00 to cover cords with tape.  
Larger areas and multiple electrical drops may require more than one roll.

**Subtotal** \_\_\_\_\_  
**\*+6.25% Mass Tax** \_\_\_\_\_  
**Total Cost** \_\_\_\_\_

(482532)

**FREEMAN electrical/internet cord labor**

## TERMS & CONDITIONS

1. Straight time rates apply to labor calls between the hours of 8:00 a.m. and 4:30 p.m., Monday through Friday. Overtime rates apply to labor calls before 8:00 a.m. and after 4:30 p.m., Monday through Friday, Saturdays, Double time rates apply to labor calls all day Sundays and Holidays.
2. Labor rates are based on current wage scales and are subject to change in the event of a wage increase after rates have been published.
3. A minimum charge of one hour is applicable to all labor requests. Additional time on the same day is billed in 1/2 hour increments. Continuations to another day are a minimum of 1 hour. A one hour minimum charge will apply to pick up cords.
4. Charges for labor commence at time of dispatch to service the labor call. A one hour minimum will apply if an exhibitor representative is not present at the time of call or reschedules the call, unless 24 hour advance notice is received in writing.
5. Labor charges will include the time for laborers to gather the necessary tools and material for the job, have their work checked by the client and return the tools and material to the supply area.
6. Every effort will be made to dispatch laborers as requested but start times cannot be guaranteed. 8:00 a.m. calls will be filled on a first come first served basis as orders are received.
7. Claims will not be considered, or adjustments made, unless filed in writing, by Exhibitor, prior to the close of the event.
8. Freeman is not responsible for any damage or loss caused by the loss of power beyond its control and Exhibitor agrees to hold Freeman, its officers, directors, employees and agents harmless from such power loss. IN NO EVENT SHALL FREEMAN BE LIABLE FOR ANY INDIRECT OR CONSEQUENTIAL DAMAGES (INCLUDING WITHOUT LIMITATION LOST PROFITS) EVEN IF ADVISED OF THE POSSIBILITY OF SUCH DAMAGES, WHETHER UNDER THEORY OF CONTRACT, TORT (INCLUDING NEGLIGENCE), PRODUCTS LIABILITY OR OTHERWISE. Exhibitor shall indemnify and hold harmless Freeman, its officers, directors, employees, and agents from and against any and all claims, liabilities, damages, fines penalties or costs of whatsoever nature (including reasonable attorneys' fees) arising out of or in any way connected with Exhibitor's actions or omissions under this Agreement.

### EXAMPLE OF PLAN AND INFORMATION REQUIRED TO COMPLETE FLOORWORK

Please indicate the following on the floor plan.

1. Location and load of main power drop - please provide specific dimensions and wattages/amperages.
2. Location and load of all outlets - please provide specific dimensions and wattages/amperages.
3. Booth orientation - please provide surrounding aisle and/or booth numbers

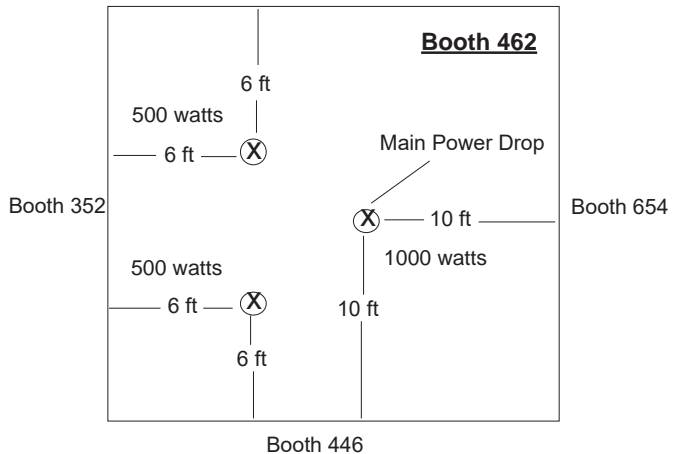

#### IN LINE BOOTHS

Power is run or dropped to in line booths along the back walls or drupe line of multi booth sections. The "main power locations" therefore are always located at the back of in line and penninsula booths. Outlets may not be in the exact center of the back wall. 120 volt outlets are shared by back to back booths.

Example: Outlet = ⊗

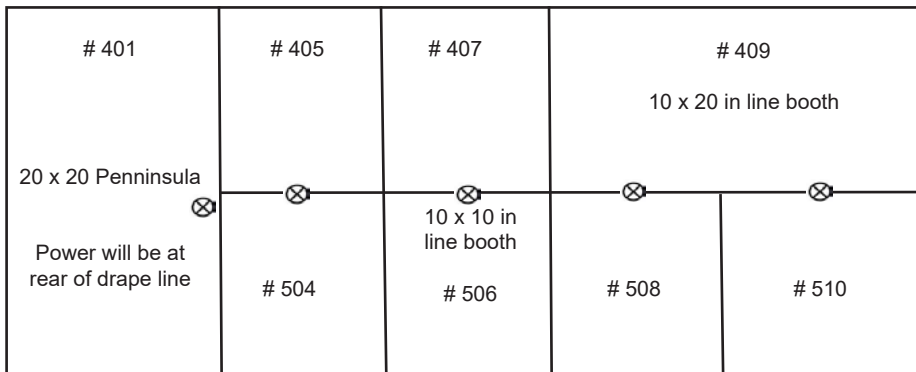

# ELECTRICAL/INTERNET CORD LABOR GRID

SHOW NAME \_\_\_\_\_ DATES \_\_\_\_\_

COMPANY NAME \_\_\_\_\_ BOOTH # \_\_\_\_\_

ADJACENT AISLE OR BOOTH # \_\_\_\_\_

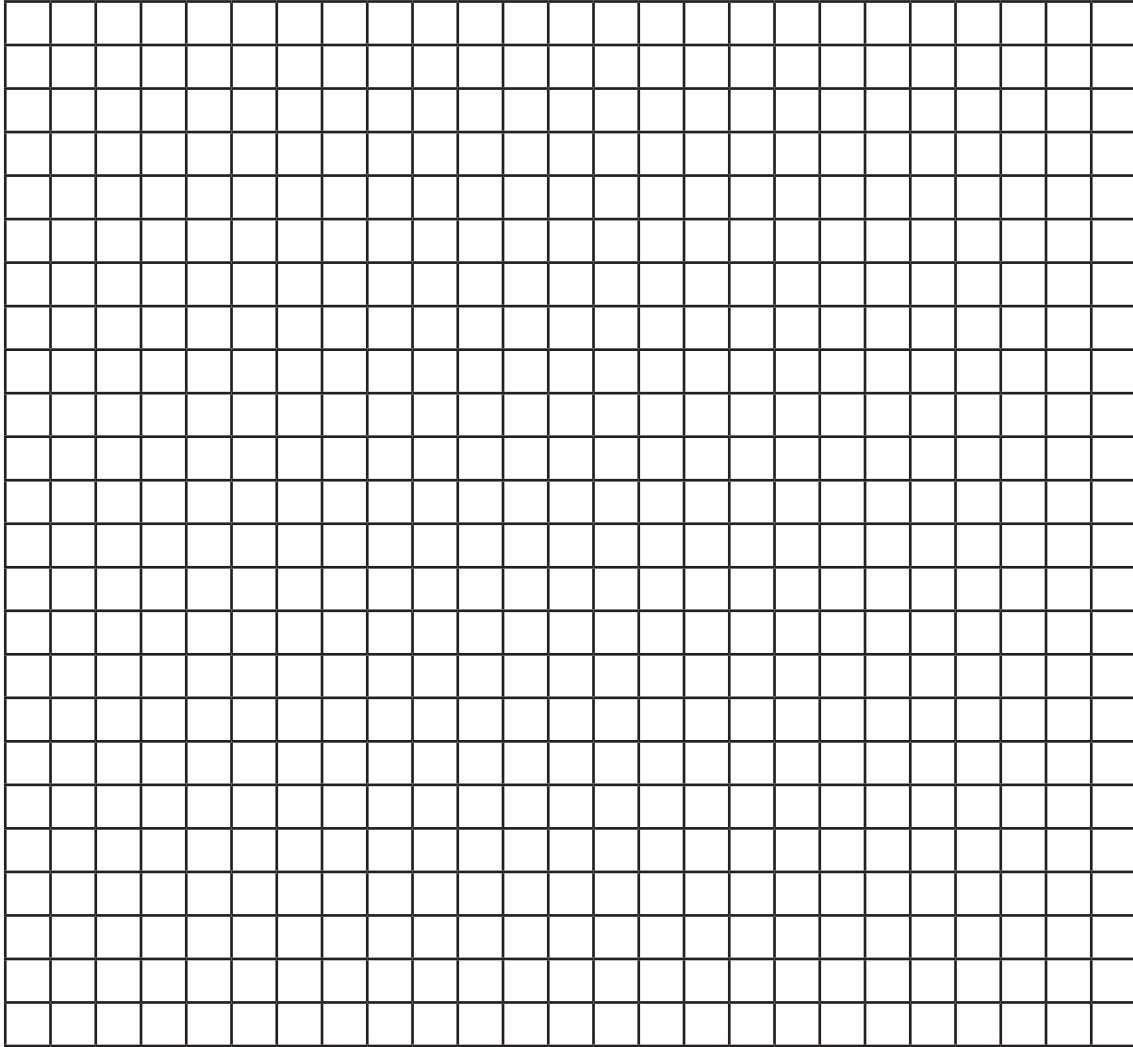

ADJACENT AISLE OR BOOTH # \_\_\_\_\_

A measurement scale can be applied to reflect the size of your booth.

10 x 10 use 1 square = 1/4 foot

20 x 20 use 1 square = 1/2 foot

40 x 40 use 1 square = 1 foot

# FREEMAN

275 Bodwell Street  
Avon, MA 02322  
(508) 894-5100 • Fax: (469) 621-5608



DISCOUNT PRICE  
DEADLINE DATE  
SEPTEMBER 27, 2019

INCLUDE THE FREEMAN METHOD OF  
PAYMENT FORM WITH YOUR ORDER

NAME OF SHOW: **AFP 2019 / OCTOBER 20-23, 2019**

COMPANY NAME: \_\_\_\_\_ BOOTH #: \_\_\_\_\_

CONTACT NAME: \_\_\_\_\_ PHONE #: \_\_\_\_\_

E-MAIL ADDRESS: \_\_\_\_\_

For Assistance, please call (508) 894-5100 to speak with one of our experts.

For fast, easy ordering, go to [www.freeman.com](http://www.freeman.com)

## FORKLIFT RIGGING EQUIPMENT AND LABOR

- Straight Time -** 8:00 A.M. to 4:30 P.M. Monday through Friday
- Overtime -** 4:30 P.M. to 8:00 A.M. Monday through Friday and All Day Saturday
- Double Time -** All Day Sunday and Holidays

- Show site prices will apply to all labor orders placed at show site
  - Start time guaranteed only at start of working day
  - One hour minimum - labor thereafter is charged in half (1/2) hour increments
  - Supervisor must check in at Service Desk to pick up labor
  - When scheduling dismantle labor, be sure to allow sufficient time for empty containers to be returned to your booth
- Union Holidays: New Years Day, Martin Luther King Day, President's Day, Good Friday, Patriot's Day, Memorial Day, Independence Day, Labor Day, Columbus Day, Veteran's Day, Thanksgiving Day, Christmas Day.**

Part#	Description	Advance Price	Show Site Price
<b>FORKLIFT LABOR</b>			
304050	Forklift w/operator - up to 5,000 lbs - ST.....	\$ 402.75	\$ 564.00
304051	Forklift w/operator - up to 5,000 lbs - OT.....	\$ 562.50	\$ 787.50
304052	Forklift w/operator - up to 5,000 lbs - DT.....	\$ 659.25	\$ 923.00
3040100	Forklift w/operator - up to 10,000 lbs - ST.....	\$ 487.75	\$ 683.00
3040101	Forklift w/operator - up to 10,000 lbs - OT.....	\$ 647.00	\$ 906.00
3040102	Forklift w/operator - up to 10,000 lbs - DT.....	\$ 744.25	\$1,042.00
304040	Forklift w/operator - 4-Stage - ST.....	\$ 572.25	\$ 801.25
304041	Forklift w/operator - 4-Stage - OT.....	\$ 732.00	\$ 1,025.00
304042	Forklift w/operator - 4-Stage - DT.....	\$ 824.25	\$ 1,154.00
<b>RIGGING LABOR</b>			
3020100	Rigger - ST.....	\$ 162.00	\$ 226.75
3020101	Rigger - OT.....	\$ 241.75	\$ 338.50
3020102	Rigger - DT.....	\$ 290.25	\$ 406.25
<b>EQUIPMENT</b>			
3090600	Forklift Cage.....	\$ 56.00	\$ 78.50
3090700	Forklift Boom.....	\$ 56.00	\$ 78.50
3090800	Pallet Jack.....	\$ 56.00	\$ 78.50

Please check here if you need a Scissorlift for booth work.

### INSTALLATION

Part #	Description	Date	Start Time	# of Equip/ Person	Approx Hrs per Person	Total Hours	Hourly Rate	Estimated Total Cost
Describe work to be done: _____							Sub-Total	
_____							6.25% Tax	N/A
_____							<b>Total</b>	

### DISMANTLE

Part #	Description	Date	Start Time	# of Equip/ Person	Approx Hrs per Person	Total Hours	Hourly Rate	Estimated Total Cost
Describe work to be done: _____							Sub-Total	
_____							6.25% Tax	N/A
_____							<b>Total</b>	

(482532)

FREEMAN forklift / rigging labor

*before event*

*during the event*

*after event*

from your location  
or previous event

to your location  
or next event

event venue

venue  
dock

**your exhibit**

venue  
dock

**advance  
warehouse**

storage for empty containers



*advance warehouse*

where exhibit materials are  
stored before an event



*shipping*

transport to the venue's shipping  
dock then from the shipping dock to  
the next event or customer location



*material handling*

move items from the dock, to the  
exhibit, back to the dock after the show

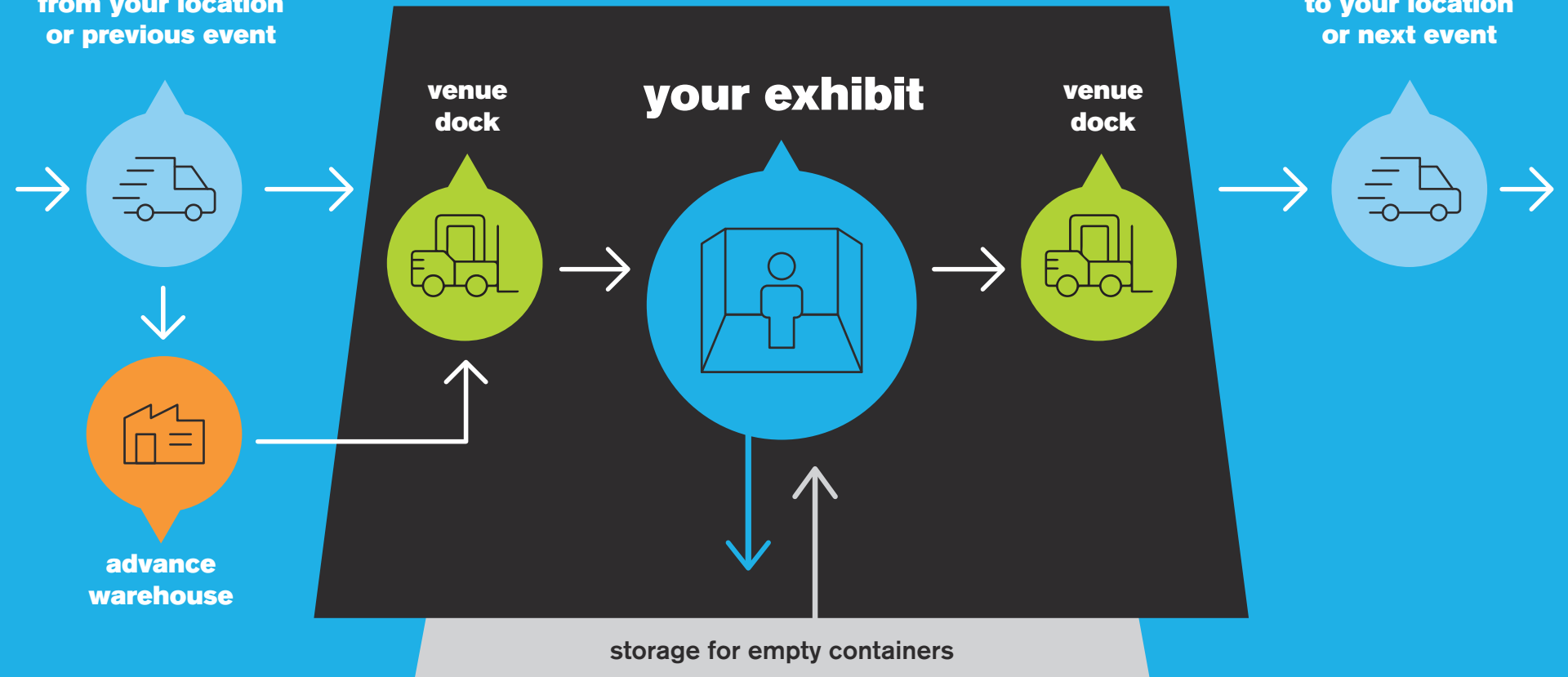

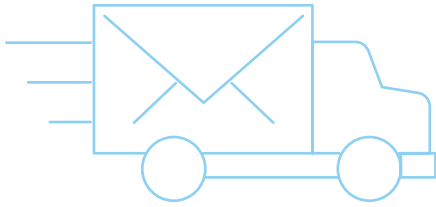

# TRANSPORTATION SERVICE, FULLY LOADED.

Our convenient, affordable package puts productivity in overdrive.

Turn to Freeman for one-stop transportation services. Our all-inclusive round trip standard ground shipping and material handling package means transporting materials to any exhibit location has never been easier or more affordable. Plus, Freeman works directly with you and show site decision makers to streamline the process, so it's faster than ever to get on the road to success.

## The Freeman Exhibit Transportation promise:

- ALL-INCLUSIVE PRICING WITH NO ADDITIONAL FEES FOR PICKUPS AND DELIVERIES, INCLUDING WEEKEND AND NIGHT SERVICE
- PICK-UP AND TRANSPORTATION FROM POINT OF ORIGIN TO YOUR CHOICE OF EITHER ADVANCE WAREHOUSE OR SHOW SITE
- ON-SITE TRANSPORTATION EXPERTS ARE AVAILABLE BEFORE, DURING AND AFTER THE SHOW
- RELIABLE CUSTOMER SERVICE SEVEN DAYS A WEEK, OFFERING COMPLETE SHIPMENT VISIBILITY AND EXPERT SUPERVISION
- PRE-PRINTED SHIPPING LABELS AND OUTBOUND PAPERWORK

## Benefits:

- TURNKEY PRICING ENSURES PRECISE BUDGETING
- NO ADDITIONAL HANDLING, PICK-UP OR DELIVERY FEES
- NO ADDITIONAL FUEL SURCHARGES OR OVERTIME SURCHARGES
- NO CARRIER WAITING TIME FEES
- EXPERIENCED ON-SITE TRANSPORTATION REPS FROM MOVE-IN THROUGH MOVE-OUT
- LTL (LESS THAN TRUCK LOAD) SHIPPING

\*Services apply to destinations anywhere in the Continental U.S.



To take advantage, call **1-800-995-3579** or email **[exhibit.transportation@freeman.com](mailto:exhibit.transportation@freeman.com)** for a quote.

# RESULTS, DELIVERED

---

With more than 90 years of experience in the events industry, no one understands exhibit transportation better than Freeman. Our transportation services are a seamless extension of the premium products that exhibitors around the world rely on time and time again.

Between our all-inclusive pricing and superior customer service, Freeman Exhibit Transportation is the most reliable, convenient and cost-effective solution available. Our team of experts has the ability to quickly respond to changes when necessary, remaining entirely responsive to all of your show requirements, whenever and wherever they arise.

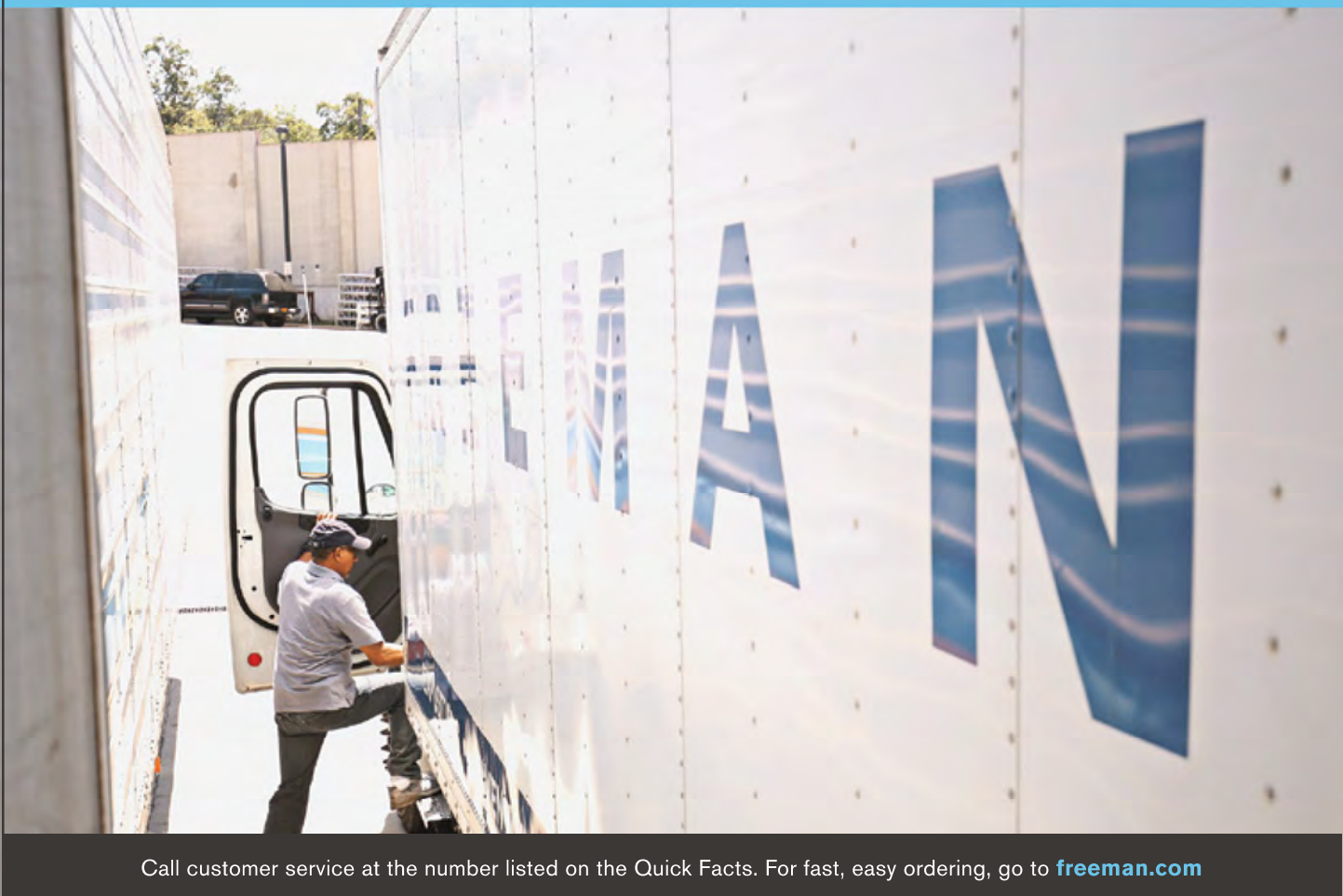

Call customer service at the number listed on the Quick Facts. For fast, easy ordering, go to [freeman.com](http://freeman.com)

## EXHIBIT TRANSPORTATION SERVICES

Freeman Exhibit Transportation is an EPA Smartway Partner and is dedicated to reducing carbon emissions related to the transportation of goods. Renting or shipping items locally saves on carbon emissions and your shipping footprint.

### Freeman Exhibit Transportation promise:

- ALL-INCLUSIVE PRICING WITH NO ADDITIONAL FEES FOR PICKUPS AND DELIVERIES, INCLUDING WEEKEND AND NIGHT SERVICE
- ONE CONVENIENT INVOICE ENCOMPASSING ALL FREEMAN SHOW SERVICES
- ON-SITE TRANSPORTATION EXPERTS ARE AVAILABLE BEFORE, DURING AND AFTER THE SHOW
- RELIABLE CUSTOMER SERVICE SEVEN DAYS A WEEK, OFFERING COMPLETE SHIPMENT VISIBILITY AND EXPERT SUPERVISION

### Questions?

For more information regarding our services, rates, shipment deadlines, documentation requirements, ordering and the terms and conditions of our service offerings, please visit [freeman.com](http://freeman.com)

Continental U.S. Exhibitors: Contact our exhibit transportation experts at **800.995.3579** or via email at [exhibit.transportation@freeman.com](mailto:exhibit.transportation@freeman.com)

International Exhibitors: Contact our exhibit transportation experts at **+1.817.607.5183** or via email at [international.freight@freeman.com](mailto:international.freight@freeman.com)

**DON'T FORGET ABOUT INBOUND SHIPPING! COMPLETE AND SEND THE ORDER FORM**

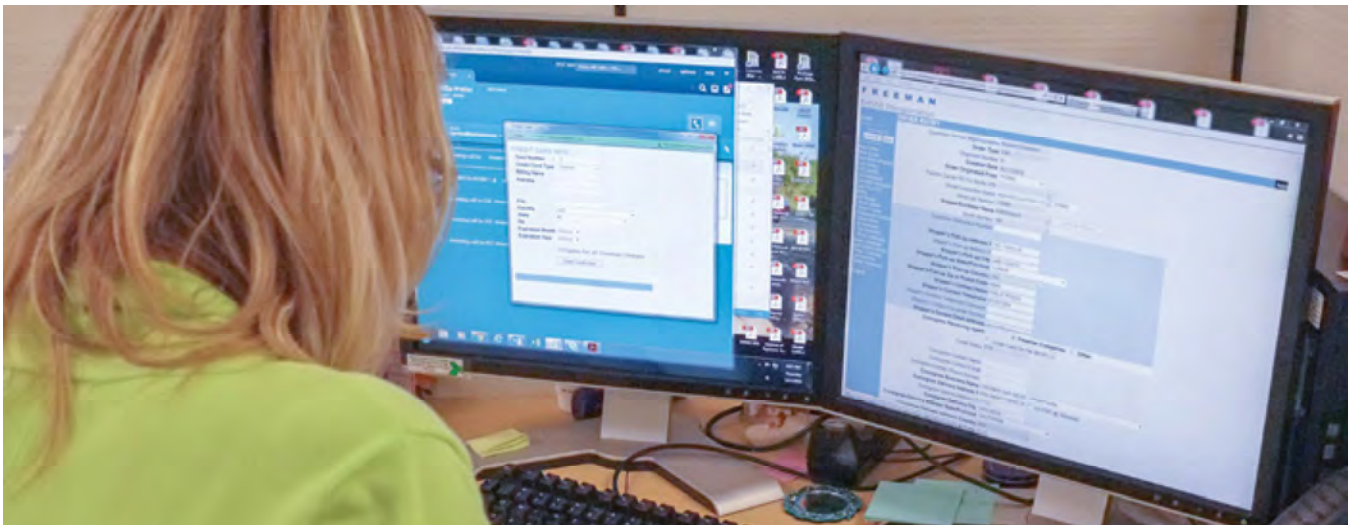



**COMPLETE THIS FORM ONLY IF YOU ARE SHIPPING YOUR EXHIBIT MATERIALS BY FREEMAN EXHIBIT TRANSPORTATION**

NAME OF SHOW: **AFP 2019 / OCTOBER 20-23, 2019**

COMPANY NAME: \_\_\_\_\_ BOOTH #: \_\_\_\_\_ BOOTH SIZE: \_\_\_\_\_ X  
 CONTACT NAME : \_\_\_\_\_ PHONE #: \_\_\_\_\_  
 E-MAIL ADDRESS : \_\_\_\_\_

For Assistance, please call applicable number listed above to speak with one of our experts.

For fast, easy ordering, go to [www.freeman.com](http://www.freeman.com)

**EXHIBIT TRANSPORTATION**

**TIPS FOR EASY ORDERING**

- Credit card information must be on file prior to pick up, as charges will be included on your show services invoice.
- International Exhibitors remember - Shipments originating from countries other than the US must be cleared through customs. Please call for additional information:  
(800) 995-3579 Toll Free US & Canada  
(817) 607-5183 Local & International

COMPLETE THE FOLLOWING ITEMS ON THIS FORM:

**PICK UP INFORMATION**

Requested Pick Up Date: \_\_\_\_\_  
 SHIPPER NAME \_\_\_\_\_  
 SHIPPER ADDRESS \_\_\_\_\_  
 \_\_\_\_\_  
 \_\_\_\_\_  
 \_\_\_\_\_  
 (City) (State) (Zip Code)

**DESTINATION**

- I will be shipping to the **WAREHOUSE**
- FREEMAN / Exhibiting Company Name / Booth #**  
**AFP 2019**  
 C/O: FREEMAN  
 25 DOHERTY AVE  
 AVON, MA 02322  
 MUST BE DELIVERED BY OCTOBER 11, 2019
- I will be shipping to **SHOW SITE**
- FREEMAN / Exhibiting Company Name / Booth #**  
**AFP 2019**  
 C/O: FREEMAN  
 BOSTON CONVENTION & EXHIBITION CENTER  
 415 SUMMER ST  
 BOSTON, MA 02210-1709  
 CANNOT BE DELIVERED BEFORE OCTOBER 18, 2019

**TYPE OF SERVICE**

- Next Day Air: Delivery next business day by 5:00 PM  
 Second Day Air: Delivery second business day by 5:00 PM  
 3-5 Day Service: Delivery within 3 - 5 business days  
 Declared Value \$ \_\_\_\_\_  
**Air Transportation charges are billed by Dimensional or Actual Weight, whichever is greater.**
- Standard Ground: Dependent on distance  
 Expedited Ground: Tailored to specific requirements  
 Specialized: Pad wrapped, uncrated, truck load

**SHIPPING INFORMATION**

**Items to be shipped**

Number of Pieces	Est. Weight
____ Crates (wooden)	_____
____ Cartons (cardboard)	_____
____ Cases/Trunks (fiber) (color _____)	_____
____ Skids/Pallets	_____
____ Carpet (color _____)	_____
____ Other ( _____ )	_____
____ Total	_____

Size of largest piece: (H) \_\_\_\_\_ (W) \_\_\_\_\_ (L) \_\_\_\_\_

**NOTE: Shipments will be weighed and measured prior to delivery.**

**OUTBOUND SHIPPING**

- I would like to schedule outbound Freeman Exhibit Transportation. Please provide me with a Material Handling Agreement at show site for my shipping instructions and signature. So we may print your Outbound Material Handling Agreement and labels, please complete the following information **if different from pick up address:**

Ship to address:  
 \_\_\_\_\_  
 \_\_\_\_\_  
 \_\_\_\_\_  
 \_\_\_\_\_

Number of Labels : \_\_\_\_\_

FAX THIS COMPLETED FORM VIA:

E-mail:  
[exhibit.transportation@freeman.com](mailto:exhibit.transportation@freeman.com)  
 or  
 Fax: (469) 621-5810

A TRANSPORTATION SPECIALIST WILL CALL YOU TO CONFIRM RECEIPT OF SHIPMENT REQUEST AND FINALIZE DETAILS.

SHOW # (482532)

**F R E E M A N**

**R U S H**

**DO NOT DELAY**

**F R E E M A N**

**R U S H**

**DO NOT DELAY**

**RECEIVING DATE BEGINS: SEPTEMBER 20, 2019**

**RECEIVING DATE BEGINS: SEPTEMBER 20, 2019**

**DEADLINE DATE IS: OCTOBER 11, 2019**

**DEADLINE DATE IS: OCTOBER 11, 2019**

**TO:** \_\_\_\_\_

*EXHIBITOR NAME*

**TO:** \_\_\_\_\_

*EXHIBITOR NAME*

**C/O: FREEMAN  
25 DOHERTY AVE  
  
AVON, MA 02322**

**C/O: FREEMAN  
25 DOHERTY AVE  
  
AVON, MA 02322**

**WAREHOUSE**

**WAREHOUSE**

**EVENT:** \_\_\_\_\_ *AFP 2019*

**EVENT:** \_\_\_\_\_ *AFP 2019*

**BOOTH NO:** \_\_\_\_\_ **NO.** \_\_\_\_\_ **OF** \_\_\_\_\_ **PCS**

**BOOTH NO:** \_\_\_\_\_ **NO.** \_\_\_\_\_ **OF** \_\_\_\_\_ **PCS**

THE ABOVE LABELS ARE PROVIDED FOR YOUR CONVENIENCE.  
PLACE ONE ON EACH PIECE SHIPPED TO ENSURE PROPER DELIVERY.  
IF MORE LABELS ARE NEEDED, COPIES ARE ACCEPTABLE.

**F R E E M A N**

**F R E E M A N**

**R U S H**

**R U S H**

**DO NOT DELAY**

**DO NOT DELAY**

**CANNOT DELIVER BEFORE OCTOBER 18, 2019**

**CANNOT DELIVER BEFORE OCTOBER 18, 2019**

TO: \_\_\_\_\_  
*EXHIBITOR NAME*

TO: \_\_\_\_\_  
*EXHIBITOR NAME*

**C/O: FREEMAN**  
**BOSTON CONVENTION & EXHIBITION CENTI**  
**415 SUMMER ST**  
  
**BOSTON, MA 02210-1709**

**C/O: FREEMAN**  
**BOSTON CONVENTION & EXHIBITION CENTE**  
**415 SUMMER ST**  
  
**BOSTON, MA 02210-1709**

**SHOW SITE**

**SHOW SITE**

EVENT: \_\_\_\_\_ **AFP 2019**

EVENT: \_\_\_\_\_ **AFP 2019**

BOOTH NO: \_\_\_\_\_ NO. \_\_\_\_\_ OF \_\_\_\_\_ PCS

BOOTH NO: \_\_\_\_\_ NO. \_\_\_\_\_ OF \_\_\_\_\_ PCS

THE ABOVE LABELS ARE PROVIDED FOR YOUR CONVENIENCE.  
PLACE ONE ON EACH PIECE SHIPPED TO ENSURE PROPER DELIVERY.  
IF MORE LABELS ARE NEEDED, COPIES ARE ACCEPTABLE.

# WHAT ARE FREIGHT SERVICES?

As the official service contractor, Freeman is the exclusive provider of freight services. Material handling includes unloading your exhibit material, storing up to 30 days in advance at the warehouse address, delivering to the booth, the handling of empty containers to and from storage, and removing of material from the booth for reloading onto outbound carriers. It should not be confused with the cost to transport your exhibit material to and from the convention or event. You have two options for shipping your advance freight — either to the warehouse or directly to show site.

## HOW DO I SHIP TO THE WAREHOUSE?

- We will accept freight beginning 30 days prior to show move-in.
- To check on your freight arrival, call Exhibitor Services at the location listed on the Quick Facts.
- To ensure timely arrival of your materials at show site, freight should arrive by the deadline date listed on the Quick Facts. Your freight will still be received after the deadline date, but additional charges will be incurred.
- The warehouse will receive shipments Monday through Friday, except holidays. Refer to the Quick Facts for warehouse hours. No appointment is necessary.
- The warehouse will accept crates, cartons, skids, trunks/cases and carpets/pads. Loose or pad-wrapped material must be sent directly to show site.
- All shipments must have a bill of lading or delivery slip indicating the number of pieces, type of merchandise and weight.
- Shipments received without receipts or freight bills, such as Federal Express and UPS, will be delivered to the booth without guarantee of piece count or condition.
- Certified weight tickets must accompany all shipments.
- Warehouse freight will be delivered to the booth prior to exhibitor set up.

## HOW DO I SHIP TO SHOW SITE?

- Freight will be accepted only during exhibitor move-in. Please refer to the Quick Facts for the specific exhibitor move-in dates and times.
- All shipments must have a bill of lading or delivery slip indicating the number of pieces, type of merchandise and weight.
- Shipments received without receipts or freight bills, such as Federal Express and UPS, will be delivered to the booth without guarantee of piece count or condition.
- Certified weight tickets must accompany all shipments.

## WHAT ABOUT PREPAID OR COLLECT SHIPPING CHARGES?

- Collect shipments will be returned to the delivery carrier.
- To ensure that your freight does not arrive collect, mark your bill of lading “prepaid.”
- “Prepaid” designates that the transportation charges will be paid by the exhibitor or a third party.

## HOW SHOULD I LABEL MY FREIGHT?

- The label should contain the exhibiting company name, the booth number and the name of the event.
- The specific shipping address for either the warehouse or show site is located on the Quick Facts.

## HOW DO I ESTIMATE MY MATERIAL HANDLING CHARGES?

- Charges will be based on the weight of your shipment. Each shipment received is billed individually and is subject to the applicable show weight minimum. The shipment weight will be rounded to the next 100 pounds. Each 100 pounds is considered one “cwt.” (one hundred weight). All shipments are subject to reweigh.
- On the Material Handling Order Form, select whether the freight will arrive at the warehouse or be sent directly to show site.
- Next, select the rate for the freight category that best describes your shipment. There are four categories of freight:

**Crated:** material that is skidded or is in any type of shipping container that can be unloaded at the dock with no additional handling required.

**Special Handling:** material delivered by the carrier in such a manner that it requires additional handling, such as ground unloading, stacked and constricted space unloading, designated piece unloading, loads mixed with pad-wrapped material, loads failing to maintain shipping integrity, and shipments that require additional time, equipment or labor to unload. Federal Express and UPS are included in this category due to their delivery procedures.

**Uncrated:** material that is shipped loose or pad-wrapped, and/or unskidded machinery without proper lifting points.

**Carpet and/or Pad Only:** shipments that consist of loose carpet and/or padding only require additional labor and equipment to unload.

- All inbound and outbound shipments are subject to overtime charges if the shipments are received, loaded or unloaded during the overtime hours specified on the Material Handling Order Form. This includes both warehouse and show site shipments.
- Add any late delivery or off-target charges listed on the Material Handling Order Form if the freight will be received after the deadlines listed on the Quick Facts.
- The above services, whether used completely or in part, are offered as a package and the charges will be based on the total inbound weight of the shipment.

## WHAT HAPPENS TO MY EMPTY CONTAINERS DURING THE SHOW?

- Pick up “Empty Labels” at the Freeman Service Center. Once the container is completely empty, place a label on each container individually. Labeled empty containers will be picked up periodically and stored in non-accessible storage during the event.
- At the close of the show, the empty containers will be returned to the booth in random order. Depending on the size of the show, this process may take several hours.

## HOW DO I PROTECT MY MATERIALS AFTER THEY ARE DELIVERED TO THE SHOW OR BEFORE THEY ARE PICKED UP AFTER THE SHOW?

- Consistent with trade show industry practices, there may be a lapse of time between the delivery of your shipment(s) to your booth and your arrival. The same is true for the outbound phase of the show — the time between your departure and the actual pick-up of your materials. During these times, your materials will be left unattended. We recommend that you arrange for a representative to stay with your materials or that you hire security services to safeguard your materials.

## HOW DO I SHIP MY MATERIALS AFTER THE CLOSE OF THE SHOW?

- Each shipment must have a completed Material Handling Agreement in order to ship materials from the show. All pieces must be labeled individually.
- To save time, complete and submit the Outbound Shipping Form in advance, or you may contact the Freeman Service Center at show site for your shipping documents.
- Once we receive your outbound shipping information we will create your Material Handling Agreement and shipping labels. If the shipping information is provided in advance, the Material Handling Agreement will be delivered to your booth with your invoice. Otherwise the Material Handling Agreement and labels will be available for pick up at the Freeman Service Center.

- After materials are packed, labeled, and ready to be shipped, the completed Material Handling Agreement must be turned in at the Freeman Service Center.
- Call your designated carrier with pick-up information. Please refer to the Quick Facts for specific dates, times and address for pick up. In the event your selected carrier fails to show by the final move-out day, your shipment will either be rerouted on Freeman’s carrier choice or delivered back to the warehouse at the exhibitor’s expense.
- For your convenience, approved show carriers will be on site to book outbound transportation if you have not made arrangements in advance.

## WHERE DO I GET A FORKLIFT?

- Forklift orders to install or dismantle your booth after materials are delivered may be ordered in advance or at show site. We recommend that you order in advance to avoid additional charges at show site. Refer to the Rigging Order Form for available equipment.
- Advance and show site orders for equipment and labor will be dispatched once a company representative signs the labor order at the Freeman Service Center.
- Start time is guaranteed only when equipment is requested for the start of the working day.

## DO I NEED INSURANCE?

- Be sure your materials are insured from the time they leave your firm until they are returned after the show. It is suggested that exhibitors arrange all-risk coverage. This can be done by riders to your existing policies.
- All materials handled by Freeman are subject to the Terms and Conditions, which can be found in the exhibit service manual or online at [www.freeman.com](http://www.freeman.com).

## OTHER AVAILABLE FREIGHT SERVICES

(may not be available in all locations)

- Cranes
- Accessible storage at show site
- Exhibit transportation services (see enclosed brochure)
- Security storage at show site
- Short-term and long-term warehouse storage
- Local pick-up and delivery
- Priority empty return



INCLUDE THE FREEMAN METHOD OF PAYMENT FORM WITH YOUR ORDER

NAME OF SHOW: **AFP 2019 / OCTOBER 20-23, 2019**

COMPANY NAME: \_\_\_\_\_ BOOTH #: \_\_\_\_\_

CONTACT NAME: \_\_\_\_\_ PHONE #: \_\_\_\_\_

E-MAIL ADDRESS: \_\_\_\_\_

For Assistance, please call (508) 894-5100 to speak with one of our experts.

Let FreemanOnline® estimate your material handling charges for you. Log on to [www.freeman.com/store](http://www.freeman.com/store), select your show and click on "Estimate My Material Handling Costs". From FreemanOnline® you can print extra shipping labels, get tips on how to package your freight and much more.

### MATERIAL HANDLING SERVICES

- CRATED:** Material that is skidded or is in any type of shipping container that can be unloaded at the dock with no additional handling required.
- SPECIAL HANDLING:** Material delivered by a carrier in such a manner that it requires additional handling, such as ground unloading, stacked or constricted space unloading, designated piece unloading, shipment integrity, alternate delivery location, loads mixed with pad wrapped material, carpet and/or pad only shipments, no documentation and shipments that require additional time, equipment or labor to unload. **Federal Express, UPS & DHL** are included in this category due to their delivery procedures.
- UNCRATED:** Material that is shipped loose or pad-wrapped, and/or unskidded machinery without proper lifting points.
- CARPET AND/OR PAD ONLY:** Shipments that consist of loose carpet and/or padding only require additional labor and equipment to unload.
- STRAIGHT TIME:** 8:00 A.M. to 4:30 P.M. Monday through Friday
- OVERTIME:** 4:30 P.M. to 8:00 A.M. Monday through Friday, all day Saturday, Sunday, and Holidays
- NOTE: SOME INBOUND AND OUTBOUND MATERIAL HANDLING SERVICES WILL HAVE OVERTIME CHARGES**

Union Holidays: New Years Day, Martin Luther King Day, President's Day, Good Friday, Patriot's Day, Memorial Day, Independence Day, Labor Day, Columbus Day, Veteran's Day, Thanksgiving Day, Christmas Day

Description	Price Per CWT	200 lb. Minimum
<b>RATE CLASSIFICATIONS:</b>		
<b>Warehouse Shipment (200 lb. minimum)</b>		
Crated or Skidded Shipment .....	\$ 168.00	336.00
Special Handling Shipment .....	\$ 218.50	437.00
Carpet and/or Pad Only Shipment .....	\$ 252.00	504.00
<b>Show Site Shipment (200 lb. minimum)</b>		
Crated or Skidded Shipment .....	\$ 157.00	314.00
Special Handling Shipment .....	\$ 204.25	408.50
Uncrated or Pad Wrapped Shipment .....	\$ 235.50	471.00
Carpet and/or Pad Only Shipment .....	\$ 235.50	471.00
<b>Small Package - Maximum weight is 30 lbs per shipment</b>		
Per Shipment .....	\$ 45.00	

\*A small package shipment is a shipment totaling any number of pieces with a combined weight not to exceed 30 lbs that is received on the same day, from the same shipper and delivered by the same carrier.

#### ADDITIONAL SURCHARGES:

##### Shipment Delivered after Deadline Date (in addition to above rates)

Warehouse Shipment after <b>October 11</b> .....	\$ 42.00	84.00
Show site Shipment after <b>Show Opening</b> .....	\$ 39.25	78.50

All rates quoted above are straight time rates. All freight received at the warehouse that must be moved into or out of the booth before 8:00 am or after 4:30 pm on weekdays will be charged overtime rates. Show site overtime hours are before 8:00 am and after 4:30 pm on weekdays. Any time on Saturday, Sunday or holidays will be charged overtime each way in addition to the above rates.

##### Overtime Charge - Warehouse (in addition to above rates)

Crated or Skidded Shipment .....	\$ 84.00	168.00
Special Handling Shipment .....	\$ 109.25	218.50
Carpet and/or Pad Only Shipment .....	\$ 126.00	252.00

##### Overtime Charge - Show Site (in addition to above rates)

Crated or Skidded Shipment .....	\$ 78.50	157.00
Special Handling Shipment .....	\$ 102.25	204.50
Uncrated or Pad Wrapped Shipment .....	\$ 117.75	235.50
Carpet and/or Pad Only Shipment .....	\$ 117.75	235.50

##### Off-target Charge (in addition to above rates) .....

Description	Weight	CWT	Price per CWT	Estimated Total Cost (200 lb. Min.)
	÷ 100 =			
<b>Surcharges</b>	÷ 100 =			
			<b>6.25% Tax</b>	<b>N/A</b>
			<b>Total</b>	

FREEMAN material handling

# SPECIAL HANDLING DEFINITIONS

for frequently asked questions and material handling estimator tools, go to [www.freeman.com/store](http://www.freeman.com/store)

Special handling applies to shipments that are loaded by cubic space and/or packed in such a manner as to require additional labor/handling, such as ground unloading, constricted space unloading, designated piece unloading, carpet/pad only shipments or stacked shipments. Also included are shipment integrity, alternate delivery locations, mixed shipments, and shipments without individual bills of lading. Shipments loaded in this manner require additional time, labor, or equipment, to unload, sort and deliver.

## **What is Ground Loading/Unloading?**

Vehicles that are not dock height, preventing the use of loading docks, such as U-hauls, flat bed trailers, double drop trailers, company vehicles with trailers that are not dock level, etc.

## **What is Constricted Space Loading/Unloading?**

Trailer loaded "high and tight" shipments that are not easily accessible. Freight is loaded to full capacity of trailer – top to bottom, side to side. One example of this is freight that is loaded down one side of a trailer that must be bypassed to reach targeted freight.

## **What is Designated Piece Loading/Unloading?**

Drivers that require the loading crew to bring multiple pieces of the freight to the rear of the trailer to select the next piece, having to remove freight from the trailer then reload to fit or the trailer must be loaded in a sequence to ensure all items fit.

## **What are Stacked Shipments?**

Shipments loaded in such a manner requiring multiple items to be removed to ground level for delivery to booth. Stacked or "cubed out" shipments, loose items placed on top of crates and/or pallets constitute special handling.

## **What is Shipment Integrity?**

Shipment integrity involves shipments on a carrier that are intermingled, or delivered in such a manner that additional labor is needed to sort through and separate the various shipments on a truck for delivery to our customers.

## **What is Alternate Delivery Location?**

Alternative delivery location refers to shipments that are delivered by a carrier that requires us to deliver some shipments to different levels in the same building, or to other buildings in the same facility.

## **What are Mixed Shipments?**

Mixed shipments are defined as shipments of mixed crated and uncrated goods, where the percentage of uncrated is minimal and does not warrant the full uncrated rate for the shipment, but does require special handling. Freeman defines special handling for mixed loads as having less than 50% of the volume as uncrated.

## **What does it mean if I have "No Documentation"?**

Shipments arrive from a small package carrier (including, among others, Federal Express, UPS & DHL) without an individual Bill of Lading, requiring additional time, labor and equipment to process.

## **What is the difference between Crated and Uncrated Shipments?**

Crated shipments are those that are packed in any type of shipping container that can be unloaded at the dock with no additional handling required. Such containers include crates, fiber cases, cartons, and properly packed skids. An uncrated shipment is material that is shipped loose or pad-wrapped, and/or unskidded without proper lifting points.

## **What about carpet only shipments?**

Shipments that consist of loose carpet and/or padding only require additional labor and equipment to unload.

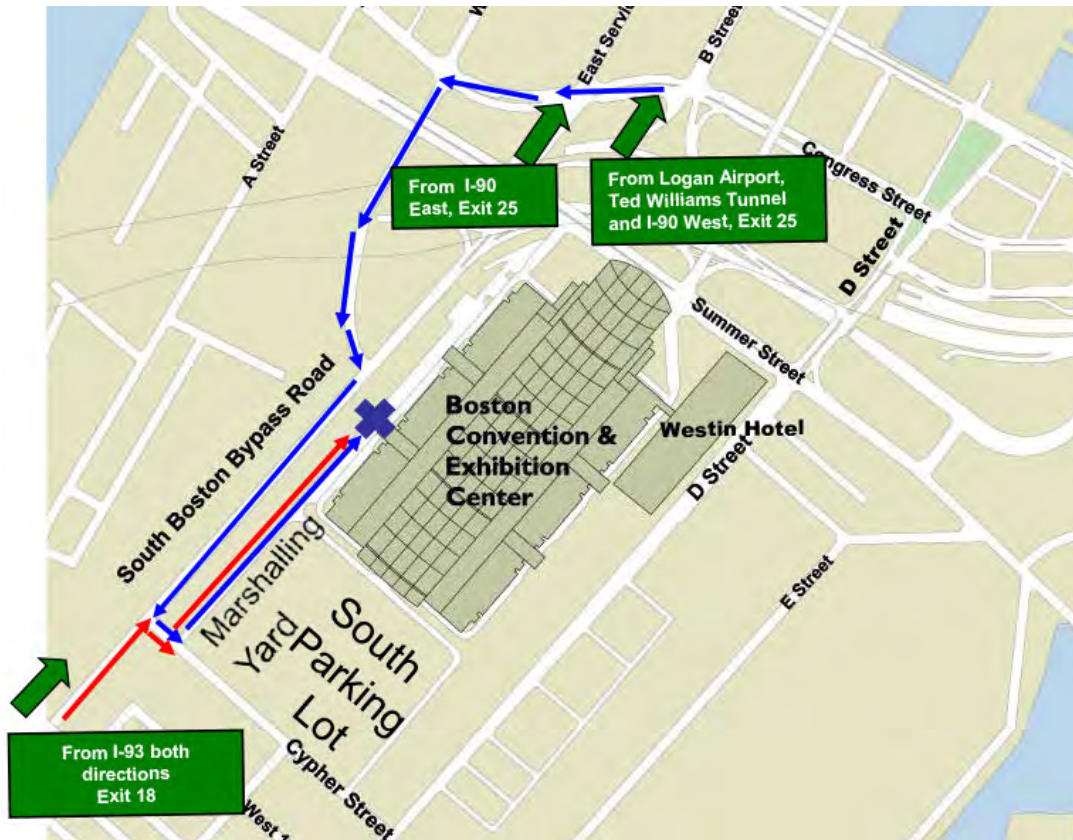

### From I-93 South:

- Take I-93 to Exit 18
- Turn left at second light onto South Boston Bypass Road
- Follow South Boston Bypass Road to Cypher Street
- Turn right on Cypher Street
- Enter BCEC Property by turning immediate left
- Marshalling yard is to the right
- Loading dock is straight ahead (check in at guard shack)

### From I-93 North:

- Take I-93 to Exit 18
- Turn right at second light onto South Boston Bypass Road
- Follow South Boston Bypass Road to Cypher Street
- Turn right on Cypher Street
- Enter BCEC Property by turning immediate left
- Marshalling yard is to the right
- Loading dock is straight ahead (check in at guard shack)

## **From I-90 East:**

- Take I-90 East to Exit 25 (inside tunnel)
- Turn left on Congress Street
- Continue one block to West Service Road
- Turn left onto West Service Road
- Proceed on West Service Road to South Boston Bypass Road
- Turn right on South Boston Bypass Road
- Continue one block to Cypher Street
- Turn left on Cypher Street
- Turn left again immediately to enter BCEC Property
- Marshalling yard is to the right
- Loading dock is straight ahead (check in at guard shack)

## **From I-90 West:**

- Take I-90 to Exit 25 (inside tunnel)
- Turn left onto Congress Street
- Continue two blocks to West Service Road
- Turn left onto West Service Road
- Proceed on West Service Road to South Boston Bypass Road
- Turn right on South Boston Bypass Road
- Continue one block to Cypher Street
- Turn left on Cypher Street
- Turn left again immediately to enter BCEC Property
- Marshalling yard is to the right
- Loading dock is straight ahead (check in at guard shack)

# Boston Convention and Exhibition Center (BCEC) Non-Commercial Vehicle Access to Loading Dock

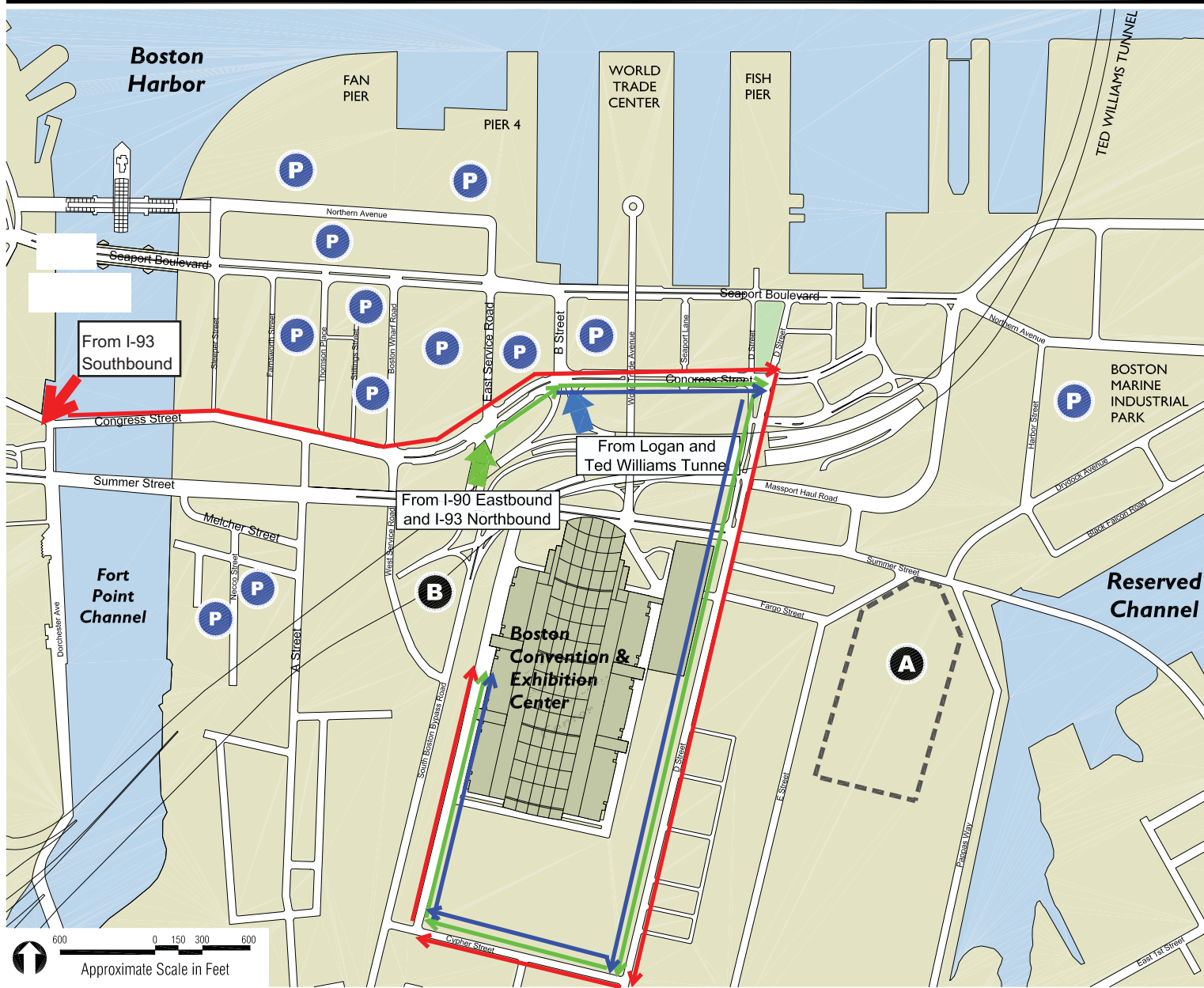

## From Logan Airport & Ted Williams Tunnel / I-90 Westbound

Take Exit 25 "South Boston" and proceed straight onto B Street. At the top of the ramp, take a right onto Congress Street. Take the next right onto D Street. At the fifth light, take a right onto Cypher Street, then the second right onto West Service Drive. The entrance to the loading dock will be directly in front of you.

## From I-90 Eastbound

Take Exit 25 "South Boston" and proceed straight onto East Service Road. At the top of the ramp, take a right onto Congress Street. Take the next right onto D Street. At the fifth light, take a right onto Cypher Street, then the second right onto West Service Drive. The entrance to the loading dock will be directly in front of you.

## From I-93 Northbound

Take Exit 20 "South Boston" and proceed straight onto East Service Road. At the top of the ramp, take a right onto Congress Street. Take the next right onto D Street. At the fifth light, take a right onto Cypher Street, then the second right onto West Service Drive. The entrance to the loading dock will be directly in front of you.

## From I-93 Southbound

Take Exit 23 "Purchase Street / South Station" and proceed straight onto Congress Street. Take a left onto Congress Street across the Fort Point Channel. Take a right onto D Street. At the fifth light, take a right onto Cypher Street, then the second right onto West Service Drive. The entrance to the loading dock will be directly in front of you.



For more information:  
[www.mccahome.com](http://www.mccahome.com)  
[www.advantageboston.com](http://www.advantageboston.com)  
 (617) 954-2100

**FREEMAN**

275 Bodwell St  
 Avon, MA 02322  
 (508) 894-5100 Fax: (469) 621-5608



OUTBOUND MATERIAL HANDLING  
 AND SHIPPING LABELS

NAME OF SHOW: **AFP 2019 / OCTOBER 20-23, 2019**

COMPANY NAME: \_\_\_\_\_ BOOTH #: \_\_\_\_\_ BOOTH SIZE: \_\_\_\_\_ X

CONTACT NAME : \_\_\_\_\_ PHONE #: \_\_\_\_\_

E-MAIL ADDRESS : \_\_\_\_\_

For Assistance, please call (508) 894-5100 to speak with one of our experts.

**For fast, easy ordering, go to [www.freeman.com](http://www.freeman.com)**

**EVERY OUTBOUND SHIPMENT WILL REQUIRE A MATERIAL HANDLING AGREEMENT AND SHIPPING LABELS. WE WOULD BE HAPPY TO PREPARE THESE FOR YOU AND DELIVER THEM TO YOUR BOOTH PRIOR TO SHOW CLOSE. TO TAKE ADVANTAGE OF THIS SERVICE, PLEASE COMPLETE AND RETURN THIS FORM TO THE FREEMAN SERVICE CENTER.**

**SHIPPING INFORMATION**

SHIP TO: COMPANY NAME: \_\_\_\_\_

DELIVERY ADDRESS: \_\_\_\_\_

CITY: \_\_\_\_\_ STATE/ PROVINCE: \_\_\_\_\_ ZIP/ POSTAL CODE: \_\_\_\_\_

PHONE#: \_\_\_\_\_ ATTN: \_\_\_\_\_

SPECIAL INSTRUCTIONS: \_\_\_\_\_

**BILL TO:**  Same as Ship to:

COMPANY NAME: \_\_\_\_\_

DELIVERY ADDRESS: \_\_\_\_\_

CITY: \_\_\_\_\_ STATE/ PROVINCE: \_\_\_\_\_ ZIP/ POSTAL CODE: \_\_\_\_\_

**METHOD OF SHIPMENT**

**Select a Carrier:**

- Freeman Exhibit Transportation**       **Other Carrier**

No need to schedule your outbound shipment.  
 Charges will appear on your Freeman invoice.

Carrier Name: \_\_\_\_\_  
 Carrier Phone: \_\_\_\_\_

Freeman will make arrangements for all Freeman Exhibit Transportation shipments.  
 Arrangements for pick-up by other carriers is the responsibility of the exhibitor.

**Select a Level of Service:**

- 1 Day: Delivery next business day       Standard Ground  
 2 Day: Delivery by 5:00 PM second business day       Specialized: Pad wrapped, uncrated, or truckload  
 Deferred: Delivery within 3-5 business days

**Select Shipment Options (if applicable)**

- Have loading dock       Lift gate required  
 Inside delivery       Air ride required  
 Pad wrap required       Residential  
 Do not stack

**Select Desired Number of Labels:** \_\_\_\_\_

Once your shipment is packed and ready to be picked up from your booth, please return completed the Material Handling Agreement to the Freeman Service Center. Shipments without a Material Handling Agreement turned in will be returned to our warehouse at exhibitor's expense.

## **SECTION XII**

### **IAEE GUIDELINES & RESTRICTIONS**



# Guidelines for Display Rules & Regulations

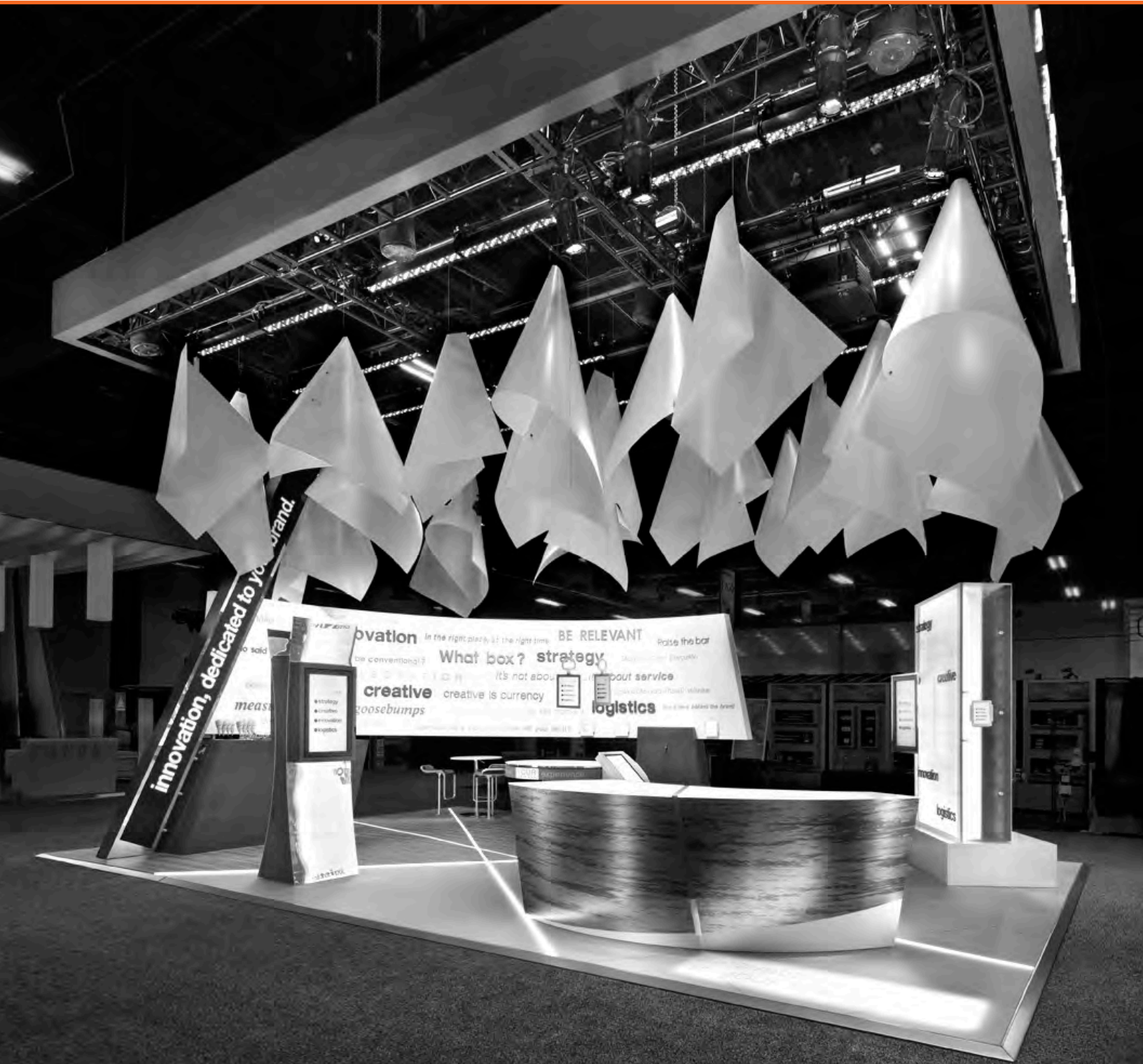

# Contents

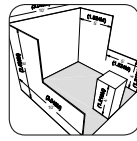

Linear Booth and Corner Booth

4

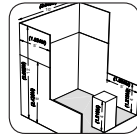

Perimeter Booth

5

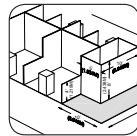

End-cap Booth

6

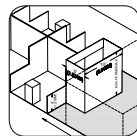

Peninsula Booth

7

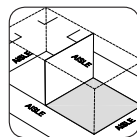

Split Island Booth

8

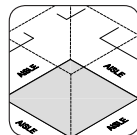

Island Booth

9

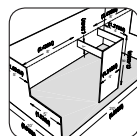

Extended Header Booth

10

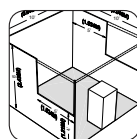

Other Important Considerations

11

Issues Common To All Booth Types

12-14

Advisory Notes To Exhibition Organizers

15-16

## Guidelines for Display Rules and Regulations 2014 Update

The following *Guidelines for Display Rules and Regulations* have been established by the International Association of Exhibitions and Events™ (IAEE). *Guidelines for Display Rules and Regulations* are created to promote continuity and consistency among North American exhibitions and events. They are the model for most domestic exhibitions and events. It is recommended that exhibition organizers include a copy in the Exhibition Prospectus and/or Exhibitor Rules and Regulations.

This revised 2014 edition of IAEE's *Guidelines for Display Rules and Regulations* is offered as a resource for exhibitions and events organizers to use in creating consistent and fair exhibiting standards for their events. These *Guidelines* afford exhibitors a maximum return on their exhibit investments. Compliance with fire, safety, Americans with Disabilities Act (ADA), and other state, federal or provincial government requirements has also been addressed. However, always check with a local exhibition service contractor and the facility for local regulations.

It is IAEE's goal that the display rules and regulations, ultimately developed by each exhibitions and events organizer, shall provide exhibitors with all the information necessary to properly design and build exhibits, as well as plan their booth's layout and content. Show organizers should present the professional standards expected of exhibitors. Finally, they should assure all exhibitors, regardless of exhibit size or location, an environment conducive to successful interaction with their audiences.

IAEE is a global association that serves as the foremost authority on exhibitions and events management and operations.

---

**For display rules and regulations specific to an exhibition or event,  
consult the exhibition or event organizer.**

# Linear Booth

Linear Booths, also called “in-line” booths, are generally arranged in a straight line and have neighboring exhibitors on their immediate right and left, leaving only one side exposed to the aisle.

## Dimensions

For purposes of consistency and ease of layout and/or reconfiguration, floor plan design in increments of 10ft (3.05m) has become the de facto standard in the United States. Therefore, unless constricted by space or other limitations, Linear Booths are most commonly 10ft (3.05m) wide and 10ft (3.05m) deep, i.e. 10ft by 10ft (3.05m by 3.05m). A maximum back wall height limitation of 8ft (2.44m) is generally specified.

## Use of Space

Regardless of the number of Linear Booths utilized, e.g. 10ft by 20ft (3.05m by 6.10m), 10ft by 30ft (3.05m by 9.14m), 10ft by 40ft (3.05m by 12.19m), etc. display materials should be arranged in such a manner so as not to obstruct sight lines of neighboring exhibitors. The maximum height of 8ft (2.44m) is allowed only in the rear half of the booth space, with a 4ft (1.22m) height restriction imposed on all materials in the remaining space forward to the aisle. (See Line-of-Sight exception on page 8.) Note: When three or more Linear Booths are used in combination as a single exhibit space, the 4ft (1.22m) height limitation is applied only to that portion of exhibit space which is within 10ft (3.05m) of an adjoining booth.

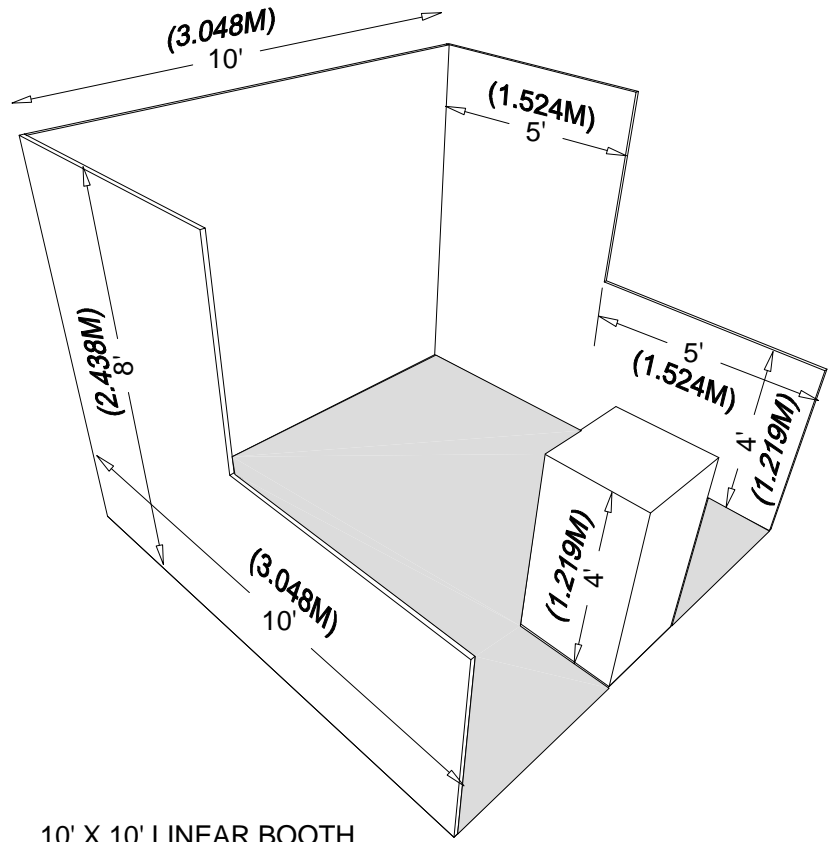
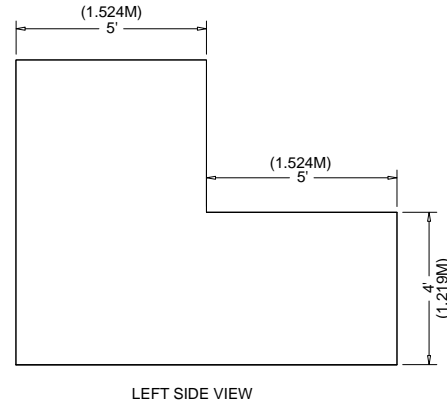
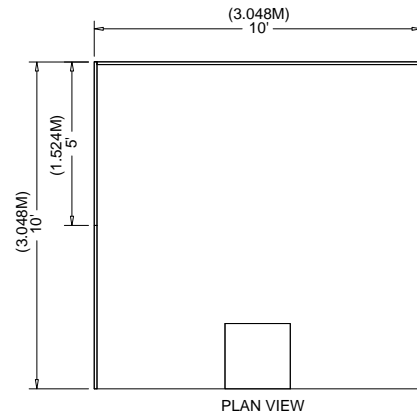

10' X 10' LINEAR BOOTH

# Corner Booth

A Corner Booth is a Linear Booth at the end of a series of in-line booths with exposure to intersecting aisles on two sides. All other guidelines for Linear Booths apply.

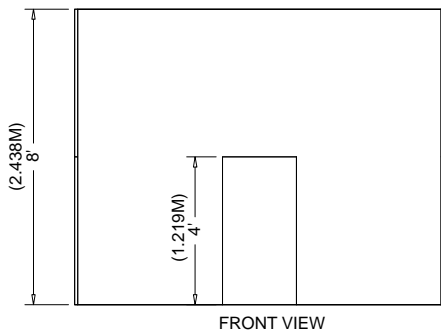

FRONT VIEW

# Perimeter Booth

A Perimeter Booth is a Linear Booth that backs to an outside wall of the exhibit facility rather than to another exhibit.

## Dimensions and Use of Space

All guidelines for Linear Booths apply to Perimeter Booths except that the typical maximum back wall height is 12ft (3.66m).

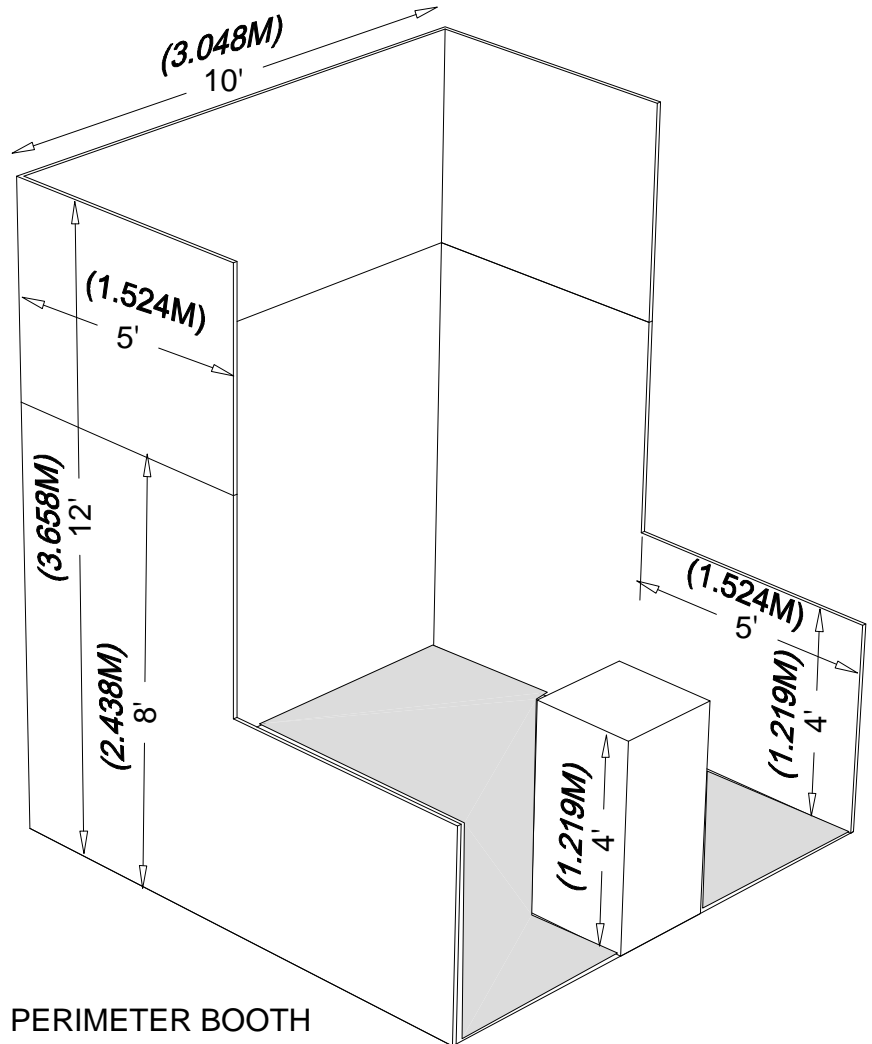
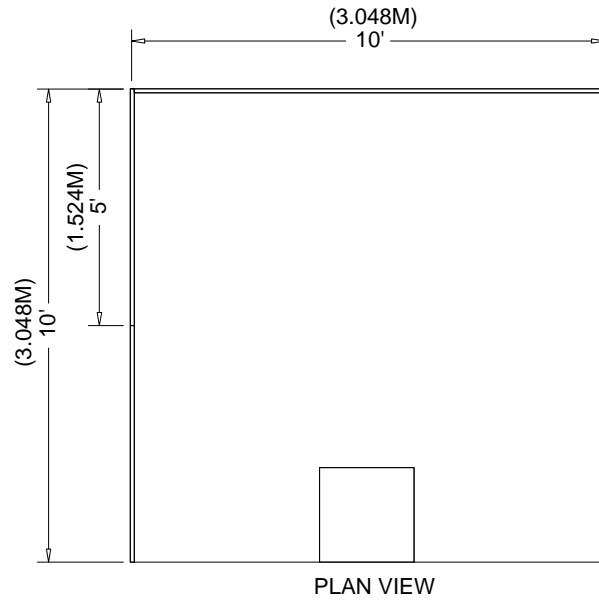
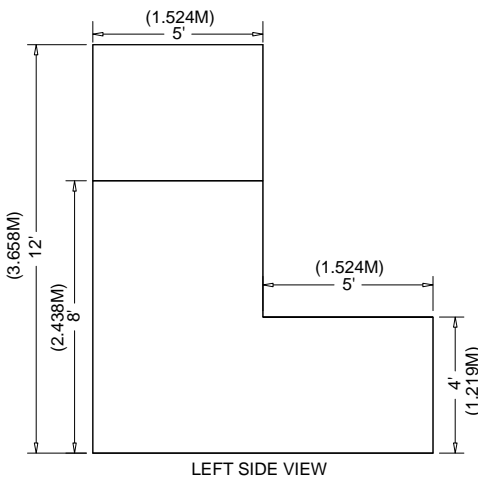
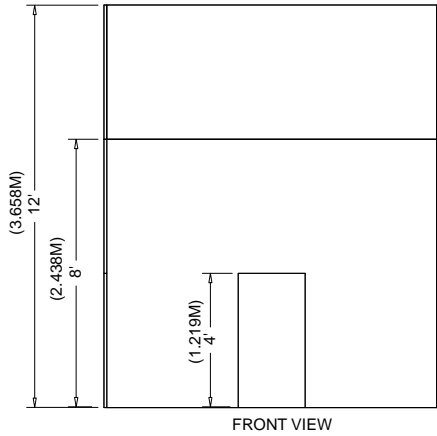

# End-cap Booth

An End-cap configuration is essentially an in-line (linear) booth placed in the position of a Peninsula or Split Island. For shows that have Line-of-Sight rules and not cubic content, this configuration must follow the dimensions below. For shows that have cubic content rules, the space may be used without restriction.

## Dimensions

End-cap Booths are generally 10ft (3.05m) deep by 20ft (6.10m) wide. The maximum back wall height allowed is 8ft (2.44m) and the maximum back-wall width allowed is 10ft (3.05m) at the center of the back-wall with a maximum 5ft (1.52m) height on the two side aisles. Within 5' of the 2 side aisles, the maximum height for any display materials is 4'.

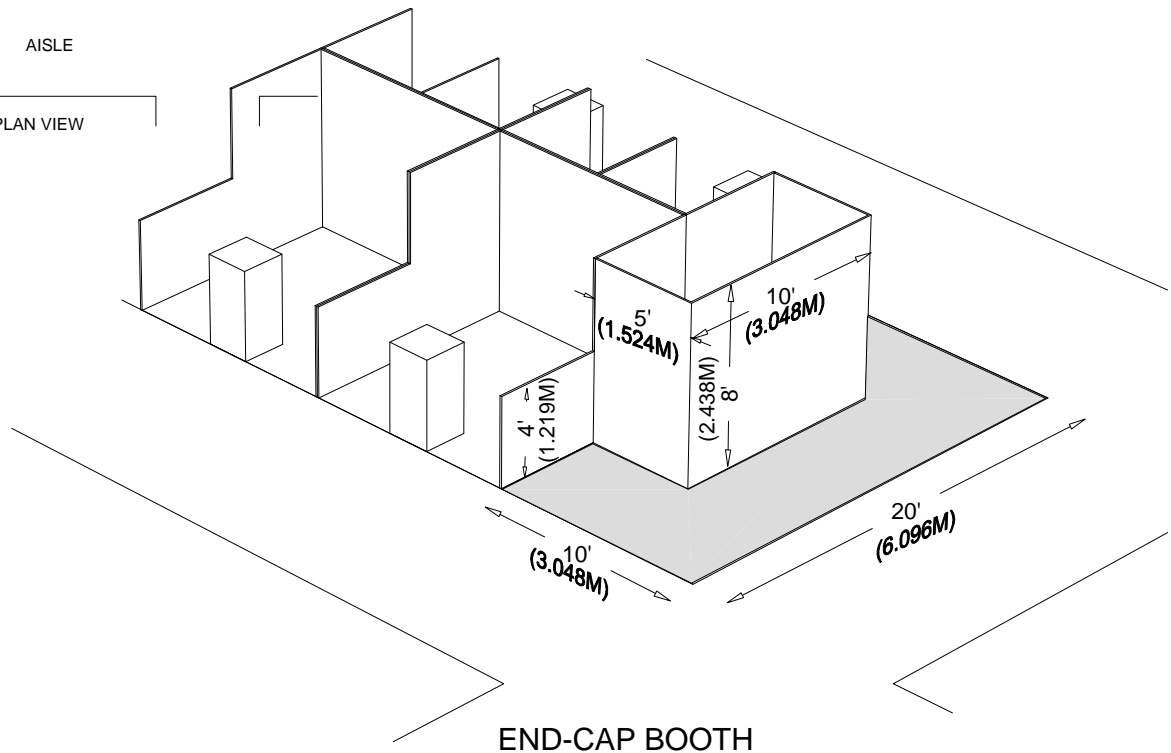
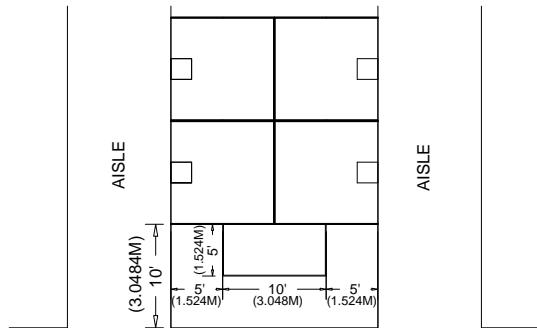
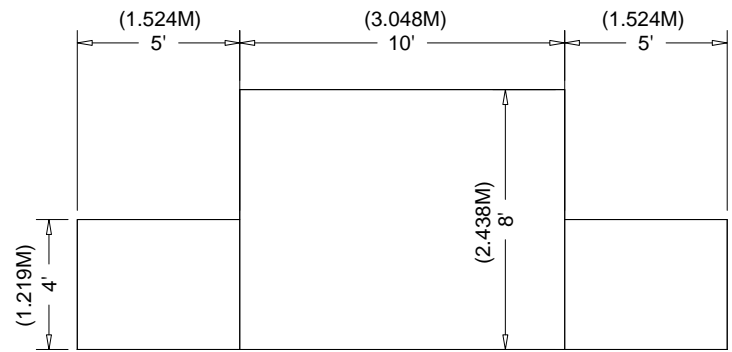
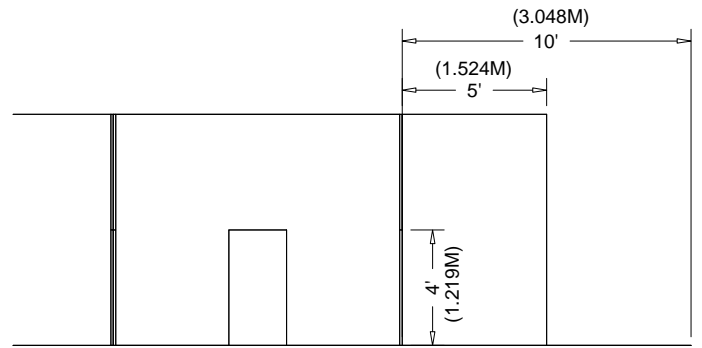

# Peninsula Booth

A Peninsula Booth is exposed to aisles on three sides, and comprised of a minimum of four booths. There are two types of Peninsula Booths: (a) one which backs to Linear Booths, and (b) one which backs to another Peninsula Booth and is referred to as a “Split Island Booth.”

## Dimensions

A Peninsula Booth is usually 20ft by 20ft (6.10m by 6.10m) or larger. When a Peninsula Booth backs up to two Linear Booths, the back wall is restricted to 4ft (1.22m) high within 5ft (1.52m) of each aisle, permitting adequate line of sight for the adjoining Linear Booths. (See Line-of-Sight exception on page 8.) A typical maximum height range allowance is 16ft to 20ft (4.88m to 6.10m), including signage for the center portion of the back wall. Double-sided signs, logos and graphics shall be set back ten feet (10') (3.05m) from adjacent booths.

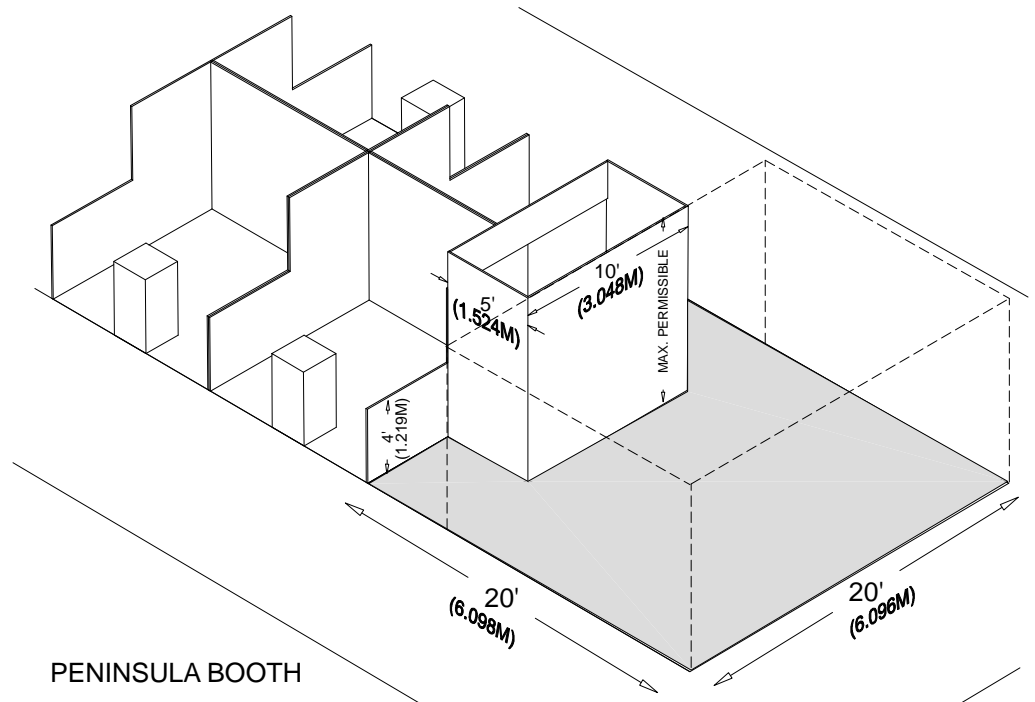
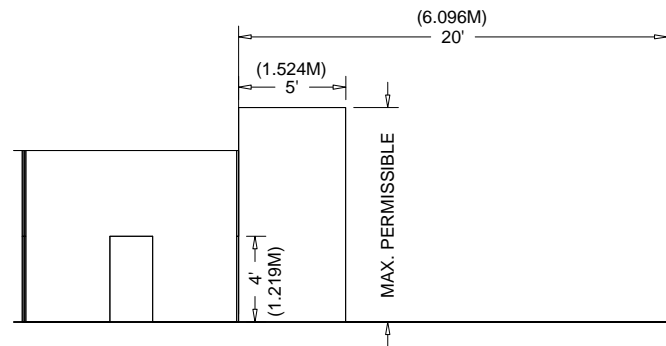
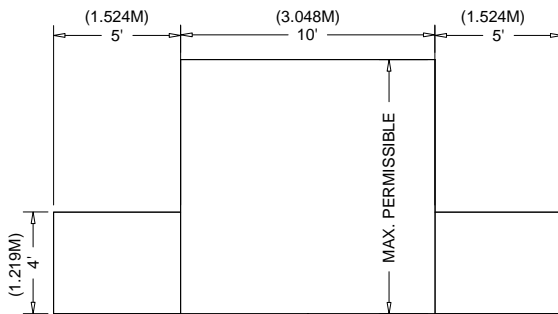
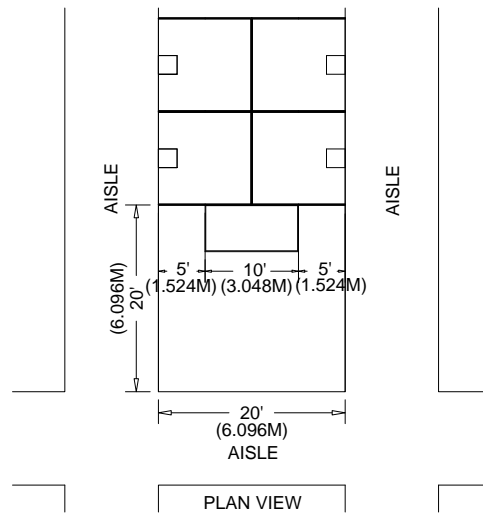

# Split Island Booth

A Split Island Booth is a Peninsula Booth which shares a common back wall with another Peninsula Booth. The entire cubic content of this booth may be used, up to the maximum allowable height, without any back wall Line-of-Sight restrictions. A typical maximum height range allowance is 16ft to 20ft (4.88m to 6.10m), including signage. The entire cubic content of the space may be used up to the maximum allowable height. Double-sided signs, logos and graphics shall be set back ten feet (10') (3.05m) from adjacent booths.

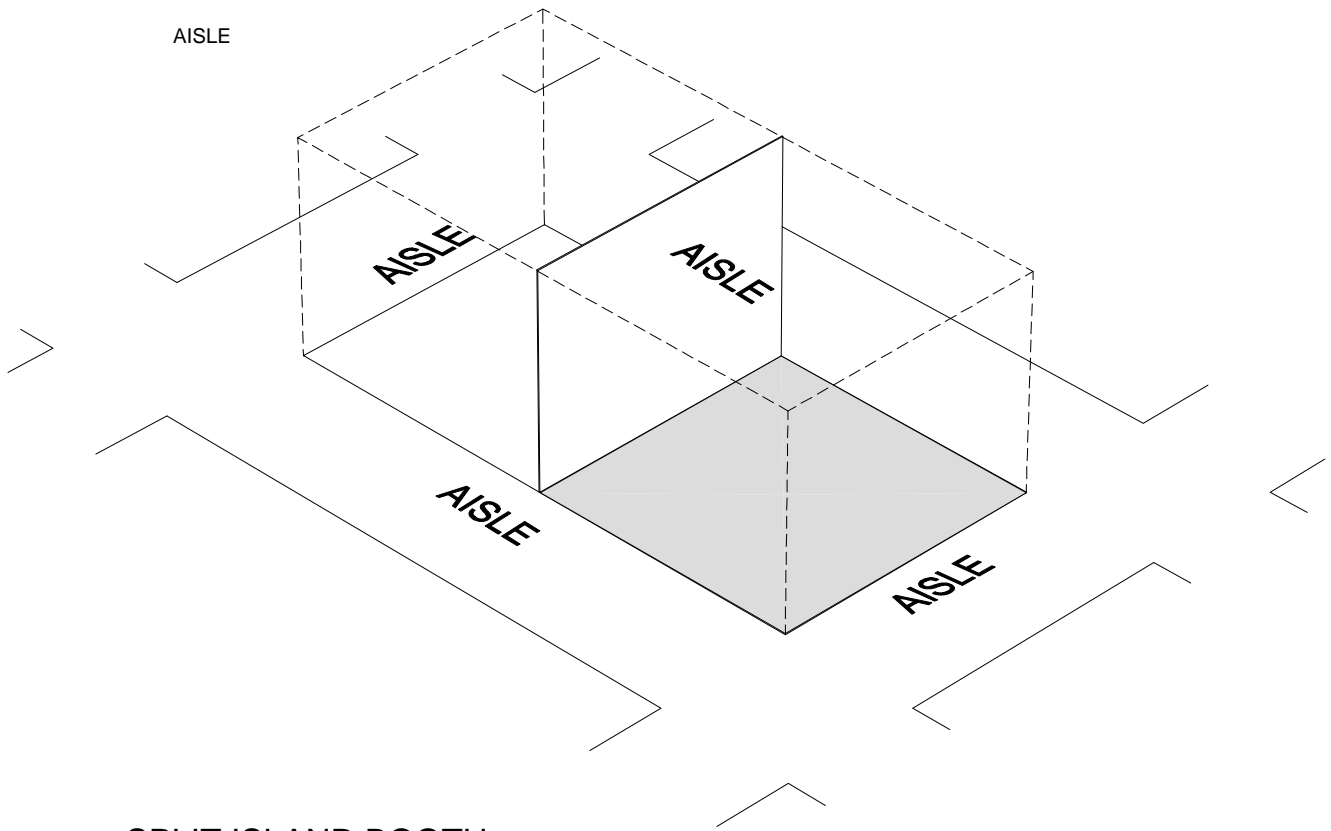
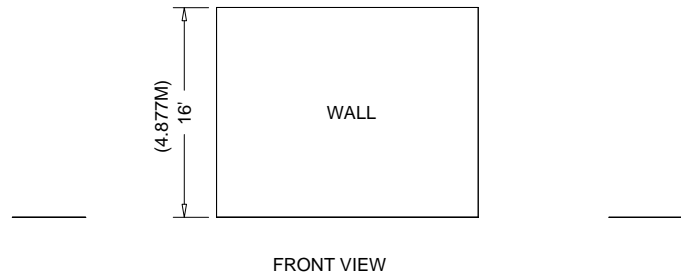
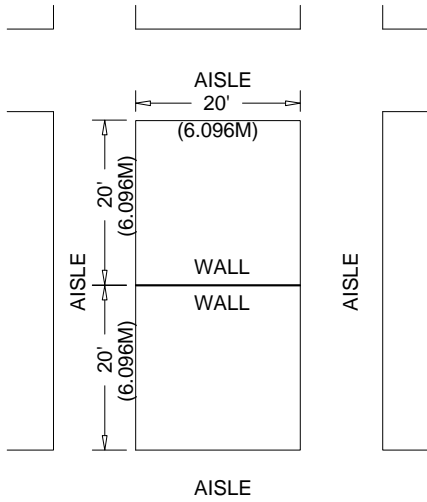
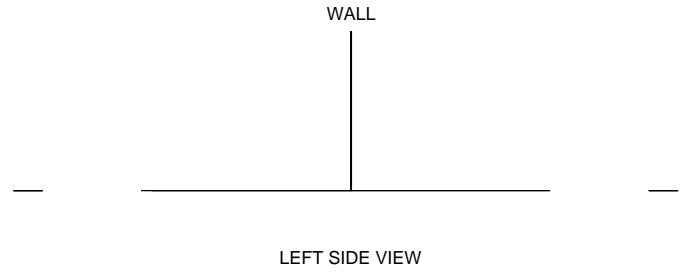

SPLIT ISLAND BOOTH

# Island Booth

An Island Booth is any size booth exposed to aisles on all four sides.

## Dimensions

An Island Booth is typically 20ft by 20ft (6.10m by 6.10m) or larger, although it may be configured differently.

## Use of Space

The entire cubic content of the space may be used up to the maximum allowable height, which is usually a range of 16ft to 20ft (4.88m to 6.10m), including signage.

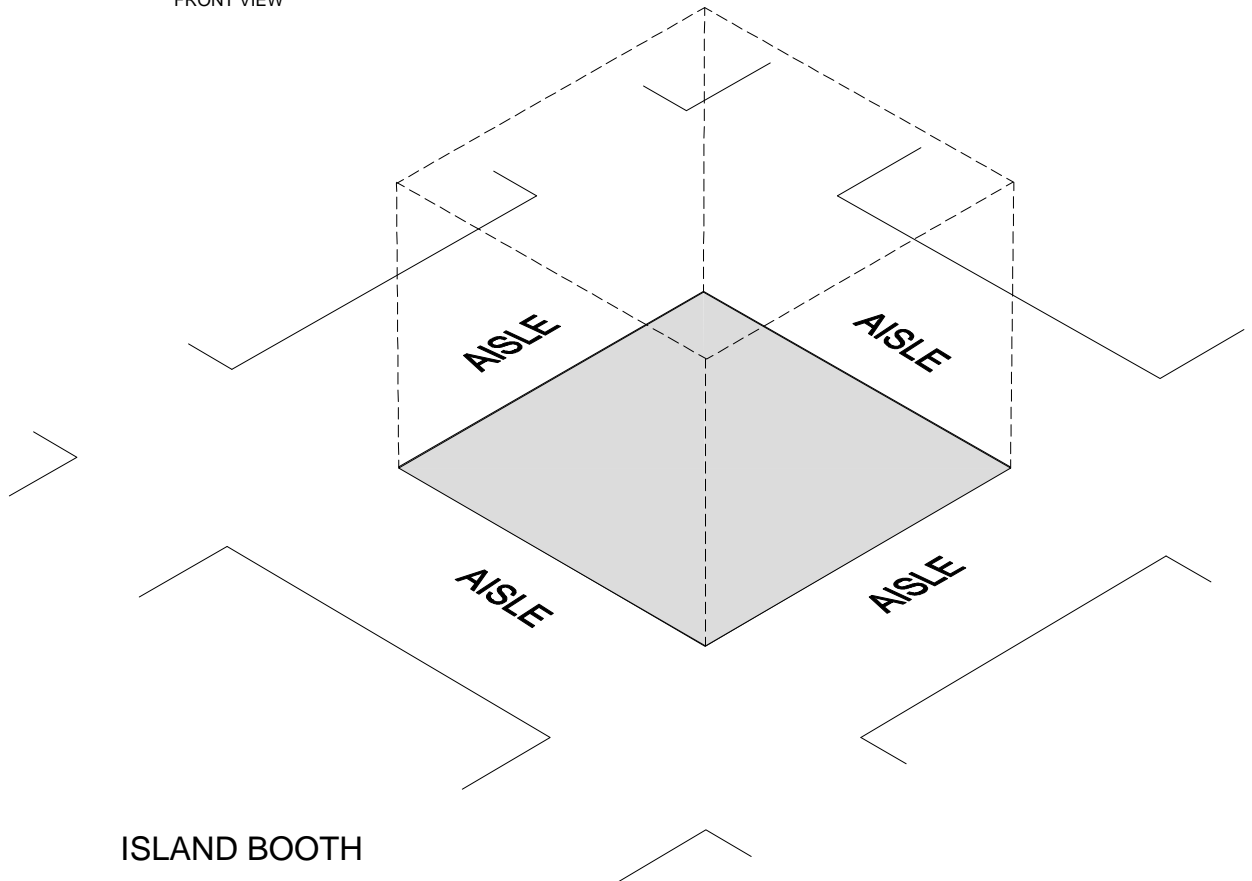
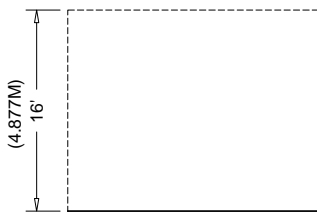
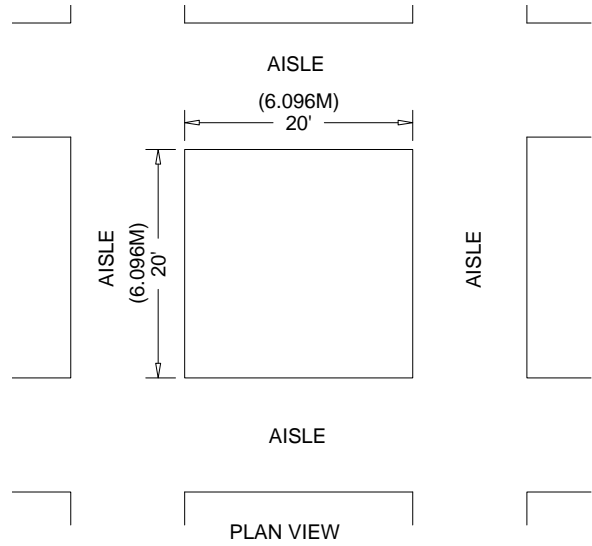

# Extended Header Booth 20ft (6.10m) or Longer

An Extended Header Booth is a Linear Booth 20ft (6.10m) or longer with a center extended header.

## Dimensions and Use of Space

All guidelines for Linear Booths apply to Extended Header Booths, except that the center extended header has a maximum height of 8ft (2.44m), a maximum width of 20 percent of the length of the booth, and a maximum depth of 9ft (2.7m) from the back wall.

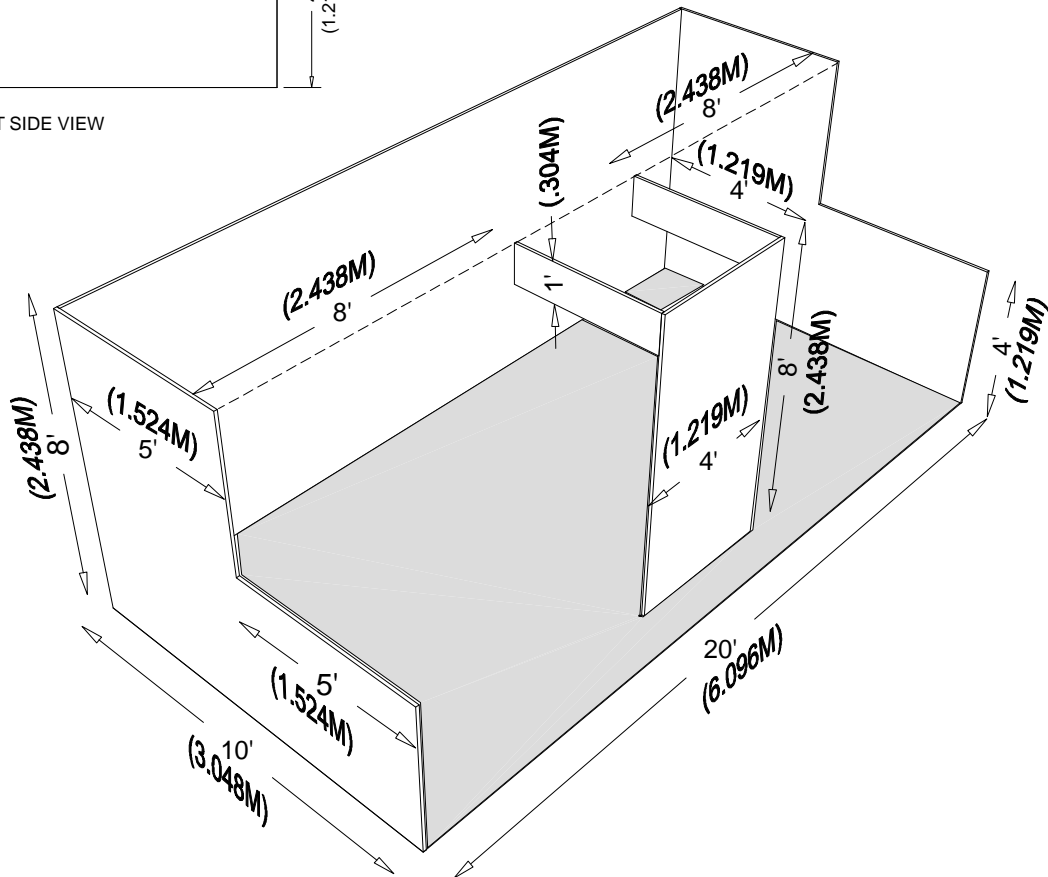
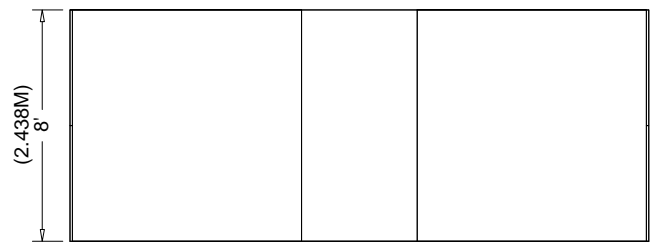
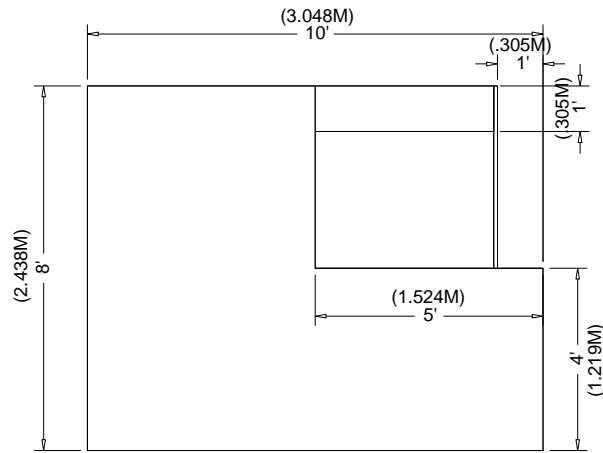
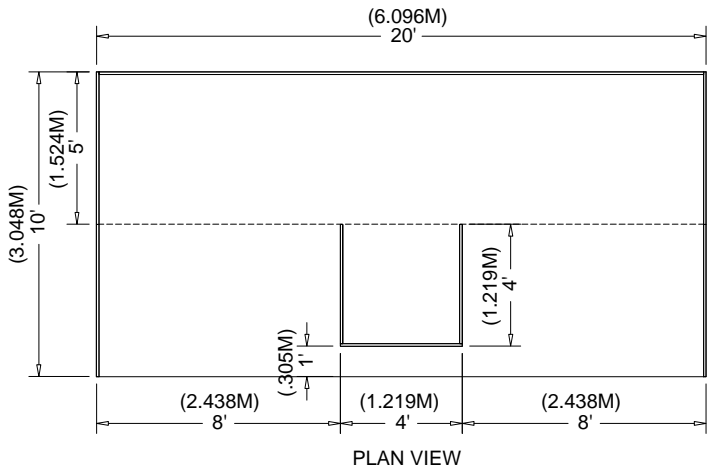

10' X 20' EXTENDED HEADER BOOTH

## Other Important Considerations

### Canopies and Ceilings

Canopies, including ceilings, umbrellas and canopy frames, can be either decorative or functional (such as to shade computer monitors from ambient light or to allow for hanging products). Canopies for Linear or Perimeter Booths should comply with Line-of-Sight requirements. (See “Use of Space” for Linear or Perimeter Booths).

The bottom of the canopy should not be lower than 7ft (2.13m) from the floor within 5ft (1.52m) of any aisle. Canopy supports should be no wider than three inches 3in (.08m). This applies to any booth configuration that has a sight line restriction, such as a Linear Booth. Fire and safety regulations in many facilities strictly govern the use of canopies, ceilings and other similar coverings. Check with the appropriate local agencies prior to determining specific exhibition rules.

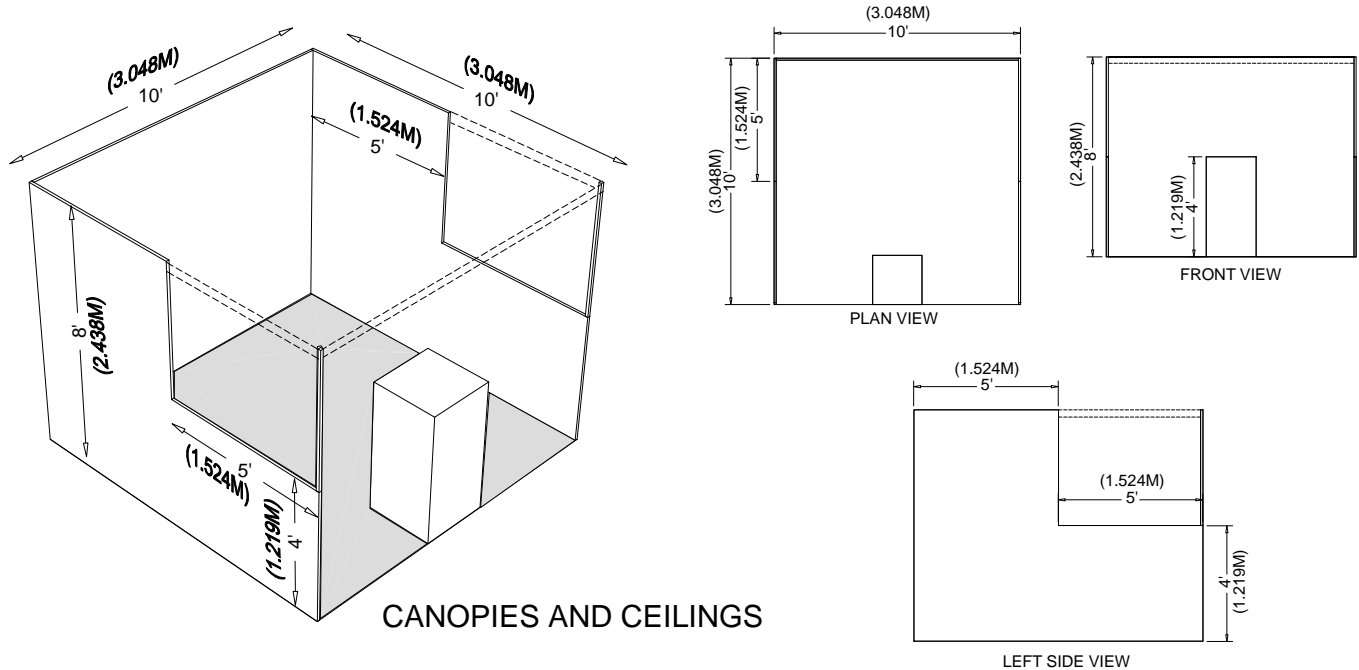

### Hanging Signs & Graphics

Most exhibitions and events rules allow for Hanging Signs and Graphics in all standard Peninsula and Island Booths, usually to a maximum height range of 16ft to 20ft (4.88m to 6.10m) from the top of the sign, or as determined by the show organizer. End-cap Booths do not qualify for Hanging Signs and Graphics. The distance is measured from the floor to the top of the sign. Whether suspended from above, or supported from below, they should comply with all ordinary use-of-space requirements. For example, the highest point of any sign should not exceed the maximum allowable height for the booth type.

Hanging Signs and Graphics should be set back 10ft (3.05m) from adjacent booths and be directly over contracted space only.

Approval for the use of Hanging Signs and Graphics, at any height, should be received from the exhibitions or events organizer at least 60 days prior to installation. Variances may be issued at the exhibitions or events management’s discretion. Drawings should be available for inspection.

### Towers

A Tower is a free-standing exhibit component separate from the main exhibit fixture. The height restriction is the same as that which applies to the appropriate exhibit space configuration being used.

Towers in excess of 8ft (2.44m) should have drawings available for inspection. Fire and safety regulations in many facilities strictly govern the use of Towers. A building permit or safety lines may be required.

### Multi-story Exhibit

A Multi-story Exhibit is a booth where the display fixture includes two or more levels. In many cities, a Multi-story Exhibit requires prior approval by the exhibit facility, and/or relevant local government agency, as well as show management because it is deemed to be a “structure” for building purposes. The city building department generally needs to issue a building permit based on an application and drawings prepared and submitted by a licensed architect or engineer. Exhibitors should obtain local building regulations early on to ensure that all time constraints are met. Exhibitions and events organizers should be prepared to assist exhibitors in this application process.

# Issues Common To All Booth Types

## Americans with Disabilities Act (ADA)

All exhibiting companies are required to be in compliance with the Americans with Disabilities Act (ADA), and are encouraged to be sensitive, and as reasonably accommodating as possible, to attendees with disabilities. Information regarding ADA compliance is available from the U.S. Department of Justice ADA Information Line (800) 514-0301, and from the ADA website at [www.ada.gov](http://www.ada.gov). Some examples of how to design an exhibit for ADA compliance:

- Make exhibits wheelchair accessible by ramping raised exhibit flooring without extending a ramp into the aisle. Note: a standard wheelchair ramp should have a grade no steeper than 1:12. This means that for every inch of rise (change in height), there should be 12 inches of run (change in length)
- Ramp the entry or use hydraulic lifts to trailer exhibits
- Avoid double-padded plush carpet to ease mobility device navigation
- Provide the same attendee experience on both levels of a two-story exhibit
- Offer a signer or other auxiliary hearing-impaired apparatus for sound presentations or have a printed copy of the presentation available
- Run an audio presentation for people with sight problems
- Arrange touch screen displays at a height to accommodate a person sitting in a wheelchair

To avoid heavy fines by the U. S. Department of Justice, exhibitors must adhere to the ADA rules. Exhibits are not exempt from ADA compliance.

## Structural Integrity

All exhibit displays should be designed and erected in a manner that will withstand normal contact or vibration caused by neighboring exhibitors, hall laborers, or installation/dismantling equipment, such as fork lifts. Displays should also be able to withstand moderate wind effects that may occur in the exhibit hall when freight doors are open. Refer to local building codes that regulate temporary structures.

It is recommended that all 20ft by 20ft (6.10m by 6.10m) and over exhibits require a drawing, plans or renderings, preferably digital, to be submitted to the show organizer, and to the show's general service contractor.

Exhibitors should ensure that any display fixtures such as tables, racks, or shelves are designed and installed properly to support the product or marketing materials to be displayed.

## Flammable and Toxic Materials

All materials used in display construction or decorating should be made of fire retardant materials and be certified as flame retardant. Samples should also be available for testing. Materials that cannot be treated to meet the requirements should not be used. A flame-proofing certificate should be available for inspection. Exhibitors should be aware of local regulations regarding fire/safety and environment which must be adhered to.

Exhibitors should dispose of any waste products they generate during the exhibition in accordance with guidelines established by the Environmental Protection Agency and the facility.

## Storage

Fire regulations in most exhibit facilities prohibit storing product, literature, empty packing containers, or packing materials behind back drapes or under draped tables. In most cases, however, exhibitors may store a limited supply of literature or product appropriately within the booth area, so long as these items do not impede access to utility services, create a safety problem, or look unsightly.

## Issues Common To All Booth Types *(continued)*

### Electrical

Every exhibit facility has different electrical requirements. However, minimum guidelines are suggested:

- All 110-volt wiring should be grounded three-wire.
- Wiring that touches the floor should be “SO” cord (minimum 14-gauge/three-wire) flat cord, which is insulated to qualify for “extra hard usage.”
- Cord wiring above floor level can be “SJ” which is rated for “hard usage.”
- Using zip cords, two-wire cords, latex cords, plastic cords, lamp cords, open clip sockets, and two-wire clamp-on fixtures is not recommended and is often prohibited. Cube taps should be prohibited.
- Power strips (multi-plug connectors) should be UL approved, with built-in over-load surge protectors.

### Lighting

Exhibitors should adhere to the following suggested minimum guidelines when determining booth lighting:

- No lighting, fixtures, lighting trusses, or overhead lighting are allowed outside the boundaries of the exhibit space. Exhibitors intending to use hanging light systems should submit drawings to exhibition management for approval.
- Lighting, including gobos, should be directed to the inner confines of the booth space. Lighting should not project onto other exhibits or exhibition aisles.
- Lighting that is potentially harmful, such as lasers, ultraviolet lights or flashing or strobe lights that can trigger photosensitive epilepsy should comply with facility rules and be approved in writing by exhibition management.
- Lighting that spins, rotates, pulsates, and other specialized lighting effects should be in good taste and not interfere with neighboring exhibitors or otherwise detract from the general atmosphere of the event.
- LED lights can be very bright yet generally generate less heat.
- Currently, some convention facilities are not allowing certain types of quartz halogen lighting fixtures in exhibits due to potential fire hazards. Check with exhibition management.
- Reduced lighting for theater areas should be approved by the exhibition organizer, the utility provider, and the exhibit facility.

### Demonstrations

As a matter of safety and courtesy to others, exhibitors should conduct sales presentations and product demonstrations in a manner which assures all exhibitor personnel and attendees are within the contracted exhibit space and not encroaching on the aisle or neighboring exhibits. It is the responsibility of each exhibitor to arrange displays, product presentation, audio visual presentations, and demonstration areas to ensure compliance. Exhibitors should be aware of local regulations regarding fire/safety and environment which must be adhered to.

Special caution should be taken when demonstrating machinery or equipment that has moving parts, cooking equipment with an open flame, or any product that is otherwise potentially dangerous. Exhibitors should establish a minimum setback of 3ft (.91m) and/or install hazard barriers as necessary to prevent accidental injury to spectators. Additionally, demonstrations should only be conducted by qualified personnel.

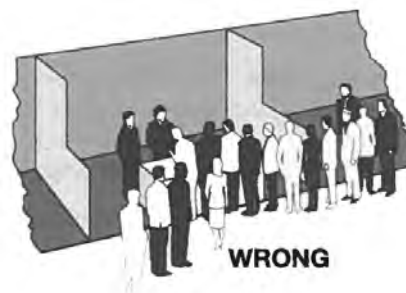
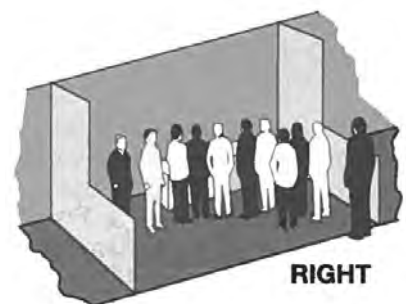

## Issues Common To All Booth Types *(continued)*

### **Sound/Music**

In general, exhibitors may use sound equipment in their booths so long as the noise level does not disrupt the activities of neighboring exhibitors. Speakers and other sound devices should be positioned so as to direct sound into the booth rather than into the aisle. Rule of thumb: Sound and noise should not exceed 85 decibels when measured from the aisle immediately in front of a booth. (Refer to OSHA at [www.osha.gov](http://www.osha.gov) for more information.)

Exhibitors should be aware that music played in their booths, whether live or recorded, may be subject to laws governing the use of copyrighted compositions. ASCAP, BMI, and SESAC are three authorized licensing organizations that collect copyright fees on behalf of composers and publishers of music.

### **Vehicles**

**Vehicles:** Rules vary depending on the facility, but generally it is required that vehicles on display have no more than one fourth tank of gas. The filler cap should be sealed and the batteries disconnected. External chargers are usually recommended for demonstration purposes. Keys should always be surrendered to show management while participating in an exhibition or event.

## Advisory Notes To Exhibition Organizers

**End-cap Booths:** End-cap Booths cause more problems between exhibitors than any other type of booth, because most exhibitors fail to observe back wall height restrictions. Exhibition managers should be alert to exhibitors reserving End-cap configurations to ensure they do not violate Linear Booth Line-of-Sight regulations for neighboring exhibits.

**Fire Equipment:** Fire hoses, extinguishers, and audible or visual devices for fire alarms should be visible and accessible at all times.

**Hanging Signs:** Although these *Guidelines* indicate 16ft to 20ft (4.88m to 6.10m) as a maximum height range from the top of the sign, some exhibitions permit other heights, or have no height limit. Caution should be exercised so exhibitors will not compete over air space for Hanging Signs. Most show organizers limit the height of signs.

Exhibitors should be advised to install “hanging points” at the time of manufacture of the sign or display. It is also advisable to have Hanging Signs labeled and cased separately so that they can be easily identified on-site as they usually must be installed before other exhibit construction can begin.

**Hardwall Booths:** Exhibitions that provide Hardwall Booths should specify if these structures can be used for display and attaching products.

**Full Cubic Content in Linear Space:** It is the responsibility of the exhibitions or events organizer to establish rules to best achieve the goals for their exhibition or event based on the nature of their exhibition and event, and industry sector it serves.

**Cubic Content Definition:** Using the perimeter lines of a booth as a guide, the exhibitor may install a booth up to these lines and utilize all the volume of space within these lines up to the maximum height permitted by the show rules as determined by the show organizer.

It is the choice of the exhibitions or events organizer to allow use of full Cubic Content in linear exhibit space or to observe the Line-of-Sight set-back rule. It is common at certain types of exhibitions or events to eliminate the Line-of-Sight requirement for Linear, End-cap, and Peninsula Booths that back up to Linear Booths. This permits exhibitors to utilize the full Cubic Content of the booth.

Organizers that permit use of Cubic Content in Linear Booths do so for one or all of these reasons:

- Cubic Content is more conducive to certain types of product displays or experiences.
- Cubic Content maximizes the exhibit space and investment.
- International exhibitions generally utilize Cubic Content making the show friendlier to international exhibitors.
- Cubic Content reduces the need to police exhibits to enforce setback rules.

Use of Cubic Content may create situations where the organizer must address exhibits that have unfinished walls. A determination must be made as to responsibility for finishing these unfinished walls.

It is prudent for the exhibitions or events organizer considering Cubic Content to examine the concerns, advantages and disadvantages prior to putting Cubic Content guidelines into practice. It is often wise to consult with the exhibition’s Exhibits Advisory Board or perhaps conduct a focus group of the exhibition’s or event’s exhibitors to determine their interest and gain their feedback and support for the concept. Exhibitions and events organizers must be proactive in communicating with exhibitors and understanding the effect it will have on the exhibition or event.

To learn more about Full Cubic Content, read the IAEE White Paper: **Evaluating and Implementing Cubic Content into Linear Exhibit Space.**

## Advisory Notes To Exhibition Organizers *(continued)*

**Perimeter Openings:** Large Peninsulas and Islands with long high walls can create a “tunnel-like” effect. Exhibitors may be required to install a minimum 6ft (1.83m) opening every 30ft (9.14m).

**Pipe and Drape:** These are commonly used at exhibitions and events in the United States to define exhibit space. Exhibitions and events organizers often include in their rules and regulations that this equipment is not intended as a display fixture. Therefore, product and signs should not be attached or affixed. Measurements of booths must allow for size of pipe on sides and back.

**Product Height:** Some exhibitors have products that exceed display height restrictions. Exhibitions and events organizers should establish guidelines for displaying such products. For example, some exhibitions or events require that these exhibitors reserve only perimeter space. Products exceeding height restrictions for Islands and Peninsulas are usually permitted, providing they are displayed in operating mode, and the names and logos, etc. on the product are as it is sold.

**Height Variances:** Height Variances may be issued for all types of booths. However, in a Linear Booth, the back side of any structure over 8ft (2.44m) must be free of trademarks, graphics and/or logos.

**Environmental Responsibility:** Exhibitions and events, by their very nature, create waste. Properly managed, exhibitions and events can recycle excess materials and supplies in useful and meaningful ways, and they can do so using methods that result in minimized impact on the environment. Exhibits should utilize recycled, renewable and energy efficient materials whenever possible.



**12700 Park Central Drive, Suite 308**  
**Dallas, TX 75251-1500**  
**USA**

**[www.iaee.com](http://www.iaee.com)**